

High precision
planetary gearboxes

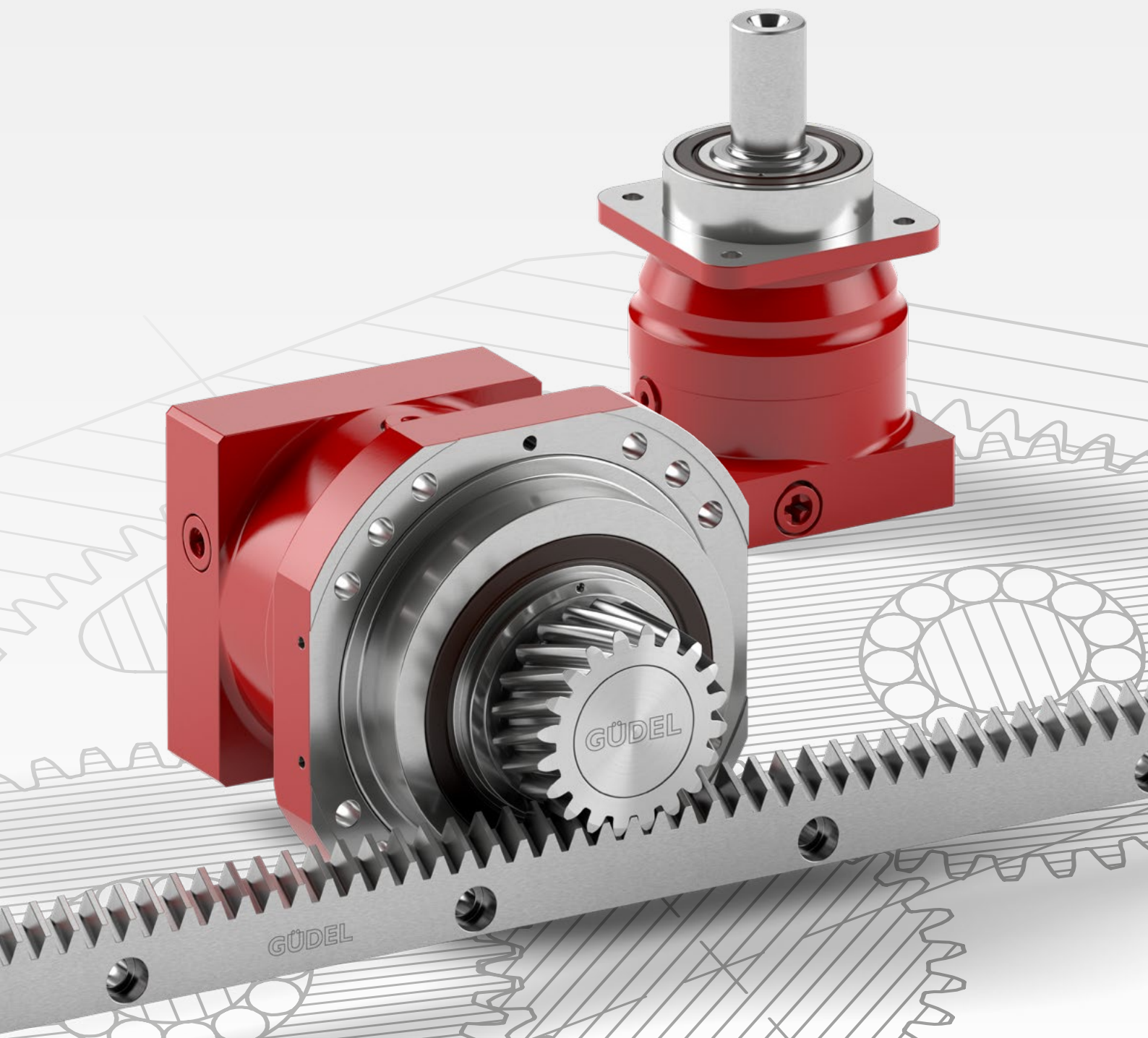

High precision planetary gearboxes

GÜDEL



GÜDEL

10088

10088

Content

High precision planetary gearboxes

Insights	Products meet industry.....	6
Product overview	Take six – The product at a glance.....	8
GAdjustment	NGHP – An innovative system solution.....	10
Performance	Six types to cover a wide range of application requirements.....	12
Preselection	Make your decision – Range, speed & torque.....	14
Inputs	Great adaptability – Standard & optional inputs.....	16
Outputs	Unlimited flexibility – Standard and optional outputs.....	18
Positioning	Reliability – Regardless of the mounting position.....	20
Function packages	Your ideal drive train – Gearbox, rack & pinion.....	22
Configuration	Find your right size – Performance & configuration.....	24
Configuration	Find your right configuration – Available inputs and outputs.....	26

Technical data sheets

Type NRH.....	30
Type NRHP.....	42
Type NGHP.....	54
Type NR.....	66
Type SR.....	78
Type PR.....	98

Your ideal drive train

Pinion – helical teeth.....	120
Rack – helical teeth.....	121

Technical information

Order reference	Generate the code of your planetary gearbox.....	128
Order reference	Choose your appropriate motor interface.....	130
Flowcharts	Calculate your planetary gearbox.....	132
Flowcharts	Calculate your ideal drive train.....	136

Güdel worldwide

Contacts.....	140
---------------	-----

Products meet industry

Güdel offers a wide range of products and solutions to key industries. Our global sales and service network provides our customers with first-class consultation and support services around the globe, for the entire product life cycle.

Güdel gearboxes are available in four different precision grades. Combined with the appropriate rack, available in three quality classes Q6, Q7 and Q9, an ideal drivetrain can be configured according to the application requirements.

Güdel in every axis

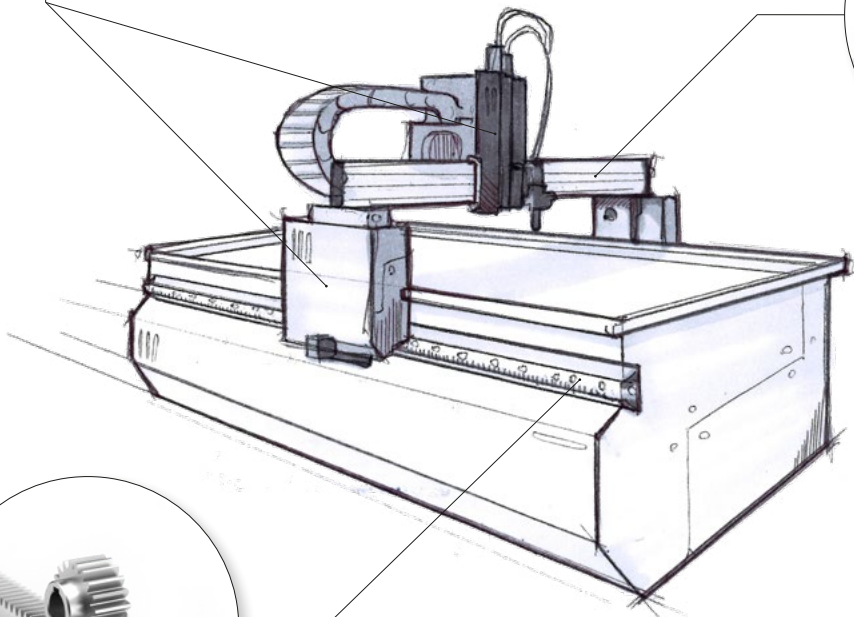
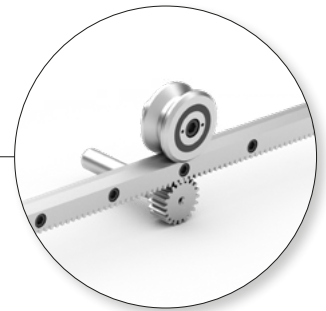

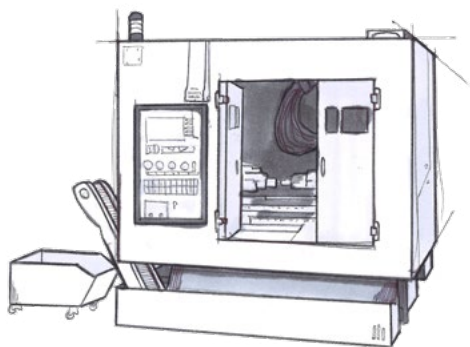

Machine tools

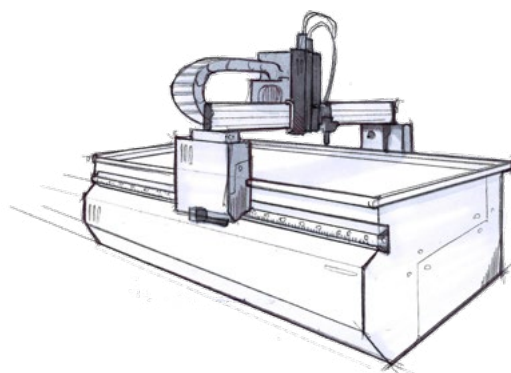

Cutting machines
laser, plasma, water, glass

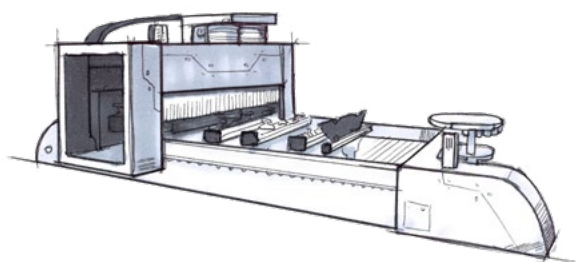

Wood, plastic and composite
processing machines

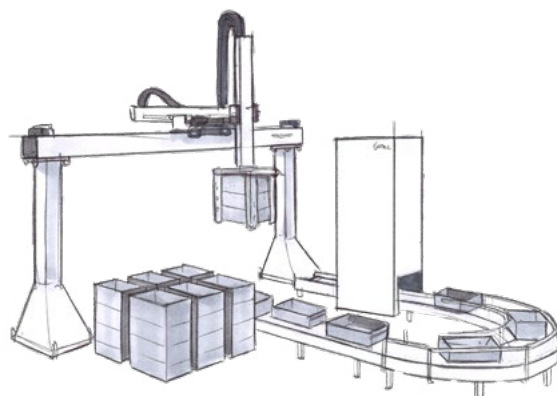

Robotics, automation and
handling technology

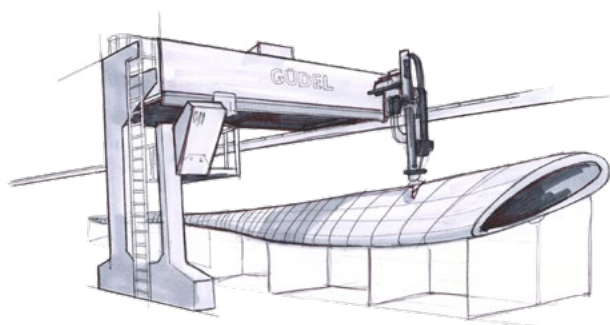

Wind and energy

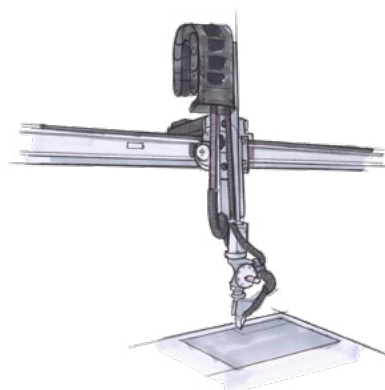

Aerospace and defense technology

Take six – The product at a glance

Due to their outstanding mechanical properties, planetary gearboxes are found in a wide spectrum of industrial applications. Güdel high-precision planetary gearboxes provide the ideal solution for demanding operations. Performance details and drawings are found on the technical datasheets.

Precision – With regard to angular backlash, our extensive experience in the design and the manufacture of high-performance gearboxes gives us the ability to provide all products in four different precision grades: I, 3, 5 and I2 arcmin

Sizes – Our portfolio includes five sizes: 080, 100, 140, 180 and 240. Additional sizes are available upon request.

Ratios – A wide range of ratios can be selected – starting from 3 up to 1000. Depending on the ratio the gearbox will either have one, two or three stages.

NRH, NRHP and NGHP

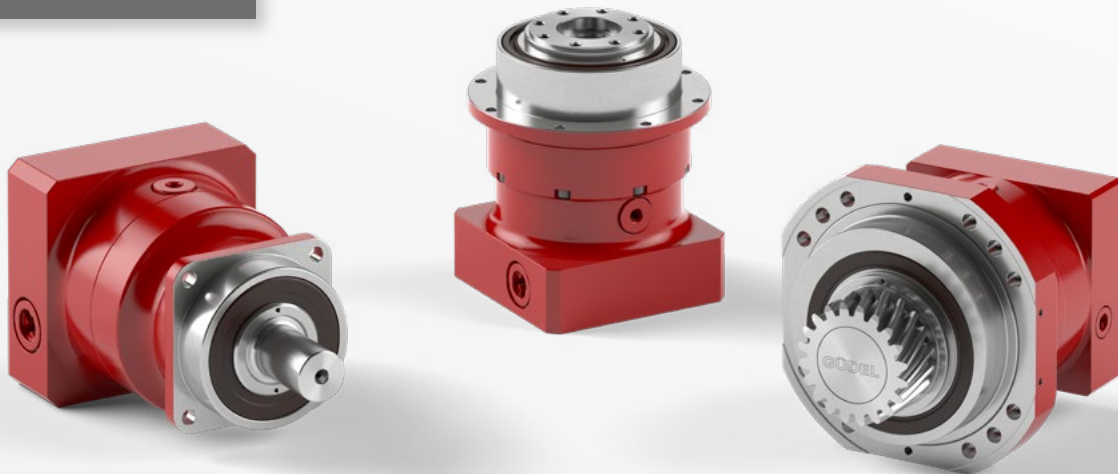

NRH type – For high precision

The NRH planetary gearbox with optimized helical gearset teeth was developed for highly demanding applications. These gearboxes are perfect for applications ranging from basic machine design to printing, packaging, and robotics. Designed for high speed and acceleration – and for perfect production flows.

NRHP type – For high stiffness

The NRHP flange mount planetary gearboxes offer superior torsional stiffness and tilt rigidity, perfectly suited for high precision processes and production flows.

NGHP type – For smart adjustment

The planetary gearbox NGHP is built on the proven technology of the Güdel NRHP series planetary gearboxes. The unique interface, together with the web application GAdjuster guarantees a precise, simple, and error free gear mesh adjustment for rack and pinion drive train.

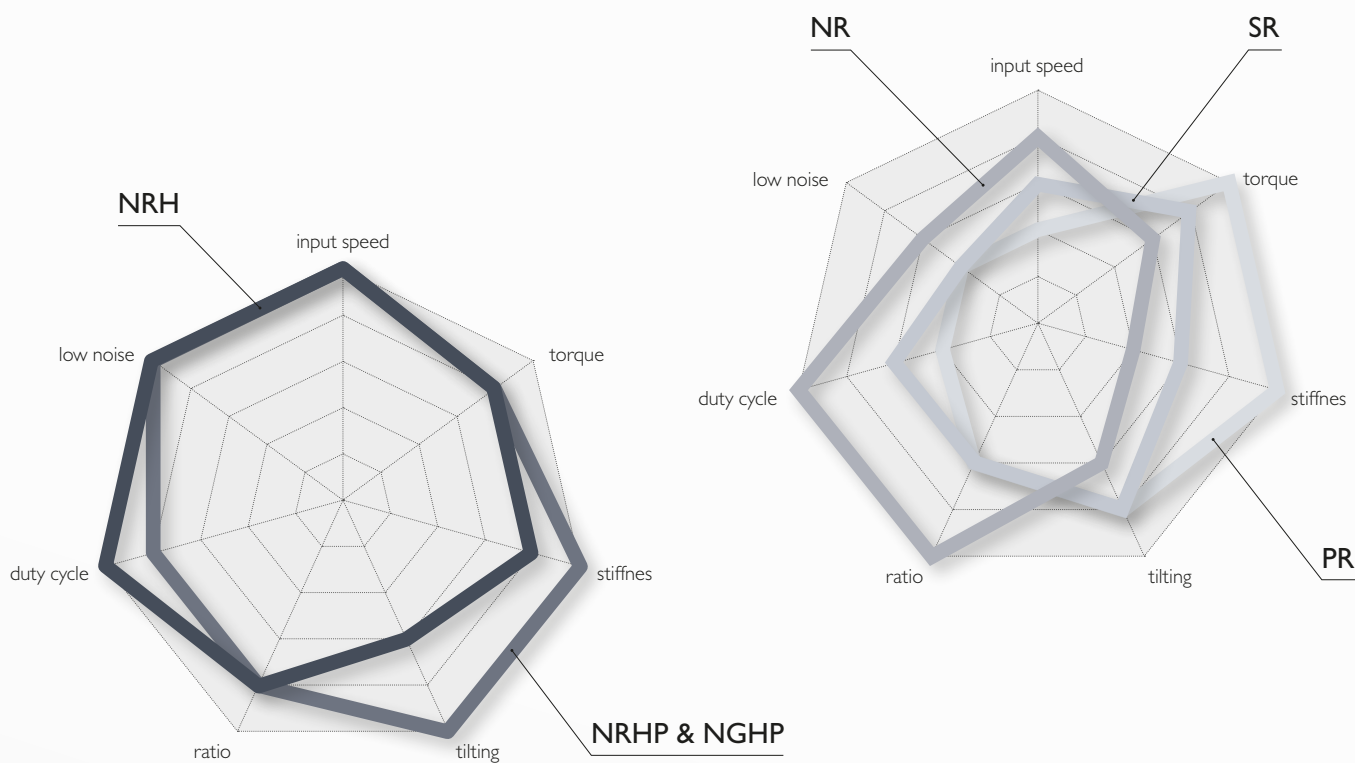

NR, SR and PR

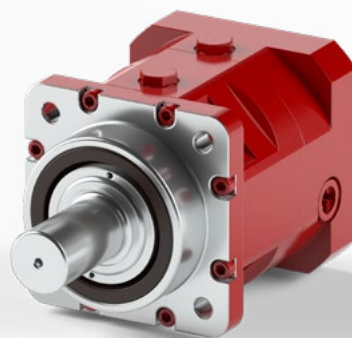

NR type – For high flexibility

For use in most applications that require torque, precision and high speed operation in continuous S1 and discontinuous S5 duty cycles.

SR type – For high torque

Without an increase in size, the SR range provides 33% more torque than the NR range and is used in discontinuous duty cycles of S5 and more.

PR type – For hyper torque

Without an increase in size, the PR range operates with 100% more torque than the NR and is used in discontinuous duty cycles of up to S5.

NGHP – An innovative system solution

Planetary gearbox with integrated eccentric output flange which provides precise gear mesh adjustment for the rack and pinion drive train.

The performance of a rack and pinion drive system is greatly influenced by how precisely the gear mesh between rack and pinion are set, as well as by the precision of the individual components. This gear mesh is typically set via the radial relationship of the pinion to the rack. To achieve low backlash, the pinion engages with the rack through a linear movement of the gearbox.

While seemingly easy in theory, this proves difficult in practice and can only be achieved with great effort, trained personnel, and suitable measurement equipment. Costly repetitive measurements and perhaps even specific equipment may be required for the customer's machine structure.

Güdel has now developed an innovative system, which in a very simple way, resolves the setting of the gear mesh between rack and pinion, while setting new standards when it comes to precision, performance, cost-effectiveness, and ease of maintenance.

At the heart of this innovative GAdjustment system is a low backlash planetary gearbox with an internal eccentric flange that rotates about the pinion. Once the gearbox is mounted into the machine structure by attaching the flange the pinion is engaged with the rack by rotating the gearbox housing. Fully supporting the radial mounting surface of the output flange provides maximum stiffness, resulting in longer gearbox bearing life. A benefit of this method of adjustment is that the ratio between rotation and pinion linear motion allows finer adjustment increments. This results in high precision and accuracy of the gear mesh between rack and pinion. This eccentric motion also enables the pinion to be completely disengaged from the rack when the planetary gearbox is rotated 180 degrees into the mounting position. In this way, the drive system can be quickly decoupled to allow manual movement for maintenance activity.

Key features of this system



Maximum stiffness due to form fit support of the output bearing and the CP (compact pinion) solution



Precise and repeatable adjustment process for setting gear mesh



Compact functional unit with integral mounting and positioning system built into one component



Assembly and disassembly with standard tools



Set-up guidance through the easy-to-use web application GAdjuster



Simple and cost-effective interface to the customer's machine structure



Quick disengagement of the pinion from the rack for maintenance work



Optimal force transmission into the customer-side machine structure

Compact package with high stiffness

The planetary gearbox NGHP is built on the proven technology of the Güdel NRHP Series planetary gearboxes. The addition of the unique adjustable flange mounting methodology provides both ease of adjustment and superior torsional stiffness and rigidity.

All-new interface

The all-new designed interface of the NGHP gearbox with the eccentric output flange guarantees optimal performance due to its form fit support. Furthermore, the new interface simplifies the customer structure and thus helps to reduce costs.

Integrated output pinion CP

The all-new designed interface of the NGHP gearbox with the eccentric output flange guarantees optimal performance due to its form fit support. Furthermore, the new interface simplifies the customer structure and thus helps to reduce costs.

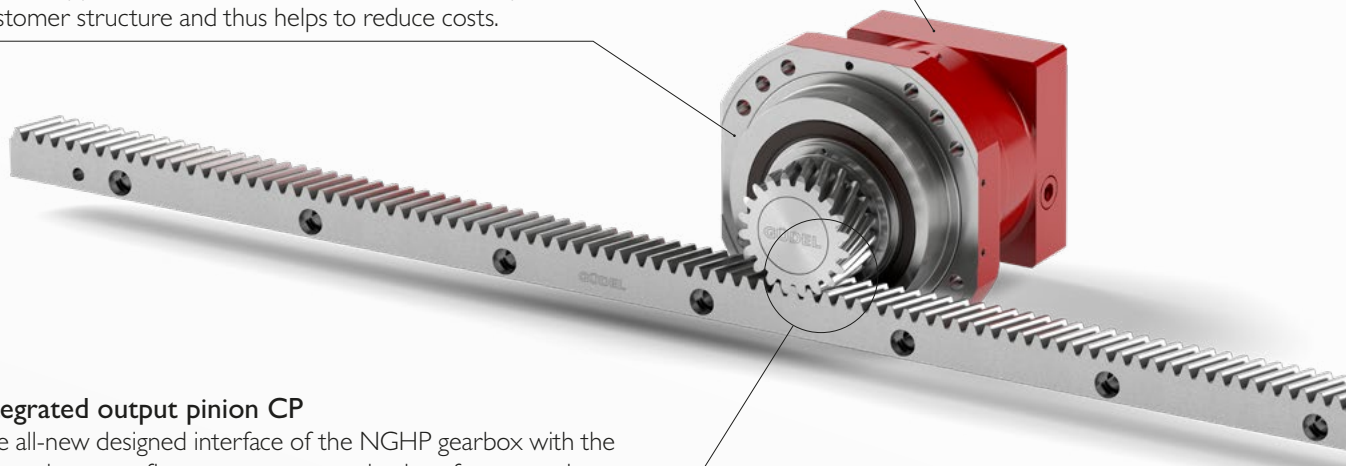

GAdjuster web application

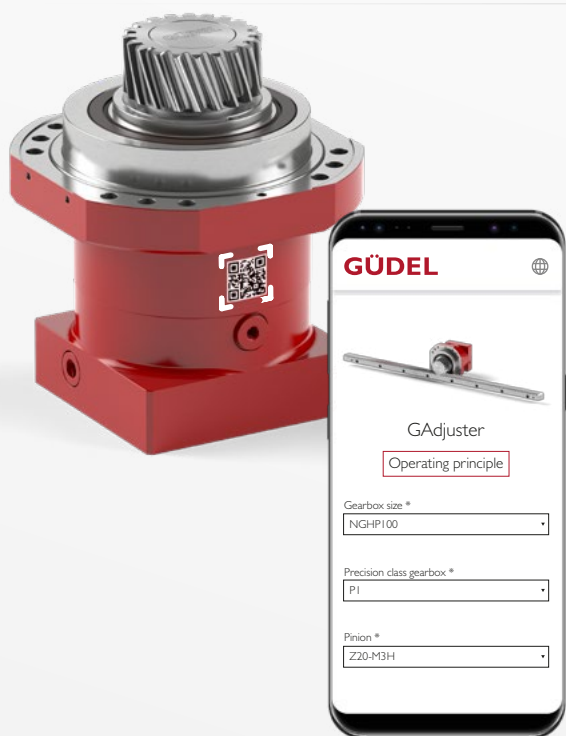

The GAdjuster supports you with a guided process for adjusting the gear mesh between rack and pinion. More than 20 years of experience in drive train technology allow us to give you a setting recommendation based on your configuration. Scan the QR code on the gearbox and set the recommended linear backlash by using step by step the easy-to-follow web application.

- Guided adjustment process
- Recommended linear backlash settings based on 20 years experience in drive train technology
- Detection of gearbox configuration
- Platform independent
- Quick link to the operating principle
- Related links to operating manual and catalog

Six types to cover a wide range of application requirements

Our six types, NRH, NRHP, NGHP, NR, SR, and PR provide you with a broad performance spectrum. Input speeds range up to 6000RPM, and output torques up to 5600 Nm.

The NRH, NRHP and NGHP types provide an excellent combination of performance characteristics: torque, speed, precision, low noise, and high duty cycle. The NRHP and NGHP are suitable when high stiffness and tilting rigidity is required.

The NR type offers flexibility and modularity, with the largest range of sizes, stages, and ratios.

The SR and PR ranges focus specifically on high torque or even hyper torque which needs to be performed in a limited space.

For each gearbox size, the three ranges of the NR, SR, and PR family have the same body. Minor variations at the output adapt the product to the higher torque capacity.

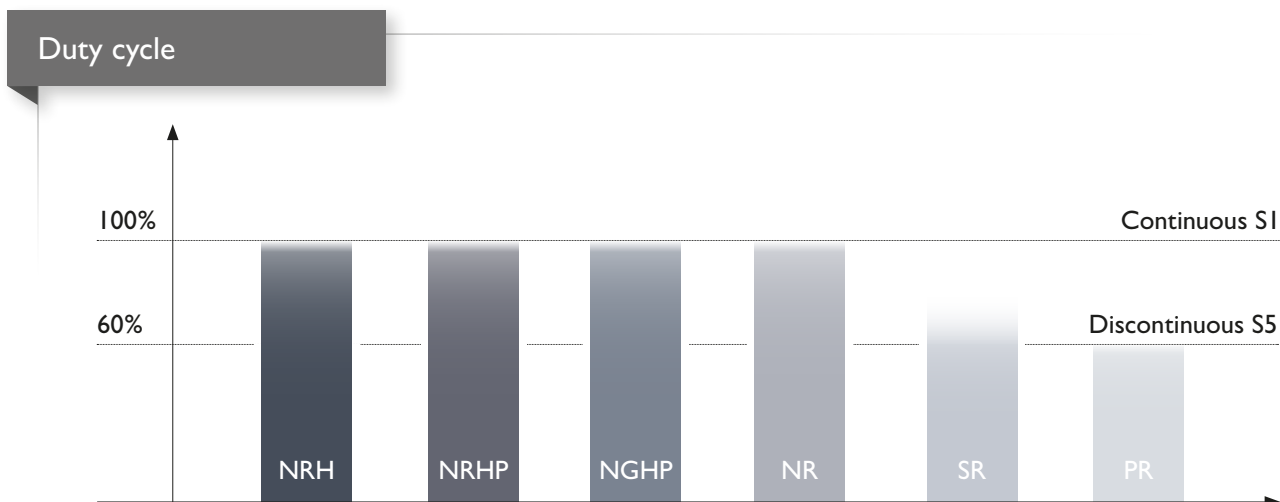
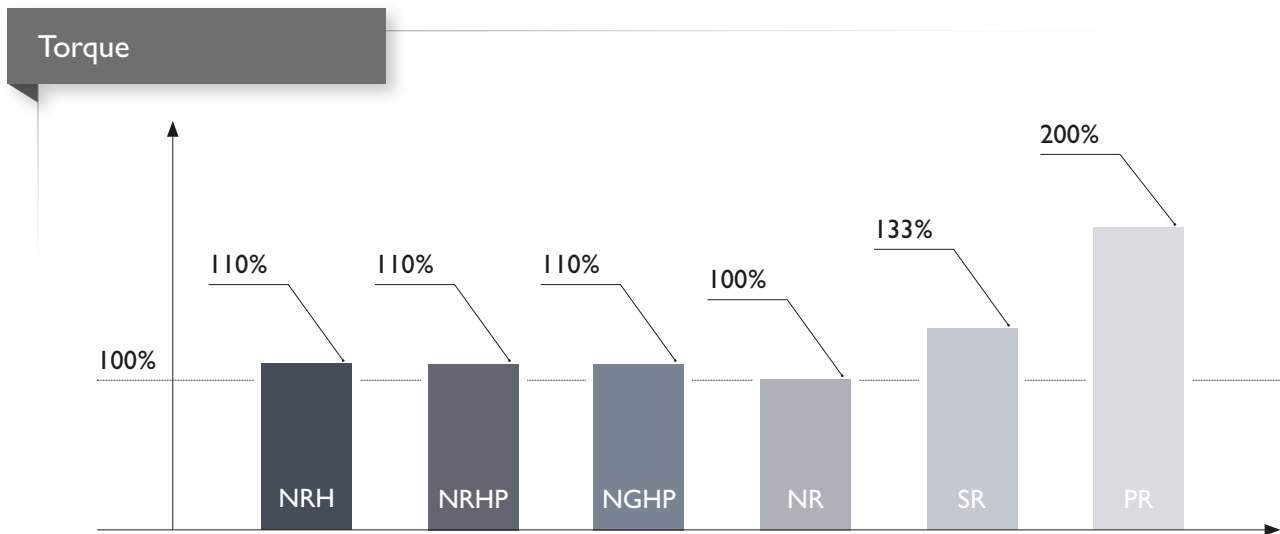

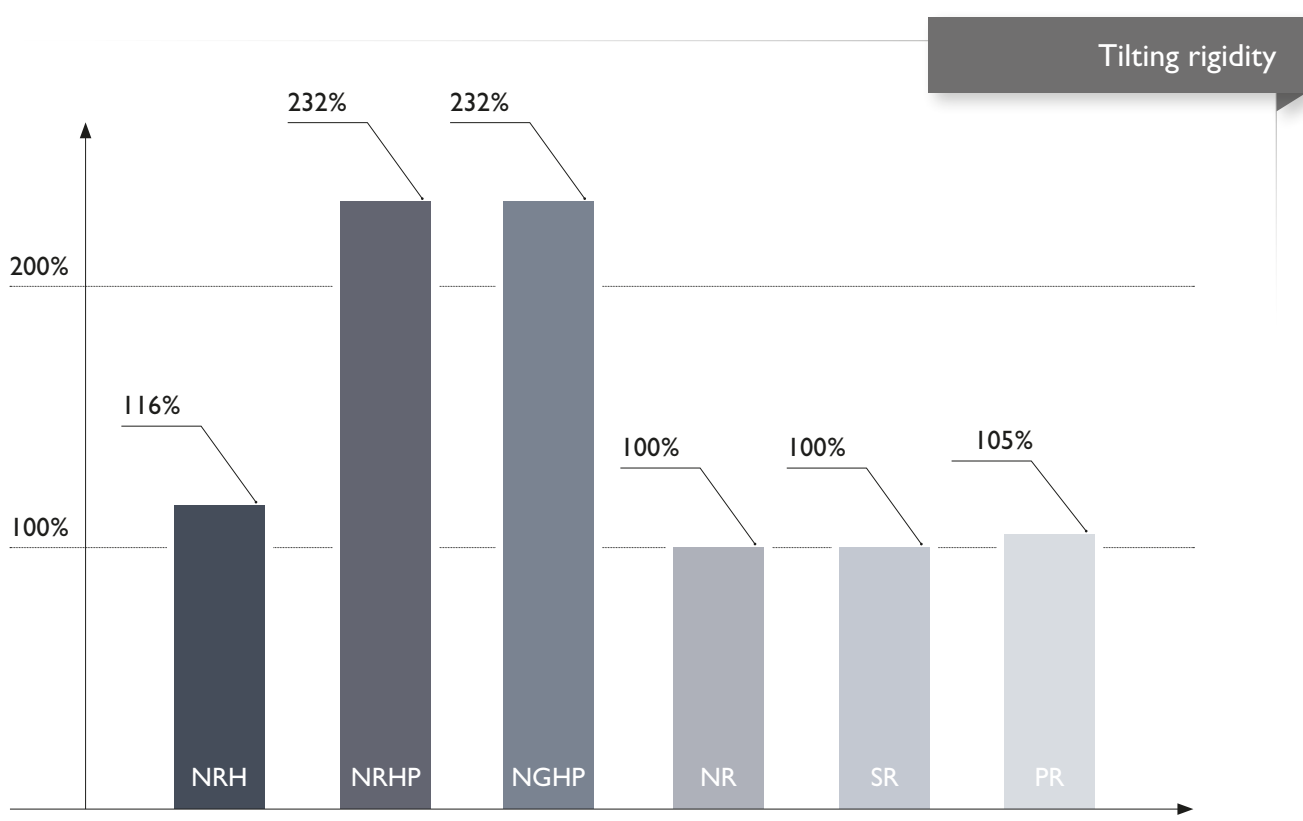
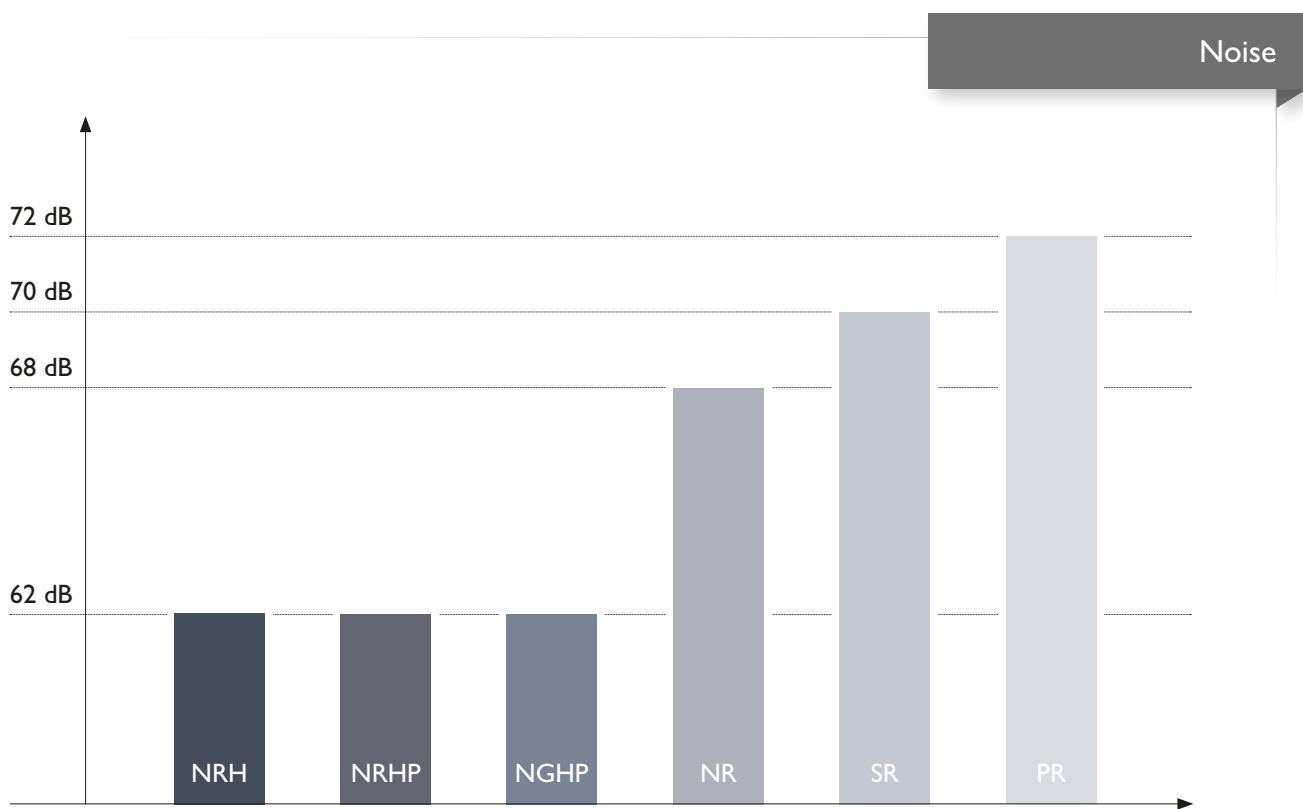

Make your decision – Range, speed & torque

Use the technical summaries to make your preselection from the five main gearbox types. Base your gearbox selection on the most important requirements for your particular application: torque, gearbox size, duty cycle, angular backlash, ratio, and speed.

Select NRH, NRHP and NGHP for high input speeds, or the NR type when modularity and a wide range of sizes, stages, and ratios is most important.

Choose the SR or PR type if your application requires high or hyper torque. The following graphs are based on a ratio of 12 in a discontinuous S5 duty cycle. Compare the maximum input speed n_{1max} and acceleration torque T_{2B} for the five types.

Types		NRH	NRHP	NGHP	NR	SR	PR
Torque		110%	110%	110%	100%	around 133%	around 200%
Duty cycle	S5	60%	60%	60%	60%	60%	60%
	SI	100%	100%	100%	100%	–	–
Angular backlash	Precision	P 1 P 3 P 5	P 1 P 3 P 5	P 1 P 3 P 5	P 1 P 3 P 5 P 12	P 1 P 3 P 5 P 12	P 1 P 3 P 5 P 12
	arcmin	≤ 1 ≤ 3 ≤ 5	≤ 1 ≤ 3 ≤ 5	≤ 1 ≤ 3 ≤ 5	≤ 1 ≤ 3 ≤ 5 ≤ 12	≤ 1 ≤ 3 ≤ 5 ≤ 12	≤ 1 ≤ 3 ≤ 5 ≤ 12
Ratio *	1-stage	3, 4, 5, 7, 10	3, 4, 5, 7, 10	3, 4, 5, 7, 10	3, 4, 5, 7, 10	4	3
	2-stage	12, 16, 20, 25, 30, 35, 40, 50, 70, 100	12, 16, 20, 25, 30, 35, 40, 50, 70, 100	12, 16, 20, 25, 30, 35, 40, 50, 70, 100	12, 16, 20, 25, 30, 35, 40, 50, 70, 100	12, 16, 20, 28, 40	9, 12, 15, 21, 30
	3-stage	–	–	–	36, 45, 60, 75, 90, 105, 120, 150, 210, 300	60, 80, 100, 112, 120, 140, 160, 200, 280, 400	36, 45, 60, 75, 90, 105, 120, 150, 210, 300

* Other ratios are available on request.

Input speed

n_{1max} [rpm]

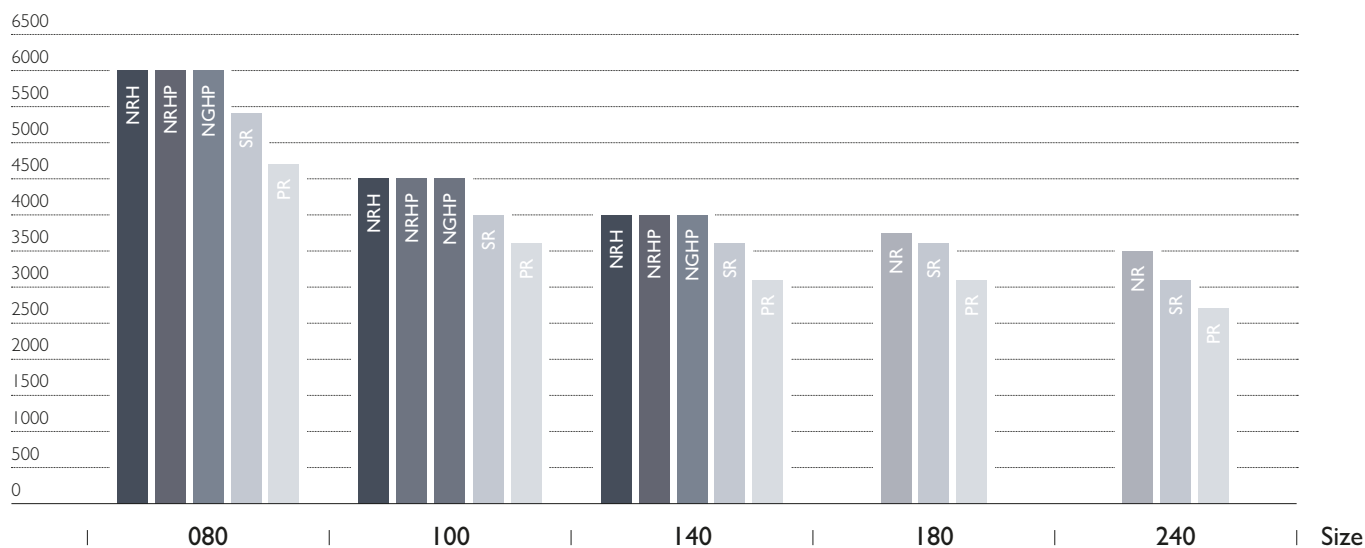

Output torque

T_{2B} [Nm]

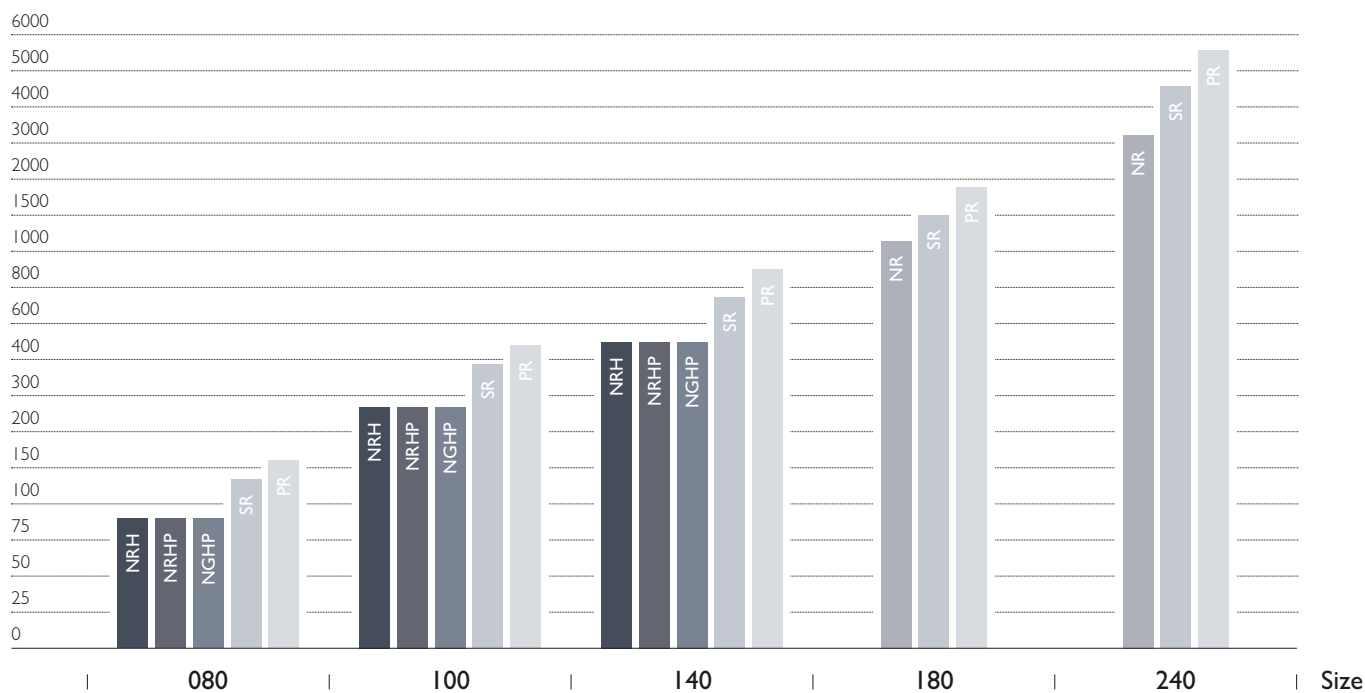

Great adaptability – Standard & optional inputs

Due to our modular system, all common servo motors can be easily mounted on our planetary gearboxes. Optional inputs such as primary shaft can be provided on request.

We have a standard flange solution for the most commonly used servo motors. Depending on the range of the gearbox, we offer a total of three standard input versions. Your selection of an input will depend on the geometric dimensions of the motor.

Standard inputs

Small motor

Medium motor

Long motor

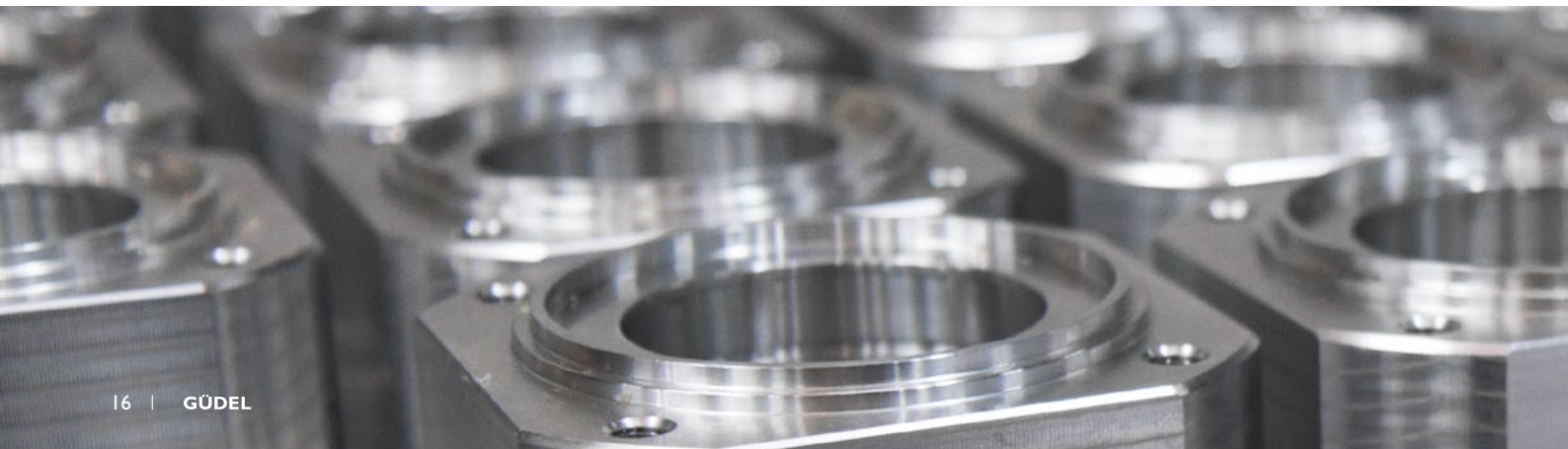
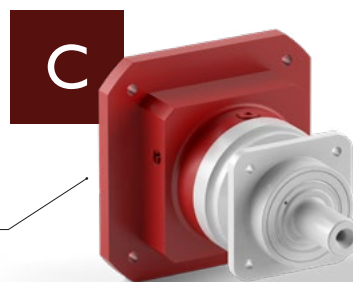
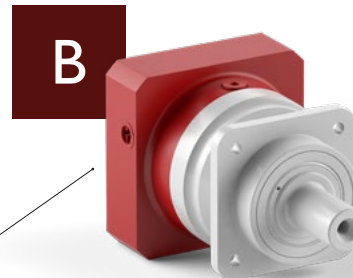
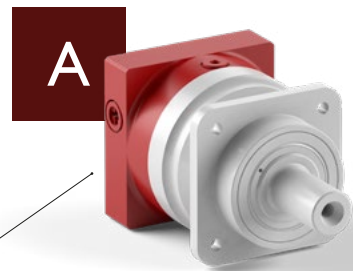

Standard inputs

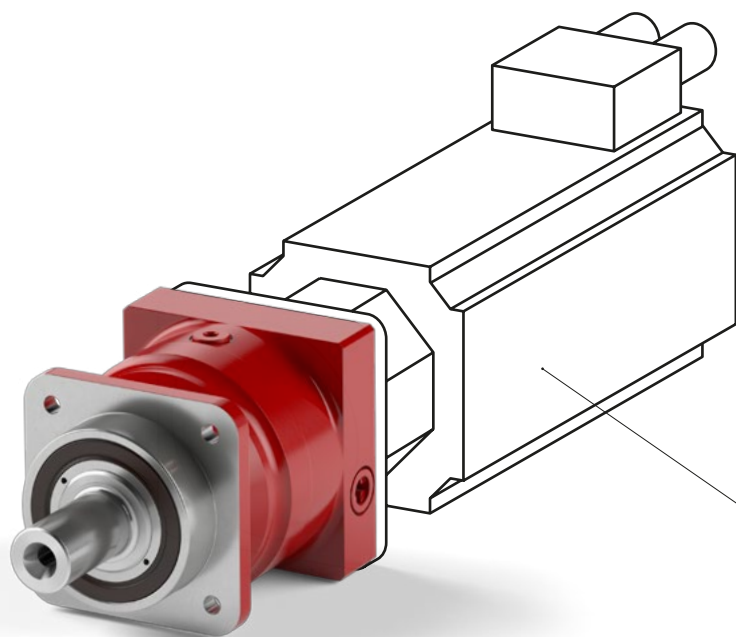

AM – Motor adaptability

Optional inputs

For special applications, in which the motor cannot be directly mounted on the gearbox, it is possible to fit the gearbox with an optional input shaft.

Example AL

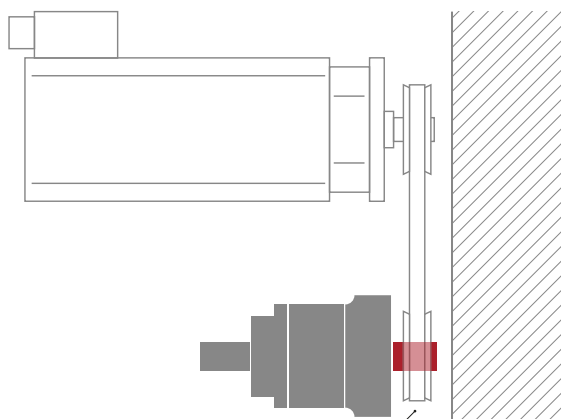

AL – Smooth primary shaft

Example AC

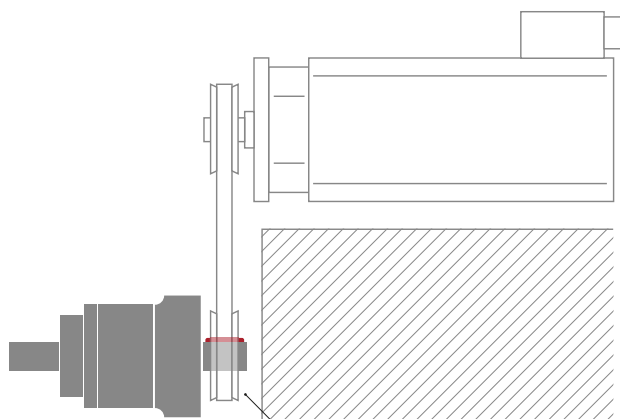

AC – Keyway primary shaft

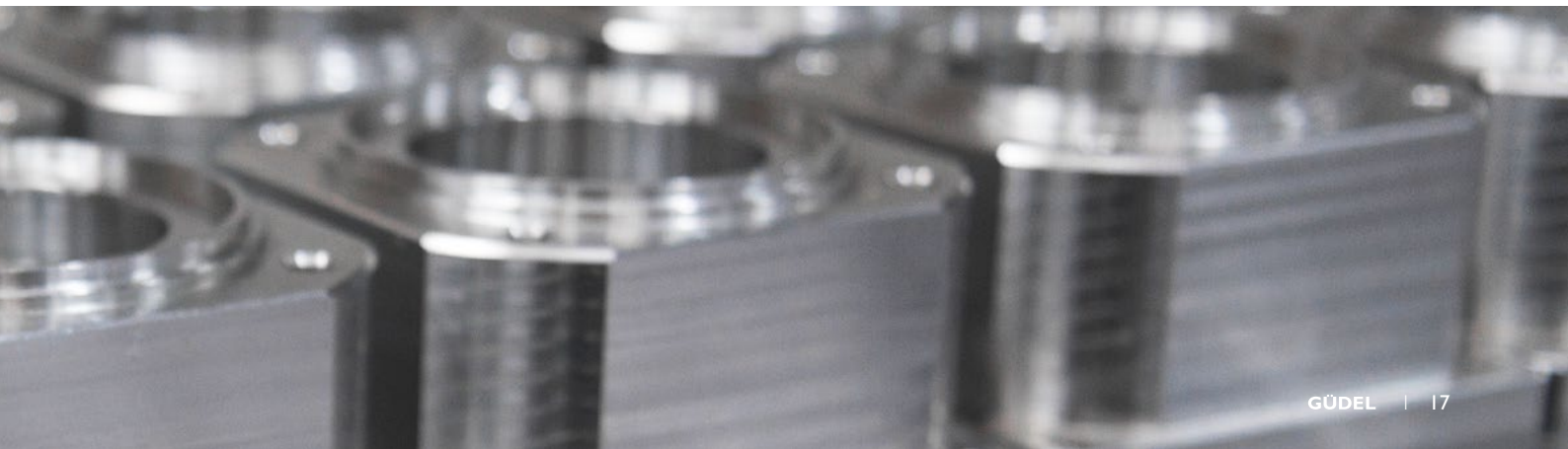

Unlimited flexibility – Standard and optional outputs

To meet your requirements, our planetary gearboxes offers six output options to cover the broadest possible range of applications.

Three standard outputs are available in stock, with three additional outputs available upon request. Please don't hesitate to contact us if your application requires a configuration not shown here.

Standard outputs

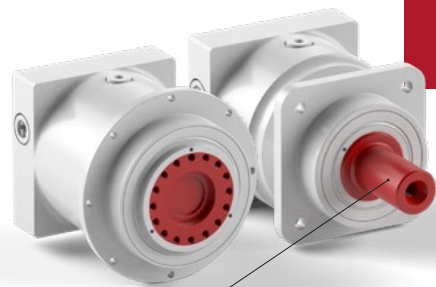

Smooth output shaft and flange

The reference standard output with dimensions according to market standards.

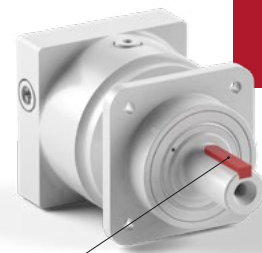

Keyway output shaft

A keyway according to DIN 6885 can be added to the smooth shaft.

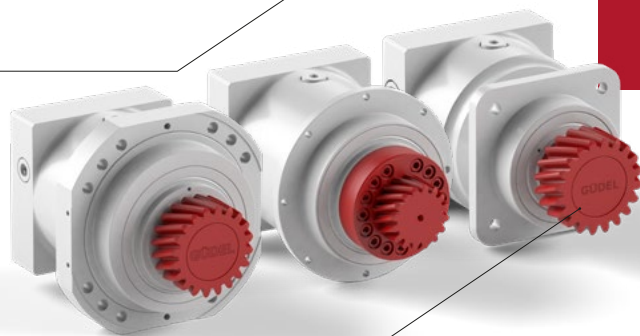

Integrated output pinion

The integrated output pinion is a unique solution – combining rack, pinion and gearbox. This function package creates an ideal drive train.



Optional outputs

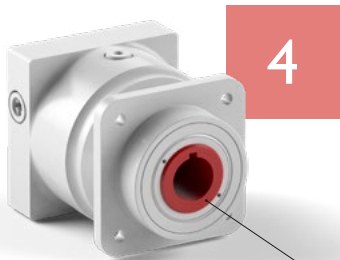

Customized output shaft
Please contact us, if the standard output shafts do not meet your specification.



Hollow keyway output
On request we can provide you with a hollow keyway output. Please find the details on the technical information pages.

Splined output shaft
Splined output shafts are available on request. Please specify dimensions as well as type of spline (standard) and tolerances required.

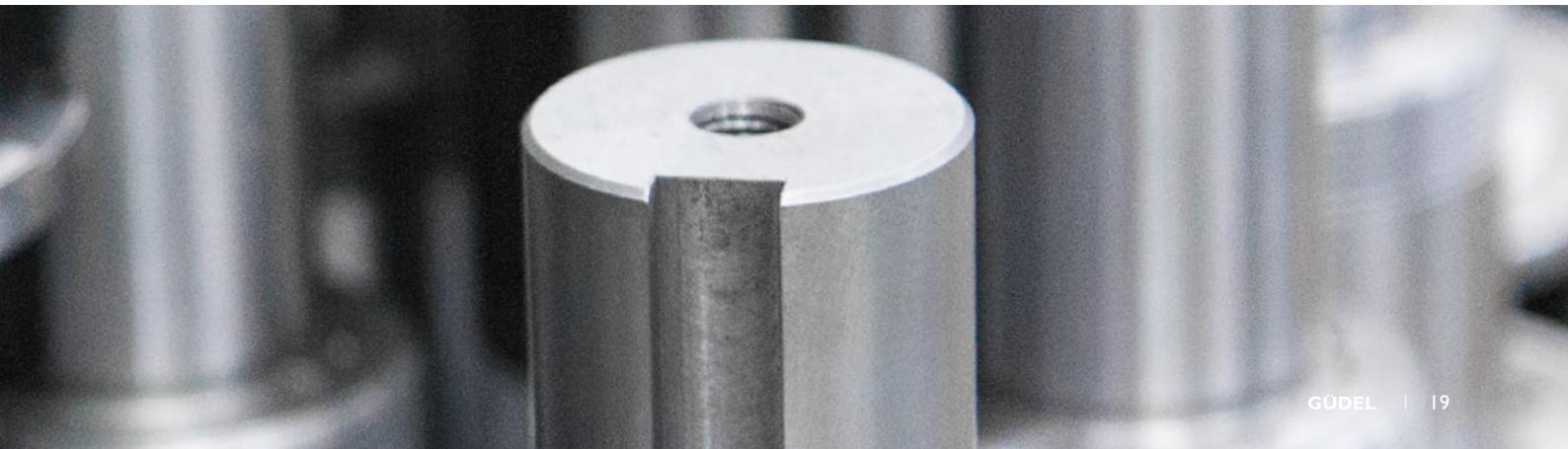

Reliability – Regardless of the mounting position

Our high-performance planetary gearboxes can be used in any mounting orientation. Whether your application requires a horizontal output (HI), vertical with upright facing output (VI), or vertical with downward-facing output (V2) – the universal TP configuration covers any orientation.

For specific applications, including continuous operation SI together with high input speed, we recommend the use of an additional air-vent plug (breather). This air-vent plug can be installed at any time – even as a retrofit on installed gearboxes.

In order to optimize gearbox performance, we recommend specifying the actual mounting position VI, V2 or HI, especially for ratios requiring a 3-stage gearbox.

Mounting positions

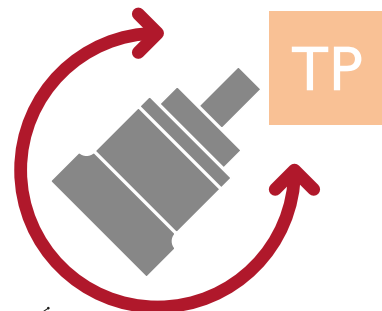

All positions



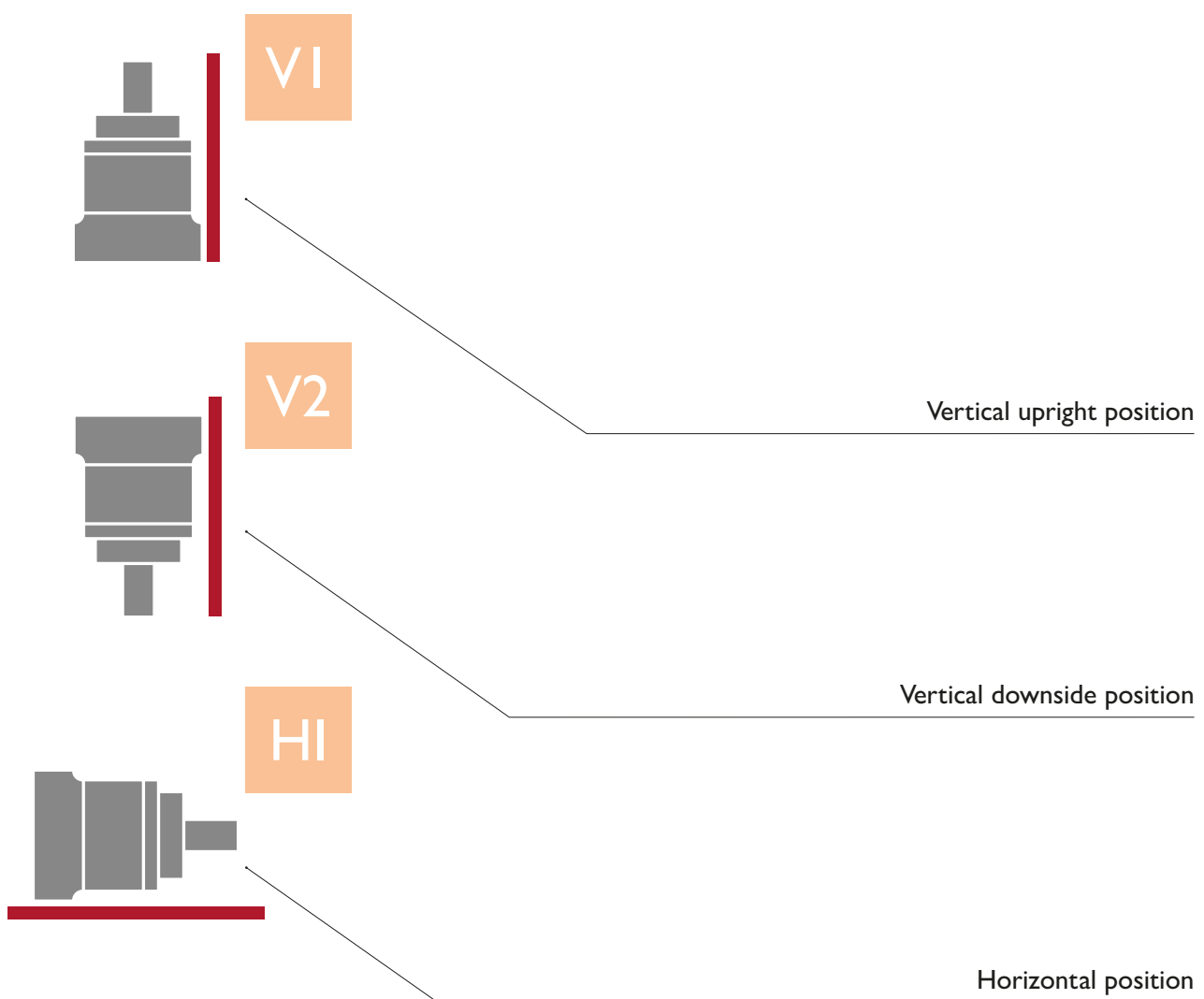

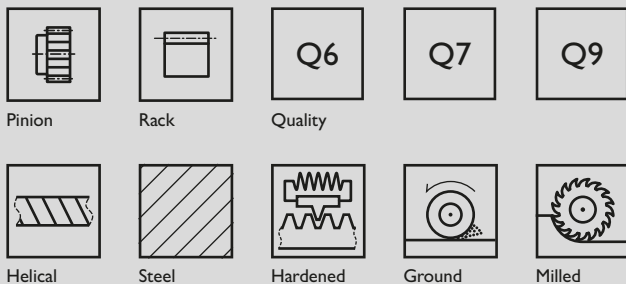

	High-end applications		Standard applications		Basic applications	
Rack	Q6		Q7		Q9	
Gearbox	P1	P3	P3	P5	P5	P12
Precision	High				Standard	
Feed force	High		Medium		Elevated	

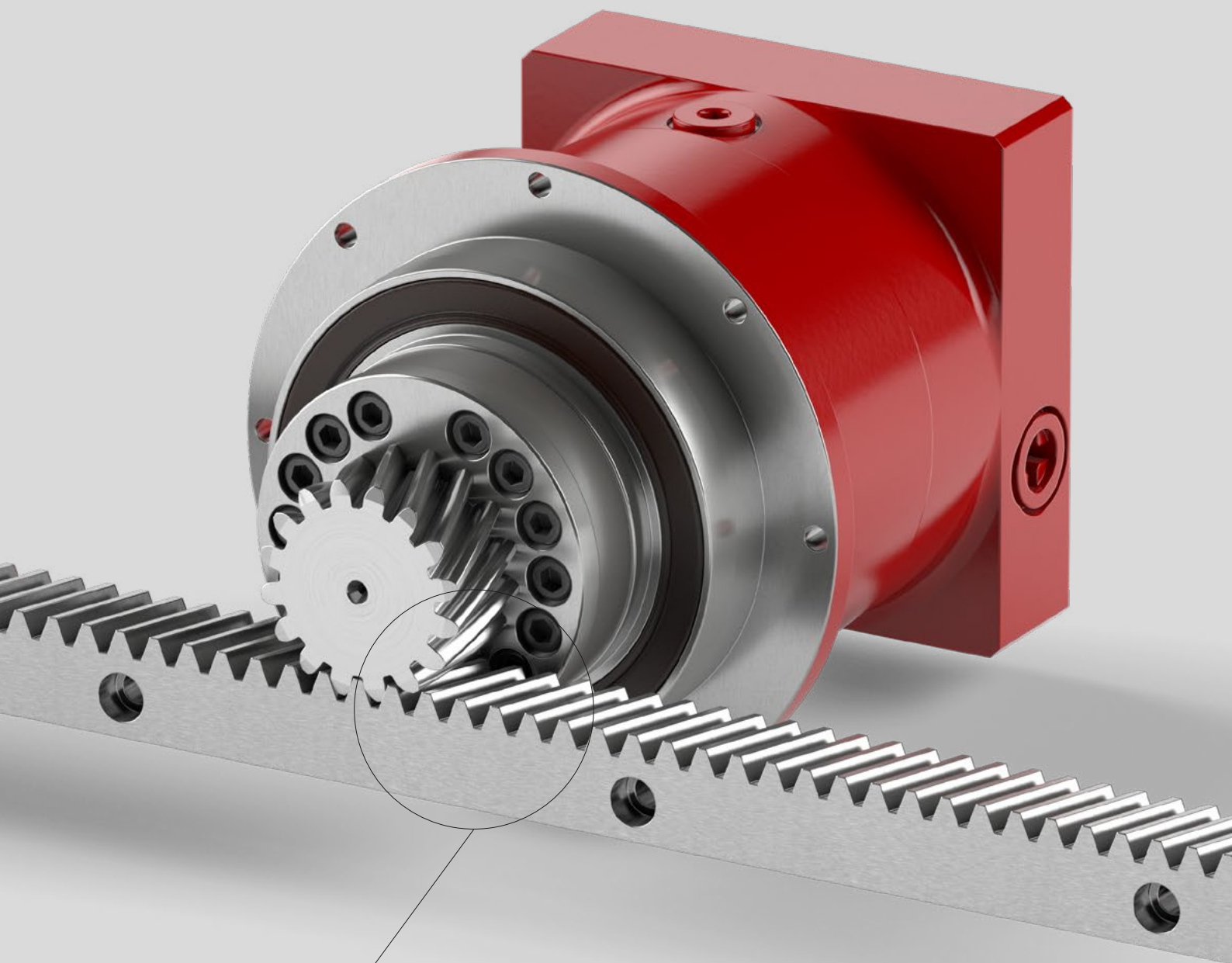

Quality in accordance with
DIN 3962 Q6 hardened
and ground

Find your right size – Performance & configuration

High performance

High stiffness

Smart adjustment

Size	NRH			NRHP			NGHP		
	T _{2B} [Nm]	Stage	Page	T _{2B} [Nm]	Stage	Page	T _{2B} [Nm]	Stage	Page
080	≤ 110	1	30–31	≤ 110	1	42–43	≤ 110	1	54–55
		2	32–33		2	44–45		2	56–57
100	≤ 350	1	34–35	≤ 350	1	46–47	≤ 350	1	58–59
		2	36–37		2	48–49		2	60–61
140	≤ 650	1	38–39	≤ 650	1	50–51	≤ 650	1	62–63
		2	40–41		2	52–53		2	64–65
180	–	–	–	–	–	–	–	–	–
240	–	–	–	–	–	–	–	–	–

High modularity

High torque

Hyper torque

NR			SR			PR			Size
T _{2B} [Nm]	Stage	Page	T _{2B} [Nm]	Stage	Page	T _{2B} [Nm]	Stage	Page	
–			≤ 150	1	78–79	≤ 160	1	98–99	080
				2			3		
				3	80–81				
–			≤ 404	1	82–83	≤ 556	1	102–103	100
				2			3		
				3	84–85				
–			≤ 750	1	86–87	≤ 900	1	106–107	140
				2			3		
				3	88–89				
≤ 1150	1	66–67	≤ 1500	1	90–91	≤ 1925	1	110–111	180
	2	68–69		2			3		
	3	70–71		3	92–93				
≤ 3800	1	72–73	≤ 4800	1	94–95	≤ 5600	1	114–115	240
	2	74–75		2			3		
	3	76–77		3	96–97				

Find your right configuration – Available inputs and outputs

Standard inputs

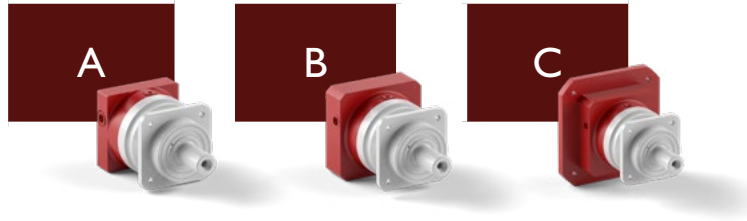

Size	Type	Small	Medium	Long
080	NRH	•	•	•
	NRHP	•	•	•
	NGHP	•	•	•
	SR	•	•	*
	PR	•	•	*
100	NRH	•	•	•
	NRHP	•	•	•
	NGHP	•	•	•
	SR	•	•	*
	PR	•	•	*
140	NRH	•	•	•
	NRHP	•	•	•
	NGHP	•	•	•
	SR	•	•	•
	PR	•	•	•
180	NR	•	•	•
	SR	•	•	•
	PR	•	•	•
240	NR	•	•	*
	SR	•	•	*
	PR	•	•	*

• Available / * We provide additional flanges for bigger motors on request.

Standard outputs

Optional outputs

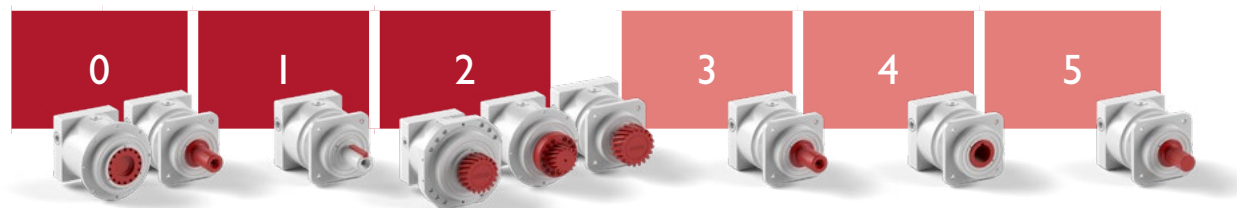

Flange	Smooth	Keyway	Pinion
-	•	•	•
•	-	-	•
-	-	-	•
-	•	•	•
-	•	•	•
-	•	•	•
•	-	-	•
•	-	-	•
-	•	•	•
-	•	•	•
-	•	•	•
•	-	-	•
•	-	-	•
-	•	•	•
-	•	•	•
-	•	•	•
-	•	•	•
-	•	•	•
-	•	•	•
-	•	•	•
-	•	•	•

Custom	Hollow	Splined
•	•	•
-	-	-
-	-	-
•	•	•
•	•	•
•	•	•
•	•	•
-	-	-
-	-	-
•	•	•
•	•	•
•	•	•
•	•	•
-	-	-
-	-	-
•	•	•
•	•	•
•	•	•
•	•	•
•	•	•
•	•	•
•	•	•
•	•	•

Type	Size
NRH	080
NRHP	
NGHP	
SR	
PR	100
NRH	
NRHP	
NGHP	
SR	140
PR	
NRH	
NRHP	
NGHP	180
SR	
PR	
NR	
NRH	240
NRHP	
NGHP	
SR	
PR	

• Available / * We provide additional flanges for bigger motors on request.



GÜDEL

TECH

GÜDEL

Technical data sheets

GÜDEL

Input

A	for motor shaft	$L \leq 50$	$\varnothing d \leq 19$	result in LA
B	for motor shaft	$50 < L \leq 55$	$\varnothing d \leq 24$	result in LB
C	for motor shaft	$55 < L \leq 60$	$\varnothing d \leq 24$	result in LC

		I-stage	2-stage
LA	[mm]	117.1	154.1
LB	[mm]	125.6	162.1
LC	[mm]	130.1	167.1

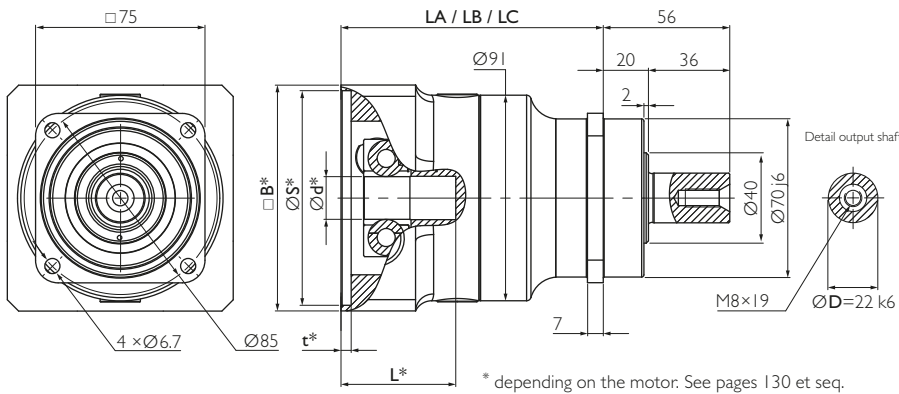

Example NRH 080 A0, I-stage

Output

Standard

Optional

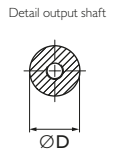
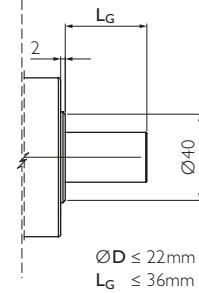

$\varnothing D \leq 22\text{mm}$
 $L_G \leq 36\text{mm}$

Option 3 on request. Adjustments can reduce capacity.

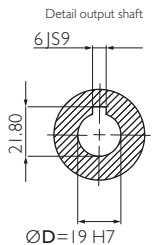
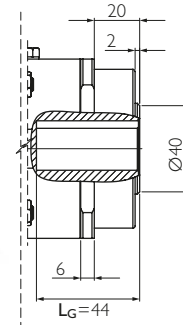

$\varnothing D = 19\text{ H7}$

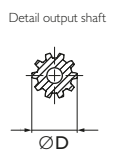
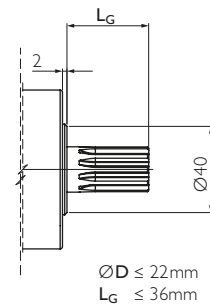
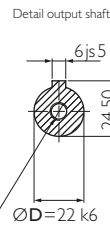
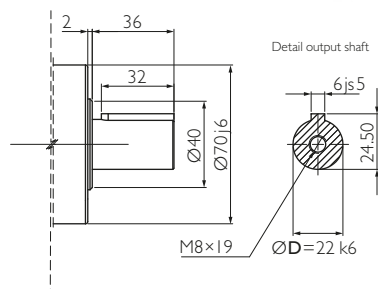

$\varnothing D \leq 22\text{mm}$
 $L_G \leq 36\text{mm}$

Option 5 on request. Adjustments can reduce capacity.

Your ideal drive train

Function Package with gearbox, rack and pinion from Güdel

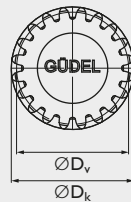
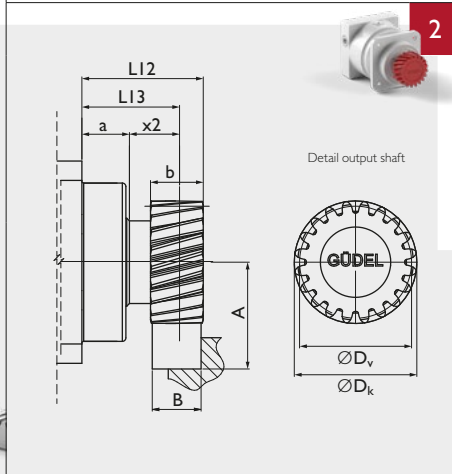
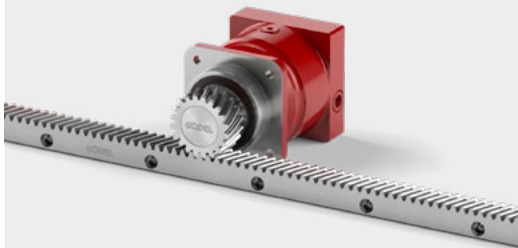

Material 16MnCr5 DIN 1.7131
Teeth pressure angle $\alpha = 20^\circ$, helical teeth left, 19°31'42" hardened (58⁺⁴ HRC), ground, crowned
Quality 6f24 DIN 3962 / 63 / 67

Pinion

	m_n	P_t	z	A	b	D_k	D_0	D_v	L12	L13	x2	a	M	
Pinion 1	[-]	2	6.66	20	43.221	25	46.44	42.441	42.441	52.5	40.0	20.0	20	0.3
Pinion 2	[-]	2.5	8.33	16	43.471	25	48.94	42.441	43.941	52.5	40.0	20.0	20	0.3

m_n : Normal module, P_t : Transverse pitch [mm], z : Number of teeth, D_0 : Pitch circle diameter for calculation, D_v : Pitch circle diameter for design, M: Weight [kg]

Available ratios	i		I-stage					
			3	4	5	7	10	
Nominal torque S5 ^{a)}	T _{2N}	[Nm]	65	75	76	76	60	
Acceleration torque S5 ^{b)}	T _{2B}	[Nm]	85	110	110	110	90	
Nominal input speed S5 ^{c)}	n _{1N}	[rpm]	2 900	2 900	2 900	3 100	3 100	
Maximum input speed S5	n _{1max}	[rpm]	5 000	6 000	6 000	6 000	6 000	
Nominal torque S1 ^{a)}	T _{2N}	[Nm]	–	50	50	50	35	
Acceleration torque S1 ^{b)}	T _{2B}	[Nm]	–	72	72	72	44	
Nominal input speed S1 ^{c)}	n _{1N}	[rpm]	–	2 600	2 600	2 800	2 800	
Maximum input speed S1	n _{1max}	[rpm]	–	2 900	2 900	3 100	3 100	
Emergency stop torque ^{d)}	T _{2not}	[Nm]	250	250	250	250	200	
Efficiency	η	[%]	97					
Lifetime	L _h	[h]	> 20 000					
Weight	M	[kg]	4					
Angular backlash	i _c	[arcmin]	Precision P 1 ≤ 1 / P 3 ≤ 3 / P 5 ≤ 5					
Torsionnal rigidity ^{e)}	C _{t2}	[Nm/arcmin]	9	10.7	11	9.9	7.7	
Noise ⁱ⁾	L _{pA}	[dB(A)]	< 62					
Max. permitted housing temperature ^{g)}	T	[°C]	90					
Protection class			IP 65					
Direction of rotation			Same way input / output					
Max. radial force on output shaft ^{f)}	F _{rmax}	[N]	Center of output shaft: 4 200 / End of output shaft: 3 285					
Max. axial force on output shaft ^{f)}	F _{amax}	[N]	3 600					
Color			Red, RAL 3003					
Inertia in kg.cm ² ^{h)}	Ø11	J ₁	[kgcm ²]	1.103	0.881	0.796	0.724	0.688
	Ø14			1.093	0.871	0.786	0.714	0.678
	Ø19			1.856	1.634	1.549	1.477	1.441
	Ø24			2.184	1.962	1.877	1.805	1.769

- a) Nominal output torque when operating at n_{1N}.
- b) 1 000 cycles per hour max.
- c) Valid for an ambient temperature of 20°C and T_{2N}.
At higher ambient temperatures, please reduce speed.
- d) Valid 1000 times the gearbox life.

- e) Valid for an Input Ø of 19 mm in I-stage and 14 mm in 2-stage.
- f) Values for 300 rpm.
- g) For other temperatures, please contact us. Nominal output torque when operating at n_{1N}.
- h) Depending on the motor output shaft Ø.
- i) With i=10 and n_{1N}=3000 rpm no load.

Rack



			Pinion 1			Pinion 2		
			Q6	Q7	Q9	Q6	Q7	Q9
Max acceleration force	F _{2B}	[N]	7 490	2 963	5 036	10 570	2 813	7 620
Max acceleration torque	T _{2B}	[Nm]	159	63	107	224	60	162
Precision			PI		P5	PI		P5
Feed force			High	Medium	Elevated	High	Medium	Elevated

Above values for rack and pinion take into consideration a number of load cycles:
1x10⁶ for the rack; 1x10⁷ for the pinion. Both in pulsating operation.

For proper sizing follow flowchart
calculate your ideal drive train
on pages 136 et seq.

More on the technical datasheets
your ideal drive train on pages
120 et seq.

Input

A	for motor shaft	$L \leq 50$	$\varnothing d \leq 19$	result in LA
B	for motor shaft	$50 < L \leq 55$	$\varnothing d \leq 24$	result in LB
C	for motor shaft	$55 < L \leq 60$	$\varnothing d \leq 24$	result in LC

		1-stage	2-stage
LA	[mm]	117.1	154.1
LB	[mm]	125.6	162.1
LC	[mm]	130.1	167.1

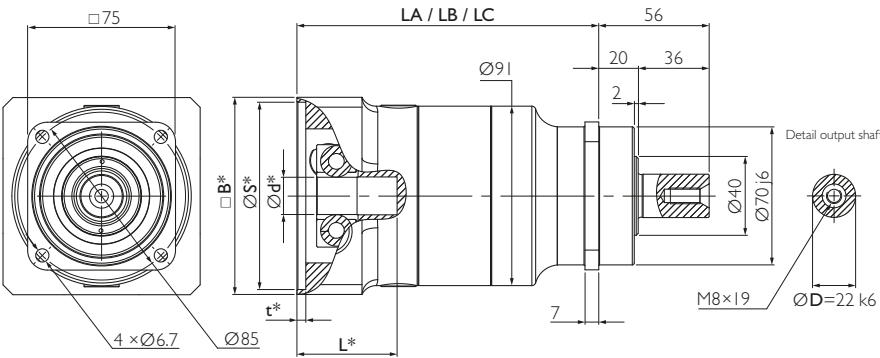

* depending on the motor. See pages 130 et seq.



Example NRH 080 A0, 2-stage

Output

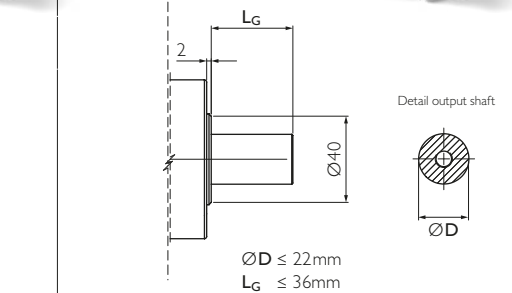

Option 3 on request. Adjustments can reduce capacity.

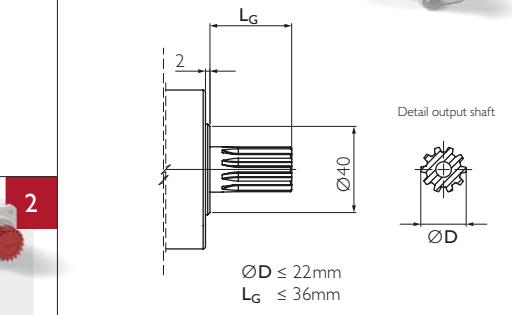
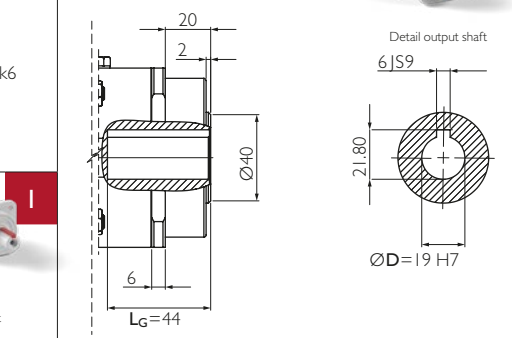

Option 5 on request. Adjustments can reduce capacity.

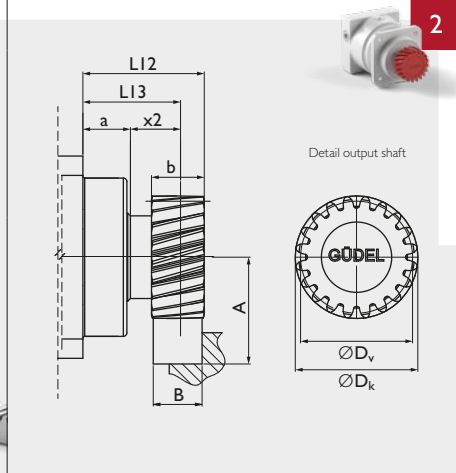
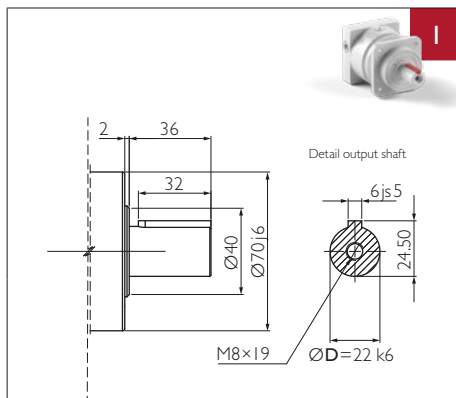

Your ideal drive train

Function Package with gearbox, rack and pinion from Güdel

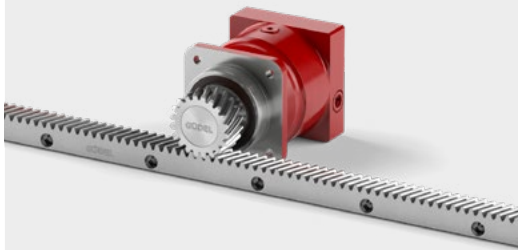

Pinion

	m_n	P_t	z	A	b	D_k	D_0	D_v	L12	L13	x2	a	M	
Pinion 1	[-]	2	6.66	20	43.221	25	46.44	42.441	42.441	52.5	40.0	20.0	20	0.3
Pinion 2	[-]	2.5	8.33	16	43.471	25	48.94	42.441	43.941	52.5	40.0	20.0	20	0.3

m_n : Normal module, P_t : Transverse pitch [mm], z : Number of teeth, D_0 : Pitch circle diameter for calculation, D_v : Pitch circle diameter for design, M: Weight [kg]

Available ratios *	i		2-stage										
			12	16	20	25	30	35	40	50	70	100	
Nominal torque S5 ^{a)}	T _{2N}	[Nm]	75	90	90	90	75	90	90	90	90	60	
Acceleration torque S5 ^{b)}	T _{2B}	[Nm]	85	110	110	110	90	110	110	110	110	90	
Nominal input speed S5 ^{c)}	n _{1N}	[rpm]	3 300	3 500	3 500	3 500	3 500	3 500	3 500	3 800	4 500	4 500	
Maximum input speed S5	n _{1max}	[rpm]	6 000	6 000	6 000	6 000	6 000	6 000	6 000	6 000	6 000	6 000	
Nominal torque S1 ^{a)}	T _{2N}	[Nm]	50	50	50	50	40	50	50	50	50	35	
Acceleration torque S1 ^{b)}	T _{2B}	[Nm]	72	72	72	72	72	72	72	72	72	47	
Nominal input speed S1 ^{c)}	n _{1N}	[rpm]	2 300	3 100	3 100	3 100	3 100	3 100	3 100	3 400	4 000	4 000	
Maximum input speed S1	n _{1max}	[rpm]	3 300	3 300	3 500	3 500	3 500	3 500	3 500	3 800	4 500	4 500	
Emergency stop torque ^{d)}	T _{2not}	[Nm]	250	250	250	250	250	250	250	250	250	200	
Efficiency	η	[%]	94										
Lifetime	L _h	[h]	> 20 000										
Weight	M	[kg]	5.5										
Angular backlash	i _c	[arcmin]	Precision P 1 ≤ 1 / P 3 ≤ 3 / P 5 ≤ 5										
Torsionnal rigidity ^{e)}	C _{t2}	[Nm/arcmin]	8.7	10.7	10.7	10.6	8.7	10.6	10	9.9	9.3	7.3	
Noise ^{f)}	L _{pA}	[dB(A)]	< 62										
Max. permitted housing temperature ^{g)}	T	[°C]	90										
Protection class			IP 65										
Direction of rotation			Same way input / output										
Max. radial force on output shaft ^{f)}	F _{rmax}	[N]	Center of output shaft: 4 200 / End of output shaft: 3 285										
Max. axial force on output shaft ^{f)}	F _{amax}	[N]	3 600										
Color			Red, RAL 3003										
Inertia in kg.cm ² ^{h)}	Ø 11	J ₁	[kgcm ²]	0.864	0.851	0.845	0.773	0.685	0.713	0.683	0.682	0.682	0.681
	Ø 14			0.854	0.841	0.835	0.763	0.675	0.703	0.673	0.672	0.672	0.671
	Ø 19			1.617	1.604	1.598	1.526	1.438	1.466	1.436	1.435	1.435	1.434
	Ø 24			1.945	1.932	1.926	1.854	1.766	1.794	1.764	1.763	1.763	1.762

- * Other ratios available. 9, 15, 21, 27, 28, 49 on request.
- a) Nominal output torque when operating at n_{1N}.
- b) 1000 cycles per hour max.
- c) Valid for an ambient temperature of 20°C and T_{2N}.
At higher ambient temperatures, please reduce speed.
- d) Valid 1000 times the gearbox life.

- e) Valid for an Input Ø of 19 mm in 1-stage and 14 mm in 2-stage.
- f) Values for 300 rpm.
- g) For other temperatures, please contact us. Nominal output torque when operating at n_{1N}.
- h) Depending on the motor output shaft Ø.
- i) With i=10 and n_{1N}=3000 rpm no load.

Rack



			Pinion 1			Pinion 2		
			Q6	Q7	Q9	Q6	Q7	Q9
Max acceleration force	F _{2B}	[N]	7 490	2 963	5 036	10 570	2 813	7620
Max acceleration torque	T _{2B}	[Nm]	159	63	107	224	60	162
Precision			PI		P5	PI		P5
Feed force			High	Medium	Elevated	High	Medium	Elevated

Above values for rack and pinion take into consideration a number of load cycles: 1x10⁶ for the rack; 1x10⁷ for the pinion. Both in pulsating operation.

For proper sizing follow flowchart **calculate your ideal drive train** on pages 136 et seq.

More on the technical datasheets **your ideal drive train** on pages 120 et seq.

Input

A	for motor shaft	$L \leq 54$	$\varnothing d \leq 24$	result in LA
B	for motor shaft	$54 < L \leq 65$	$\varnothing d \leq 38$	result in LB
C	for motor shaft	$65 < L \leq 80$	$\varnothing d \leq 38$	result in LC

		I-stage	2-stage
LA	[mm]	130	181
LB	[mm]	141	192
LC	[mm]	161	212

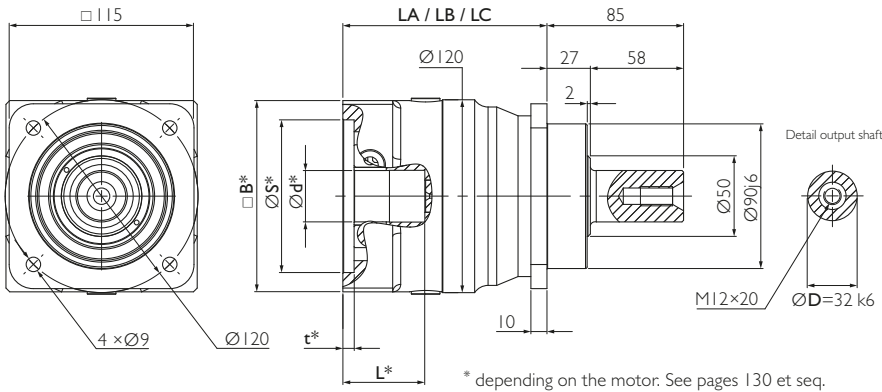

* depending on the motor. See pages 130 et seq.



Example NRH 100 A0, I-stage

Output

Standard

Optional

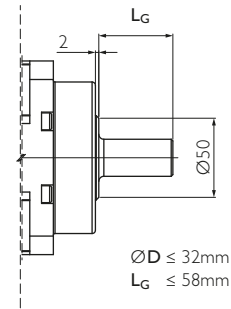

Detail output shaft

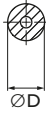

$\varnothing D \leq 32\text{mm}$
 $L_G \leq 58\text{mm}$

Option 3 on request. Adjustments can reduce capacity.

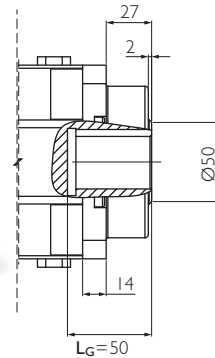

Detail output shaft

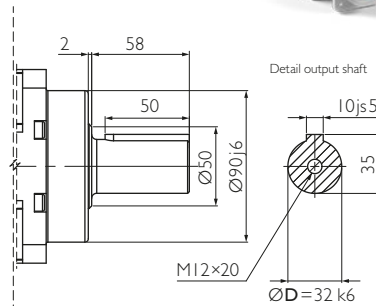
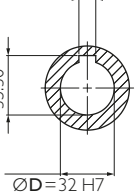

Detail output shaft

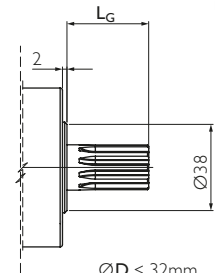
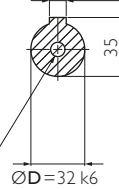

Detail output shaft



$\varnothing D \leq 32\text{mm}$
 $L_G \leq 58\text{mm}$

Option 5 on request. Adjustments can reduce capacity.

Your ideal drive train

Function Package with gearbox, rack and pinion from Güdel

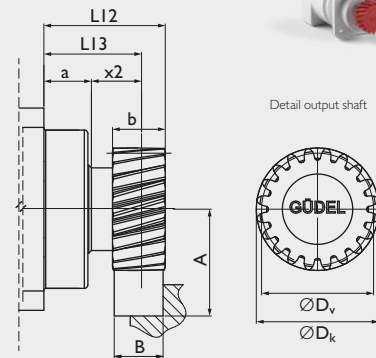
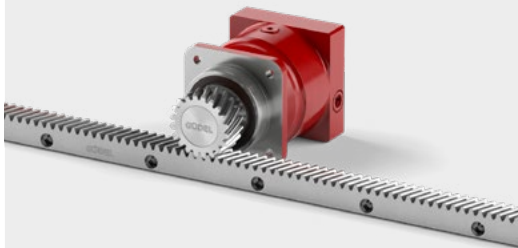

Detail output shaft

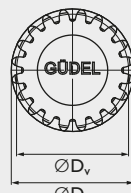

Material 16MnCr5 DIN 1.7131
Teeth pressure angle $\alpha = 20^\circ$, helical teeth left, $19^\circ 31' 42''$ hardened (58⁺⁴ HRC), ground, crowned
Quality 6f24 DIN 3962 / 63 / 67

Pinion



	m_n	P_t	z	A	b	D_k	D_0	D_v	LI2	LI3	x2	a	M	
Pinion 1	[-]	2	6.66	25	48.526	25	57.05	53.052	53.052	63.3	51.0	24.0	27	0.4
Pinion 2	[-]	3	10.00	20	57.831	30	69.66	63.662	63.662	69.0	54.0	27.0	27	0.7

m_n : Normal module, P_t : Transverse pitch [mm], z : Number of teeth, D_0 : Pitch circle diameter for calculation, D_v : Pitch circle diameter for design, M: Weight [kg]

Available ratios	i		I-stage					
			3	4	5	7	10	
Nominal torque S5 ^{a)}	T _{2N}	[Nm]	200	260	270	250	150	
Acceleration torque S5 ^{b)}	T _{2B}	[Nm]	320	350	350	330	265	
Nominal input speed S5 ^{c)}	n _{1N}	[rpm]	2 500	2 500	2 500	2 800	2 800	
Maximum input speed S5	n _{1max}	[rpm]	4 000	4 500	4 500	4 500	4 500	
Nominal torque S1 ^{a)}	T _{2N}	[Nm]	–	175	175	175	115	
Acceleration torque S1 ^{b)}	T _{2B}	[Nm]	–	250	250	250	190	
Nominal input speed S1 ^{c)}	n _{1N}	[rpm]	–	2 200	2 200	2 500	2 500	
Maximum input speed S1	n _{1max}	[rpm]	–	2 500	2 500	2 800	2 800	
Emergency stop torque ^{d)}	T _{2not}	[Nm]	500	630	630	630	630	
Efficiency	η	[%]	97					
Lifetime	L _h	[h]	> 20 000					
Weight	M	[kg]	7					
Angular backlash	i _c	[arcmin]	Precision P 1 ≤ 1 / P 3 ≤ 3 / P 5 ≤ 5					
Torsionnal rigidity ^{e)}	C _{t2}	[Nm/arcmin]	34	42	44	44	37	
Noise ⁱ⁾	L _{pA}	[dB(A)]	< 62					
Max. permitted housing temperature ^{g)}	T	[°C]	90					
Protection class			IP 65					
Direction of rotation			Same way input / output					
Max. radial force on output shaft ^{f)}	F _{rmax}	[N]	Center of output shaft: 6 600 / End of output shaft: 4 300					
Max. axial force on output shaft ^{f)}	F _{amax}	[N]	5 700					
Color			Red, RAL 3003					
Inertia in kg.cm ² ^{h)}	Ø11	J ₁	[kgcm ²]	4.56	3.061	2.504	2.047	1.806
	Ø14			4.54	3.041	2.484	2.027	1.786
	Ø19			5.3	3.801	3.244	2.787	2.546
	Ø24			5.62	4.121	3.564	3.107	2.866
	Ø32			6.66	5.161	4.604	4.147	3.906
	Ø35			12.79	11.291	10.734	10.277	10.036
	Ø38			12.76	11.261	10.704	10.247	10.006

- a) Nominal output torque when operating at n_{1N}.
- b) 1000 cycles per hour max.
- c) Valid for an ambient temperature of 20°C and T_{2N}.
At higher ambient temperatures, please reduce speed.
- d) Valid 1000 times the gearbox life.

- e) Valid for an Input Ø of 24 mm in I-stage and 19 mm in 2-stage.
- f) Values for 300 rpm.
- g) For other temperatures, please contact us. Nominal output torque when operating at n_{1N}.
- h) Depending on the motor output shaft Ø.
- i) With i=10 and n_{1N}=3000 rpm no load.

Rack



			Pinion 1			Pinion 2		
			Q6	Q7	Q9	Q6	Q7	Q9
Max acceleration force	F _{2B}	[N]	7 540	4 107	4 805	16 163	7 565	12 980
Max acceleration torque	T _{2B}	[Nm]	200	109	127	515	241	413
Precision			PI		P5	PI		P5
Feed force			High	Medium	Elevated	High	Medium	Elevated

Above values for rack and pinion take into consideration a number of load cycles: 1x10⁶ for the rack; 1x10⁷ for the pinion. Both in pulsating operation.

For proper sizing follow flowchart **calculate your ideal drive train** on pages 136 et seq.

More on the technical datasheets **your ideal drive train** on pages 120 et seq.

Input

A	for motor shaft	$L \leq 54$	$\varnothing d \leq 24$	result in LA
B	for motor shaft	$54 < L \leq 65$	$\varnothing d \leq 38$	result in LB
C	for motor shaft	$65 < L \leq 80$	$\varnothing d \leq 38$	result in LC

		1-stage	2-stage
LA	[mm]	130	181
LB	[mm]	141	192
LC	[mm]	161	212

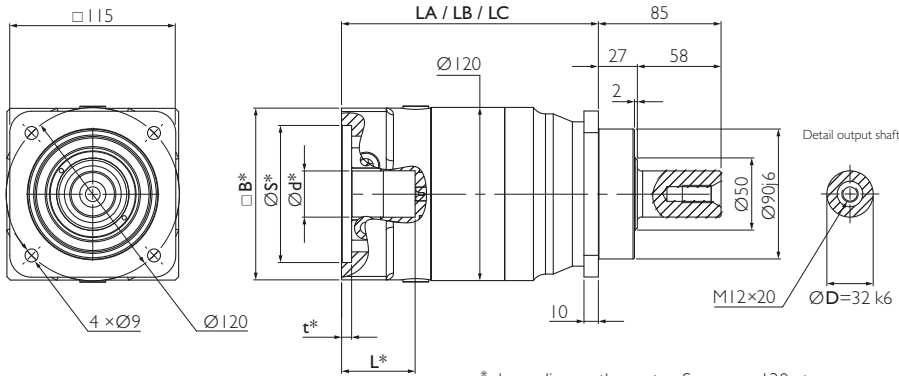

Example NRH 100 A0, 2-stage

Output

Standard

Optional

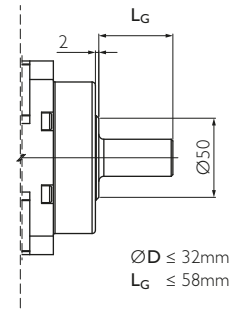

Detail output shaft

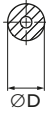

$\varnothing D \leq 32\text{mm}$
 $L_G \leq 58\text{mm}$

Option 3 on request. Adjustments can reduce capacity.

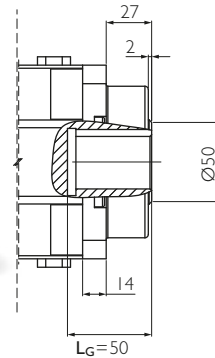

Detail output shaft

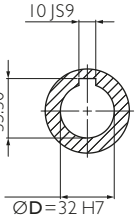

* depending on the motor. See pages 130 et seq.

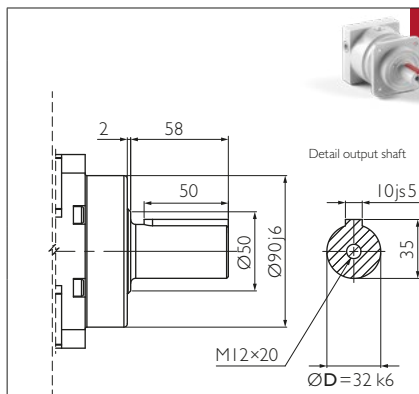

Detail output shaft

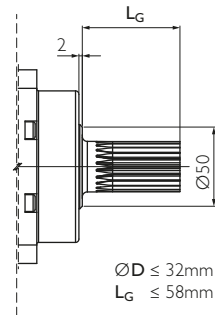
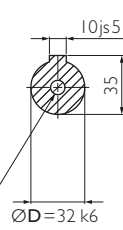

Detail output shaft



$\varnothing D \leq 32\text{mm}$
 $L_G \leq 58\text{mm}$

Option 5 on request. Adjustments can reduce capacity.

Your ideal drive train

Function Package with gearbox, rack and pinion from Güdel

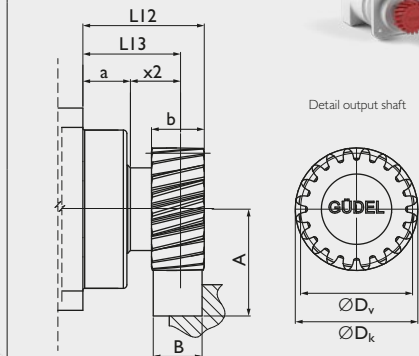
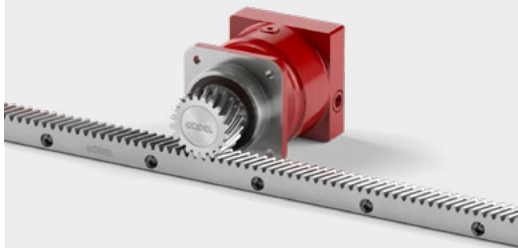

Detail output shaft

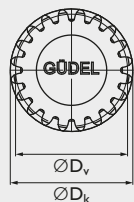

Material 16MnCr5 DIN 1.7131
Teeth pressure angle $\alpha = 20^\circ$, helical teeth left, 19°31'42" hardened (58⁺⁴HRC), ground, crowned
Quality 6f24 DIN 3962 / 63 / 67

Pinion



	m_n	P_t	z	A	b	D_k	D_0	D_v	L12	L13	x2	a	M	
Pinion 1	[-]	2	6.66	25	48.526	25	57.05	53.052	53.052	63.3	51.0	24.0	27	0.4
Pinion 2	[-]	3	10.00	20	57.831	30	69.66	63.662	63.662	69.0	54.0	27.0	27	0.7

m_n : Normal module, P_t : Transverse pitch [mm], z : Number of teeth, D_0 : Pitch circle diameter for calculation, D_v : Pitch circle diameter for design, M: Weight [kg]

Available ratios *	i		2-stage										
			12	16	20	25	30	35	40	50	70	100	
Nominal torque S5 ^{a)}	T _{2N}	[Nm]	200	260	270	270	200	270	260	270	250	150	
Acceleration torque S5 ^{b)}	T _{2B}	[Nm]	320	350	350	350	320	350	350	320	330	265	
Nominal input speed S5 ^{c)}	n _{1N}	[rpm]	2 900	3 100	3 100	3 100	3 100	3 100	3 100	3 500	4 200	4 200	
Maximum input speed S5	n _{1max}	[rpm]	4 500	4 500	4 500	4 500	4 500	4 500	4 500	4 500	4 500	4 500	
Nominal torque S1 ^{a)}	T _{2N}	[Nm]	175	175	175	175	175	175	175	175	175	115	
Acceleration torque S1 ^{b)}	T _{2B}	[Nm]	250	250	250	250	250	250	250	250	250	190	
Nominal input speed S1 ^{c)}	n _{1N}	[rpm]	2 000	2 200	2 800	2 800	2 800	2 800	2 800	3 100	3 800	3 800	
Maximum input speed S1	n _{1max}	[rpm]	2 900	3 100	3 100	3 100	3 100	3 100	3 100	3 500	4 200	4 200	
Emergency stop torque ^{d)}	T _{2not}	[Nm]	630	630	630	630	630	630	630	630	630	630	
Efficiency	η	[%]	94										
Lifetime	L _h	[h]	> 20 000										
Weight	M	[kg]	12										
Angular backlash	j _t	[arcmin]	Precision P 1 ≤ 1 / P 3 ≤ 3 / P 5 ≤ 5										
Torsionnal rigidity ^{e)}	C _{t2}	[Nm/arcmin]	34	44	44	44	34	44	42	44	44	37	
Noise ⁱ⁾	L _{pA}	[dB(A)]	< 62										
Max. permitted housing temperature ^{g)}	T	[°C]	90										
Protection class			IP 65										
Direction of rotation			Same way input / output										
Max. radial force on output shaft ^{f)}	F _{Rmax}	[N]	Center of output shaft: 6 600 / End of output shaft: 4 300										
Max. axial force on output shaft ^{f)}	F _{Amax}	[N]	5 700										
Color			Red, RAL 3003										
Inertia in kg.cm ² ^{h)}	Ø11	J ₁	[kg.cm ²]	2.934	2.841	2.806	2.34	1.786	1.964	1.771	1.765	1.761	1.758
	Ø14			2.914	2.821	2.786	2.32	1.766	1.944	1.751	1.745	1.741	1.738
	Ø19			3.674	3.581	3.546	3.08	2.526	2.704	2.511	2.505	2.501	2.498
	Ø24			3.994	3.901	3.866	3.4	2.846	3.024	2.831	2.825	2.821	2.818
	Ø32			5.034	4.941	4.906	4.44	3.886	4.064	3.871	3.865	3.861	3.858
	Ø35			11.164	11.071	11.036	10.57	10.016	10.194	10.001	9.995	9.991	9.988
	Ø38			11.134	11.041	11.006	10.54	9.986	10.164	9.971	9.965	9.961	9.958

- * Other ratios available. 9, 15, 21, 27, 28, 49 on request.
- a) Nominal output torque when operating at n_{1N}.
- b) 1 000 cycles per hour max.
- c) Valid for an ambient temperature of 20°C and T_{2N}.
At higher ambient temperatures, please reduce speed.
- d) Valid 1 000 times the gear box life.

- e) Valid for an input Ø of 24 mm in 1-stage and 19 mm in 2-stage.
- f) Values for 300 rpm.
- g) For other temperatures, please contact us. Nominal output torque when operating at n_{1N}.
- h) Depending on the motor output shaft Ø.
- i) With i=10 and n_{1N}=3000 rpm no load.

Rack



			Pinion 1			Pinion 2		
			Q6	Q7	Q9	Q6	Q7	Q9
Max acceleration force	F _{2B}	[N]	7 540	4 107	4 805	16 163	7 565	12 980
Max acceleration torque	T _{2B}	[Nm]	200	109	127	515	241	413
Precision			PI		P5	PI		P5
Feed force			High	Medium	Elevated	High	Medium	Elevated

Above values for rack and pinion take into consideration a number of load cycles: 1x10⁶ for the rack; 1x10⁷ for the pinion. Both in pulsating operation.

For proper sizing follow flowchart **calculate your ideal drive train** on pages 136 et seq.

More on the technical datasheets **your ideal drive train** on pages 120 et seq.

Input

- A** for motor shaft $L \leq 62$
- B** for motor shaft $62 < L \leq 115$

		I-stage	2-stage
LA	[mm]	160	193
LB	[mm]	212	204
LC	[mm]		224

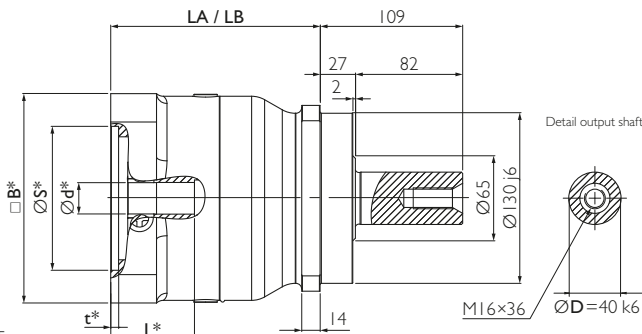
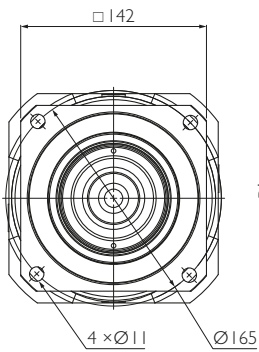

* depending on the motor. See pages 130 et seq.



Example NRH 140 A0, I-stage

Output

Standard

Optional

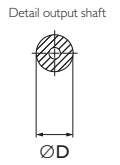
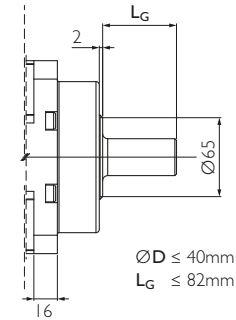

Option 3 on request. Adjustments can reduce capacity.

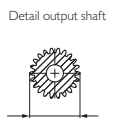
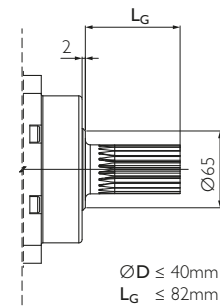
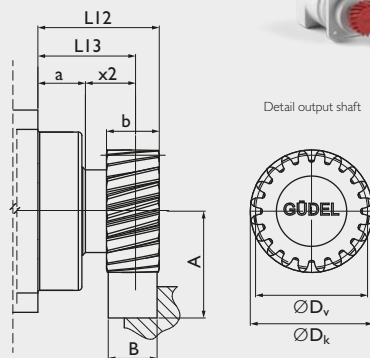
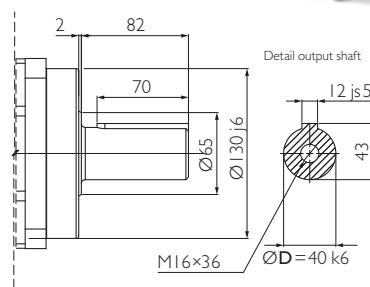
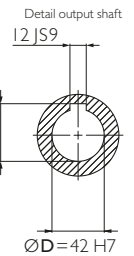
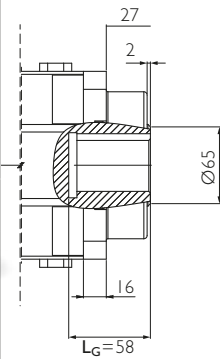

Option 5 on request. Adjustments can reduce capacity.

Material 16MnCr5 DIN 1.7131
 Teeth pressure angle $\alpha = 20^\circ$, helical teeth left, $19^\circ 31' 42''$ hardened (58⁺⁴ HRC), ground, crowned
 Quality 6f24 DIN 3962 / 63 / 67

Your ideal drive train

Function Package with gearbox, rack and pinion from Güdel

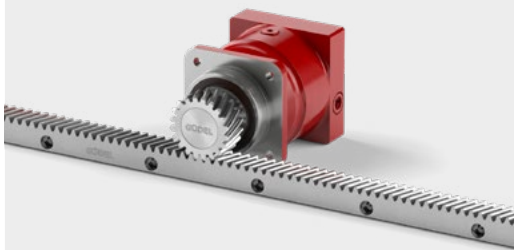

Pinion



	m_n	P_t	z	A	b	D_k	D_0	D_v	L12	L13	x2	a	M	
Pinion 1	[-]	3	10.00	22	61.014	30	76.03	70.028	70.028	69.5	54.5	27.5	27	0.8
Pinion 2	[-]	4	13.33	20	77.441	40	92.88	84.883	84.883	79.0	59.0	32.0	27	1.6

m_n : Normal module, P_t : Transverse pitch [mm], z : Number of teeth, D_0 : Pitch circle diameter for calculation, D_v : Pitch circle diameter for design, M: Weight [kg]

Available ratios	i		I-stage					
			3	4	5	7	10	
Nominal torque S5 ^{a)}	T _{2N}	[Nm]	400	490	500	470	310	
Acceleration torque S5 ^{b)}	T _{2B}	[Nm]	520	650	650	650	500	
Nominal input speed S5 ^{c)}	n _{1N}	[rpm]	2 100	2 100	2 100	2 600	2 600	
Maximum input speed S5	n _{1max}	[rpm]	3 500	4 000	4 000	4 000	4 000	
Nominal torque S1 ^{a)}	T _{2N}	[Nm]	–	260	260	260	130	
Acceleration torque S1 ^{b)}	T _{2B}	[Nm]	–	370	370	370	220	
Nominal input speed S1 ^{c)}	n _{1N}	[rpm]	–	1 900	1 900	2 300	2 300	
Maximum input speed S1	n _{1max}	[rpm]	–	2 100	2 100	2 600	2 600	
Emergency stop torque ^{d)}	T _{2not}	[Nm]	1 300	1 300	1 300	1 300	1 260	
Efficiency	η	[%]	97					
Lifetime	L _h	[h]	> 20 000					
Weight	M	[kg]	15					
Angular backlash	j _t	[arcmin]	Precision P 1 ≤ 1 / P 3 ≤ 3 / P 5 ≤ 5					
Torsionnal rigidity ^{e)}	C _{t2}	[Nm/arcmin]	90	101	107	106	98	
Noise ⁱ⁾	L _{pA}	[dB(A)]	< 62					
Max. permitted housing temperature ^{g)}	T	[°C]	90					
Protection class			IP 65					
Direction of rotation			Same way input / output					
Max. radial force on output shaft ^{f)}	F _{Rmax}	[N]	Center of output shaft: 9 950 / End of output shaft: 6 700					
Max. axial force on output shaft ^{f)}	F _{Amax}	[N]	10 300					
Color			Red, RAL 3003					
Inertia in kg.cm ² ^{h)}	Ø19	J ₁	[kgcm ²]	11.83	7.32	5.647	4.224	3.499
	Ø24			12.15	7.64	5.967	4.544	3.819
	Ø32			18.01	13.5	11.827	10.404	9.679
	Ø35			18.6	14.09	12.417	10.994	10.269
	Ø38			19.07	14.56	12.887	11.464	10.739
	Ø42			19.4	14.89	13.217	11.794	11.069
	Ø48			23.38	18.87	17.197	15.774	15.049

- a) Nominal output torque when operating at n_{1N}.
- b) 1000 cycles per hour max.
- c) Valid for an ambient temperature of 20°C and T_{2N}. At higher ambient temperatures, please reduce speed.
- d) Valid 1000 times the gearbox life.

- e) Valid for an input Ø of 38 mm in I-stage and 24 mm in 2-stage.
- f) Values for 300 rpm.
- g) For other temperatures, please contact us. Nominal output torque when operating at n_{1N}.
- h) Depending on the motor output shaft Ø.
- i) With i=10 and n_{1N}=3000 rpm no load.

Rack



	F _{2B}	[N]	Pinion 1			Pinion 2		
			Q6	Q7	Q9	Q6	Q7	Q9
Max acceleration force	F _{2B}	[N]	16 230	8 715	12 919	28 585	14 084	24 045
Max acceleration torque	T _{2B}	[Nm]	568	305	452	1 213	598	1 021
Precision			PI		P5	PI		P5
Feed force			High	Medium	Elevated	High	Medium	Elevated

Above values for rack and pinion take into consideration a number of load cycles: 1x10⁶ for the rack; 1x10⁷ for the pinion. Both in pulsating operation.

For proper sizing follow flowchart **calculate your ideal drive train** on pages 136 et seq.

More on the technical datasheets **your ideal drive train** on pages 120 et seq.

Input

- A** for motor shaft $L \leq 54$
- B** for motor shaft $54 < L \leq 65$
- C** for motor shaft $65 < L \leq 80$

		1-stage	2-stage
LA	[mm]	160	193
LB	[mm]	212	204
LC	[mm]		224

Output

Standard

Optional

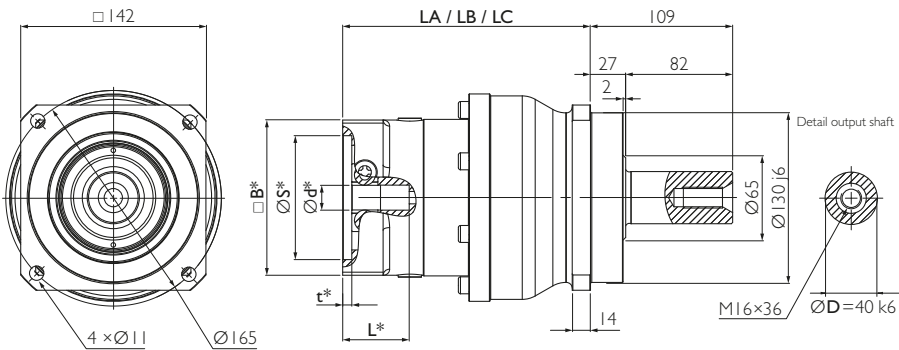

* depending on the motor. See pages 130 et seq.



Example NRH 140 A0, 2-stage

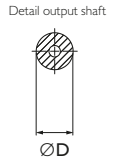
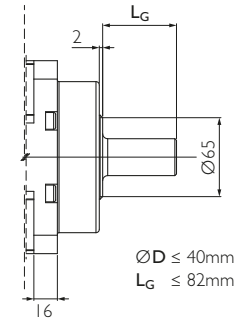

$\varnothing D \leq 40\text{mm}$
 $L_G \leq 82\text{mm}$

Option 3 on request. Adjustments can reduce capacity.

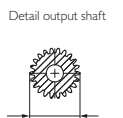
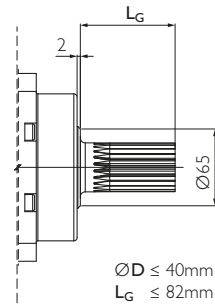
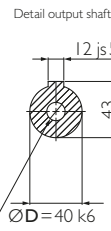
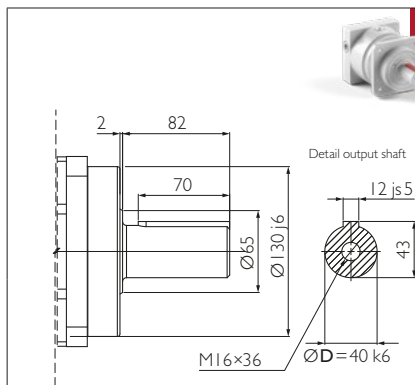
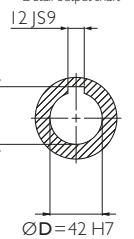
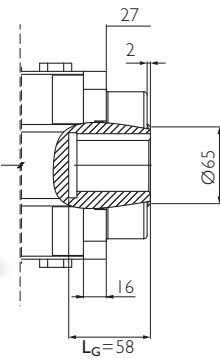

$\varnothing D \leq 40\text{mm}$
 $L_G \leq 82\text{mm}$

Option 5 on request. Adjustments can reduce capacity.

Your ideal drive train

Function Package with gearbox, rack and pinion from Güdel

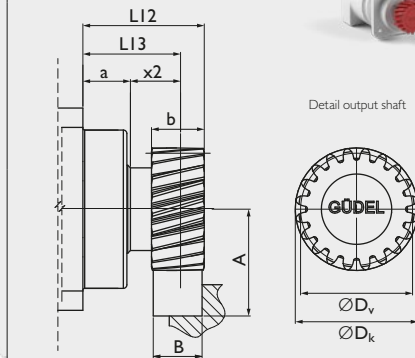
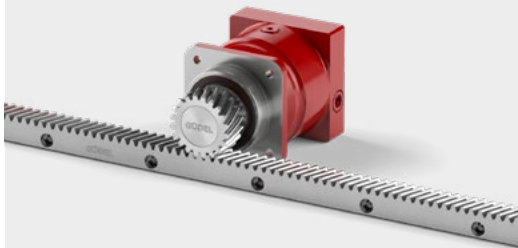

Material 16MnCr5 DIN 1.7131
Teeth pressure angle $\alpha = 20^\circ$, helical teeth left, $19^\circ 31' 42''$ hardened (58⁺⁴HRC), ground, crowned
Quality 6f24 DIN 3962 / 63 / 67

Pinion



	m_n	P_t	z	A	b	D_k	D_0	D_v	L12	L13	x2	a	M	
Pinion 1	[-]	3	10.00	22	61.014	30	76.03	70.028	70.028	69.5	54.5	27.5	27	0.8
Pinion 2	[-]	4	13.33	20	77.441	40	92.88	84.883	84.883	79.0	59.0	32.0	27	1.6

m_n : Normal module, P_t : Transverse pitch [mm], z : Number of teeth, D_0 : Pitch circle diameter for calculation, D_v : Pitch circle diameter for design, M: Weight [kg]

Available ratios *	i		2-stage										
			12	16	20	25	30	35	40	50	70	100	
Nominal torque S5 ^{a)}	T _{2N}	[Nm]	400	490	500	500	400	500	490	500	470	310	
Acceleration torque S5 ^{b)}	T _{2B}	[Nm]	520	650	650	650	600	650	650	650	650	500	
Nominal input speed S5 ^{c)}	n _{1N}	[rpm]	2 700	2 900	2 900	2 900	2 900	2 900	2 900	3 200	3 200	3 900	
Maximum input speed S5	n _{1max}	[rpm]	4 500	4 500	4 500	5 000	5 000	5 000	5 000	5 000	5 000	5 000	
Nominal torque S1 ^{a)}	T _{2N}	[Nm]	260	260	260	260	260	260	260	260	260	150	
Acceleration torque S1 ^{b)}	T _{2B}	[Nm]	370	370	370	370	370	370	370	370	370	220	
Nominal input speed S1 ^{c)}	n _{1N}	[rpm]	1 900	2 600	2 600	2 600	2 600	2 600	2 600	2 900	2 900	3 500	
Maximum input speed S1	n _{1max}	[rpm]	2 700	2 900	2 900	2 900	2 900	2 900	2 900	3 200	3 200	3 900	
Emergency stop torque ^{d)}	T _{2not}	[Nm]	1 300	1 300	1 300	1 300	1 300	1 300	1 300	1 300	1 300	1 260	
Efficiency	η	[%]	94										
Lifetime	L _h	[h]	> 20 000										
Weight	M	[kg]	17										
Angular backlash	j _t	[arcmin]	Precision P 1 ≤ 1 / P 3 ≤ 3 / P 5 ≤ 5										
Torsionnal rigidity ^{e)}	C _{t2}	[Nm/arcmin]	80	91	97	97	80	97	91	97	95	80	
Noise ⁱ⁾	L _{pA}	[dB(A)]	< 62										
Max. permitted housing temperature ^{g)}	T	[°C]	90										
Protection class			IP 65										
Direction of rotation			Same way input / output										
Max. radial force on output shaft ^{f)}	F _{Rmax}	[N]	Center of output shaft: 9 950 / End of output shaft: 6 700										
Max. axial force on output shaft ^{f)}	F _{Amax}	[N]	10 300										
Color			Red, RAL 3003										
Inertia in kg.cm ^{2h)}	Ø14	J ₁	[kgcm ²]	3.251	2.969	2.864	2.369	1.82	1.971	1.775	1.759	1.744	1.737
	Ø19			4.011	3.729	3.624	3.129	2.58	2.731	2.535	2.519	2.504	2.497
	Ø24			4.331	4.049	3.944	3.449	2.9	3.051	2.855	2.839	2.824	2.817
	Ø32			5.371	5.089	4.984	4.489	3.94	4.091	3.895	3.879	3.864	3.857
	Ø35			11.501	11.219	11.114	10.619	10.07	10.221	10.025	10.009	9.994	9.987
	Ø38			11.471	11.189	11.084	10.589	10.04	10.191	9.995	9.979	9.964	9.957

* Other ratios available. 9, 15, 21, 27, 28, 49 on request.

- a) Nominal output torque when operating at n_{1N}.
- b) 1 000 cycles per hour max.
- c) Valid for an ambient temperature of 20°C and T_{2N}.
At higher ambient temperatures, please reduce speed.
- d) Valid 1 000 times the gearbox life.

e) Valid for an input Ø of 38 mm in 1-stage and 24 mm in 2-stage.

- f) Values for 300 rpm.
- g) For other temperatures, please contact us. Nominal output torque when operating at n_{1N}.
- h) Depending on the motor output shaft Ø.
- i) With i=10 and n_{1N}=3000 rpm no load.

Rack



			Pinion 1			Pinion 2		
			Q6	Q7	Q9	Q6	Q7	Q9
Max acceleration force	F _{2B}	[N]	16 230	8 715	12 919	28 585	14 084	24 045
Max acceleration torque	T _{2B}	[Nm]	568	305	452	1 213	598	1 021
Precision			PI		P5	PI		P5
Feed force			High	Medium	Elevated	High	Medium	Elevated

Above values for rack and pinion take into consideration a number of load cycles:
1x10⁶ for the rack; 1x10⁷ for the pinion. Both in pulsating operation.

For proper sizing follow flowchart
calculate your ideal drive train
on pages 136 et seq.

More on the technical datasheets
your ideal drive train on pages
120 et seq.

Input

A	for motor shaft	$L \leq 50$	$\varnothing d \leq 19$	result in LA
B	for motor shaft	$50 < L \leq 55$	$\varnothing d \leq 24$	result in LB
C	for motor shaft	$55 < L \leq 60$	$\varnothing d \leq 24$	result in LC



		I-stage	2-stage
LA	[mm]	108	145
LB	[mm]	116	153
LC	[mm]	121	158

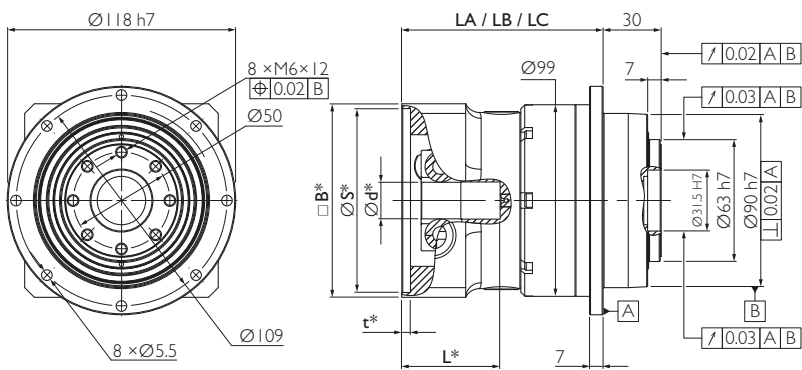

* depending on the motor. See pages 130 et seq.



Example NRHP 080 A0, I-stage

Your ideal drive train

Function Package with gearbox, rack and pinion from Güdel

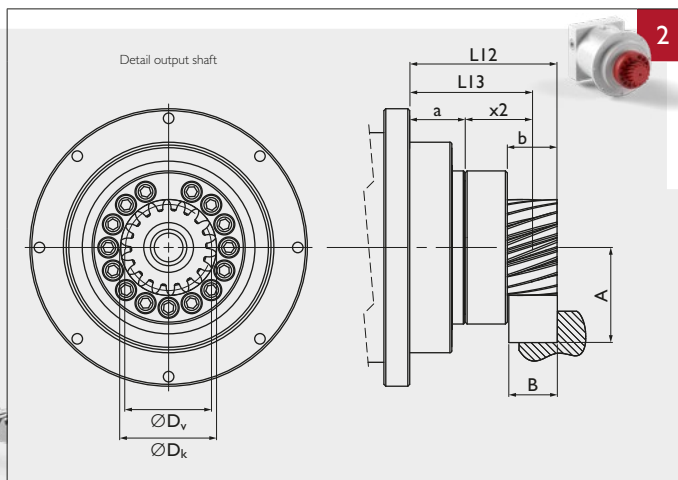
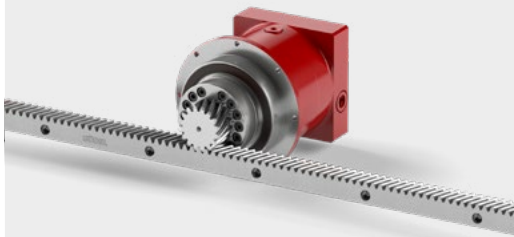

Material 16MnCr5
DIN 1.7131
Teeth pressure angle $\alpha = 20^\circ$,
helical teeth left,
 $19^\circ 31' 42''$,
hardened (58^{+1} HRC),
ground, crowned
Quality 6f24 DIN 3962 / 63 / 67

Pinion



	m_n	P_t	z	A	b	D_k	D_0	D_v	L12	L13	x2	a	M	
Pinion I	[-]	2	6.66	16	39.577	26	39.15	33.953	35.153	75.0	62.0	32.0	30	0.6

m_n : Normal module, P_t : Transverse pitch [mm], z : Number of teeth, D_0 : Pitch circle diameter for calculation, D_v : Pitch circle diameter for design, M: Weight [kg]

Available ratios	i		I-stage						
			3	4	5	7	10		
Nominal torque S5 ^{a)}	T _{2N}	[Nm]	65	75	76	76	60		
Acceleration torque S5 ^{b)}	T _{2B}	[Nm]	85	110	110	110	90		
Nominal input speed S5 ^{c)}	n _{1N}	[rpm]	2 300	2 300	2 900	3 100	3 100		
Maximum input speed S5	n _{1max}	[rpm]	4 000	5 000	6 000	6 000	6 000		
Nominal torque S1 ^{a)}	T _{2N}	[Nm]	–	50	50	50	35		
Acceleration torque S1 ^{b)}	T _{2B}	[Nm]	–	72	72	72	44		
Nominal input speed S1 ^{c)}	n _{1N}	[rpm]	–	2 000	2 000	2 200	2 200		
Maximum input speed S1	n _{1max}	[rpm]	–	2 900	2 900	3 100	3 100		
Emergency stop torque ^{d)}	T _{2not}	[Nm]	250	250	250	250	200		
Efficiency	η	[%]	97						
Lifetime	L _h	[h]	> 20 000						
Weight	M	[kg]	4.9						
Angular backlash	j _c	[arcmin]	Precision P 1 ≤ 1 / P 3 ≤ 3 / P 5 ≤ 5						
Tilting moment	M _{kmax}	[Nm]	348						
Torsionnal rigidity ^{e)}	C _{t2}	[Nm/arcmin]	32	38	40	36	28		
Tilting rigidity ^{e)}	C _{t2}	[Nm/arcmin]	252						
Noise ⁱ⁾	L _{pA}	[dB(A)]	< 62						
Max. permitted housing temperature ^{g)}	T	[°C]	90						
Protection class			IP 65						
Direction of rotation			Same way input / output						
Max. axial force on output shaft ^{f)}	F _{amax}	[N]	2 300						
Color			Red, RAL 3003						
Inertia in kg.cm ² ^{h)}	Ø	J ₁	[kgcm ²]	Ø 11	1.897	1.327	1.083	0.871	0.759
				Ø 14	1.887	1.317	1.073	0.861	0.749
				Ø 19	2.65	2.08	1.836	1.624	1.512
				Ø 24	2.978	2.408	2.164	1.952	1.84

- a) Nominal output torque when operating at n_{1N}.
- b) 1000 cycles per hour max.
- c) Valid for an ambient temperature of 20°C and T_{2N}.
At higher ambient temperatures, please reduce speed.
- d) Valid 1000 times the gearbox life.

- e) Valid for an Input Ø of 19 mm in I-stage and 14 mm in 2-stage.
- f) Values for 300 rpm.
- g) For other temperatures, please contact us. Nominal output torque when operating at n_{1N}.
- h) Depending on the motor output shaft Ø.
- i) With i=10 and n_{1N}=3000 rpm no load.

Rack



			Pinion I		
			Q6	Q7	Q9
Max acceleration force	F _{2B}	[N]	7 075	1 760	4 752
Max acceleration torque	T _{2B}	[Nm]	120	30	81
Precision			P1		P5
Feed force			High	Medium	Elevated

Above values for rack and pinion take into consideration a number of load cycles: 1x10⁶ for the rack; 1x10⁷ for the pinion. Both in pulsating operation.

For proper sizing follow flowchart calculate your ideal drive train on pages 136 et seq.

More on the technical datasheets your ideal drive train on pages 120 et seq.

Input

A	for motor shaft	$L \leq 50$	$\varnothing d \leq 19$	result in LA
B	for motor shaft	$50 < L \leq 55$	$\varnothing d \leq 24$	result in LB
C	for motor shaft	$55 < L \leq 60$	$\varnothing d \leq 24$	result in LC



		1-stage	2-stage
LA	[mm]	108	145
LB	[mm]	116	153
LC	[mm]	121	158

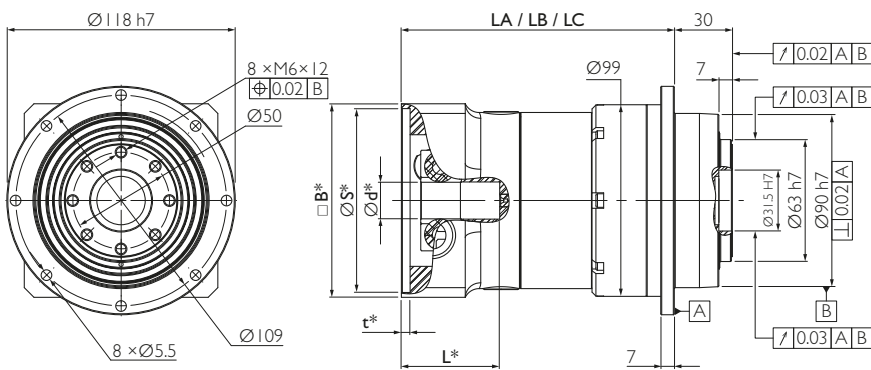

* depending on the motor. See pages 130 et seq.



Example NRHP 080 A0, 2-stage

Your ideal drive train

Function Package with gearbox, rack and pinion from Güdel

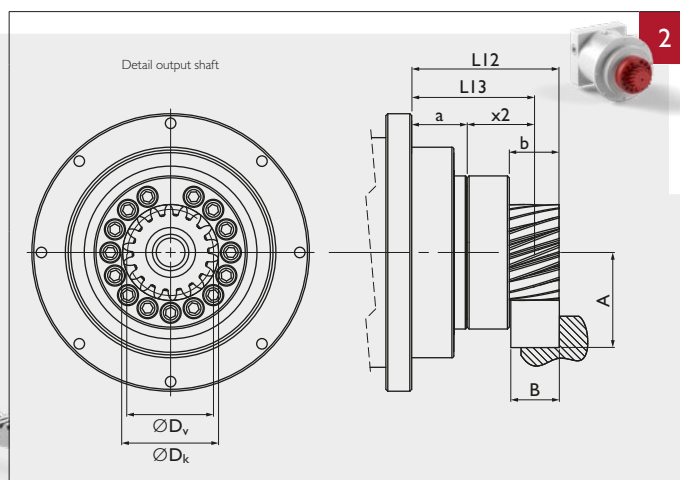
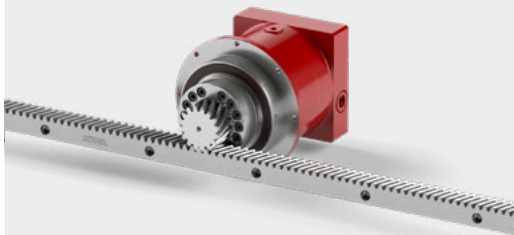

Material 16MnCr5
DIN 1.7131
Teeth pressure angle $\alpha = 20^\circ$,
helical teeth left,
 $19^\circ 31' 42''$,
hardened (58^{+1} HRC),
ground, crowned
Quality 6f24 DIN 3962 / 63 / 67

Pinion



	m_n	P_t	z	A	b	D_k	D_0	D_v	L12	L13	x2	a	M	
Pinion I	[-]	2	6.66	16	39.577	26	39.15	33.953	35.153	75.0	62.0	32.0	30	0.6

m_n : Normal module, P_t : Transverse pitch [mm], z : Number of teeth, D_0 : Pitch circle diameter for calculation, D_v : Pitch circle diameter for design, M: Weight [kg]

Available ratios *	i		2-stage										
			12	16	20	25	30	35	40	50	70	100	
Nominal torque S5 ^{a)}	T _{2N}	[Nm]	75	90	90	90	75	90	90	90	90	60	
Acceleration torque S5 ^{b)}	T _{2B}	[Nm]	85	110	110	110	90	110	110	110	110	90	
Nominal input speed S5 ^{c)}	n _{1N}	[rpm]	3 600	3 600	3 600	3 600	3 600	3 500	3 500	3 800	4 500	4 500	
Maximum input speed S5	n _{1max}	[rpm]	6 000	6 000	6 000	6 000	6 000	6 000	6 000	6 000	6 000	6 000	
Nominal torque S1 ^{a)}	T _{2N}	[Nm]	50	50	50	50	40	50	50	50	50	35	
Acceleration torque S1 ^{b)}	T _{2B}	[Nm]	72	72	72	72	72	72	72	72	72	47	
Nominal input speed S1 ^{c)}	n _{1N}	[rpm]	2 300	2 500	2 500	2 500	2 500	2 500	2 500	3 000	2 800	3 100	
Maximum input speed S1	n _{1max}	[rpm]	3 300	3 500	3 500	3 500	3 500	3 500	3 500	3 800	4 000	4 500	
Emergency stop torque ^{d)}	T _{2not}	[Nm]	250	250	250	250	250	250	250	250	250	200	
Efficiency	η	[%]	94										
Lifetime	L _h	[h]	> 20 000										
Weight	M	[kg]	6.5										
Angular backlash	i _c	[arcmin]	Precision P 1 ≤ 1 / P 3 ≤ 3 / P 5 ≤ 5										
Tilting moment	M _{kmax}	[Nm]	348										
Torsionnal rigidity ^{e)}	C _{t2}	[Nm/arcmin]	32	38	38	39	32	39	35	36	34	27	
Tilting rigidity ^{e)}	C _{t2}	[Nm/arcmin]	252										
Noise ⁱ⁾	L _{pA}	[dB(A)]	< 62										
Max. permitted housing temperature ^{g)}	T	[°C]	90										
Protection class			IP 65										
Direction of rotation			Same way input / output										
Max. axial force on output shaft ^{f)}	F _{amax}	[N]	2 300										
Color			Red, RAL 3003										
Inertia in kg.cm ² ^{h)}	Ø11	J ₁	[kgcm ²]	0.937	0.937	0.886	0.8	0.693	0.727	0.688	0.685	0.683	0.6559
	Ø14			0.927	0.927	0.876	0.79	0.683	0.717	0.678	0.675	0.673	0.6459
	Ø19			1.69	1.69	1.639	1.553	1.446	1.48	1.441	1.438	1.436	1.4089
	Ø24			2.018	2.018	1.967	1.881	1.774	1.808	1.769	1.766	1.764	1.7369

* Other ratios available. 9, 15, 21, 27, 28, 49 on request.

- a) Nominal output torque when operating at n_{1N}.
- b) 1000 cycles per hour max.
- c) Valid for an ambient temperature of 20°C and T_{2N}. At higher ambient temperatures, please reduce speed.
- d) Valid 1000 times the gearbox life.

- e) Valid for an Input Ø of 19 mm in 1-stage and 14 mm in 2-stage.
- f) Values for 300 rpm.
- g) For other temperatures, please contact us. Nominal output torque when operating at n_{1N}.
- h) Depending on the motor output shaft Ø.
- i) With i=10 and n_{1N}=3000 rpm no load.

Rack



			Pinion I		
			Q6	Q7	Q9
Max acceleration force	F _{2B}	[N]	7 075	1 760	4 752
Max acceleration torque	T _{2B}	[Nm]	120	30	81
Precision			P1		P5
Feed force			High	Medium	Elevated

Above values for rack and pinion take into consideration a number of load cycles: 1x10⁶ for the rack; 1x10⁷ for the pinion. Both in pulsating operation.

For proper sizing follow flowchart calculate your ideal drive train on pages 136 et seq.

More on the technical datasheets your ideal drive train on pages 120 et seq.

Input

A	for motor shaft	$L \leq 54$	$\varnothing d \leq 24$	result in LA
B	for motor shaft	$54 < L \leq 65$	$\varnothing d \leq 38$	result in LB
C	for motor shaft	$65 < L \leq 80$	$\varnothing d \leq 38$	result in LC



		I-stage	2-stage
LA	[mm]	132.1	183.1
LB	[mm]	143.1	194.1
LC	[mm]	163.1	214.1

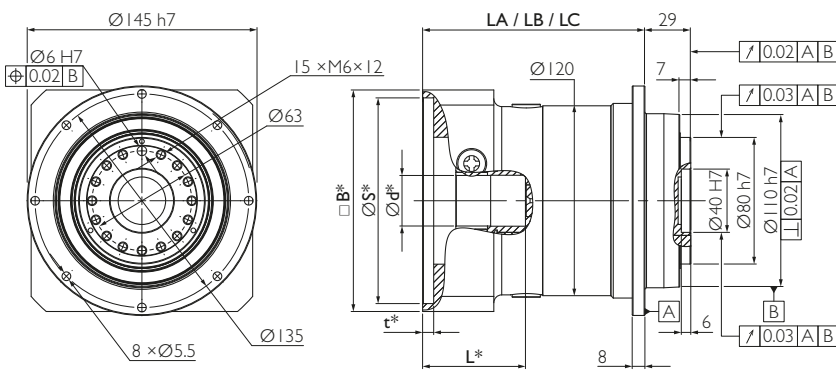

* depending on the motor. See pages 130 et seq.



Example NRHP 100 A0, I-stage

Your ideal drive train

Function Package with gearbox, rack and pinion from Güdel



Pinion

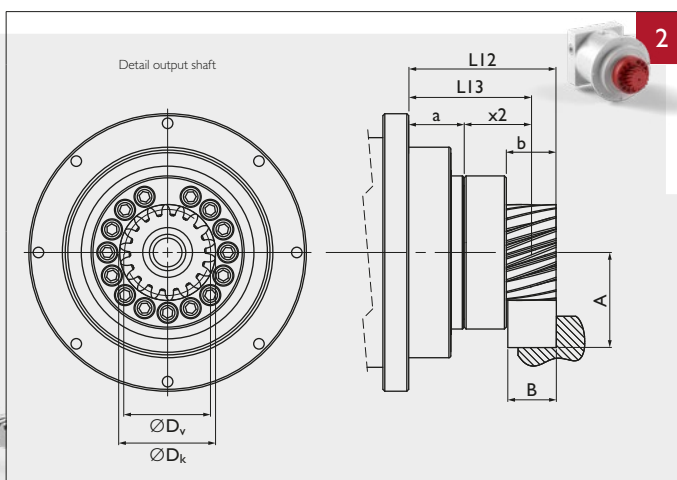

Material 16MnCr5
DIN 1.7131
Teeth pressure angle $\alpha = 20^\circ$,
helical teeth left,
 $19^\circ 31' 42''$,
hardened (58^{+1} HRC),
ground, crowned
Quality 6f24 DIN 3962 / 63 / 67

	m_n	P_t	z	A	b	D_k	D_0	D_v	L12	L13	x2	a	M	
Pinion 1	[-]	2	6.66	16	39.577	26	39.15	33.953	35.153	77.0	64.0	35.0	29	1.0
Pinion 2	[-]	2	6.66	21	44.282	26	48.56	44.563	44.563	77.0	64.0	35.0	29	1.0
Pinion 3	[-]	2.5	8.33	16	43.471	26	48.94	42.441	43.941	77.0	64.0	35.0	29	1.0
Pinion 4	[-]	3	10.00	14	49.182	32	52.36	44.563	46.363	83.0	67.0	38.0	29	1.2

m_n : Normal module, P_t : Transverse pitch [mm], z : Number of teeth, D_0 : Pitch circle diameter for calculation, D_v : Pitch circle diameter for design, M: Weight [kg]

Available ratios	i		I-stage						
			3	4	5	7	10		
Nominal torque S5 ^{a)}	T _{2N}	[Nm]	200	260	270	250	150		
Acceleration torque S5 ^{b)}	T _{2B}	[Nm]	320	350	350	330	265		
Nominal input speed S5 ^{c)}	n _{1N}	[rpm]	1 300	2 300	2 600	2 600	2 600		
Maximum input speed S5	n _{1max}	[rpm]	1 700	4 500	4 500	4 500	4 500		
Nominal torque S1 ^{a)}	T _{2N}	[Nm]	–	175	175	175	115		
Acceleration torque S1 ^{b)}	T _{2B}	[Nm]	–	250	250	250	190		
Nominal input speed S1 ^{c)}	n _{1N}	[rpm]	–	1 500	1 600	1 800	1 800		
Maximum input speed S1	n _{1max}	[rpm]	–	2 000	2 000	2 800	2 800		
Emergency stop torque ^{d)}	T _{2not}	[Nm]	500	630	630	630	630		
Efficiency	η	[%]	97						
Lifetime	L _h	[h]	> 20 000						
Weight	M	[kg]	9						
Angular backlash	i _c	[arcmin]	Precision P 1 ≤ 1 / P 3 ≤ 3 / P 5 ≤ 5						
Tilting moment	M _{kmax}	[Nm]	614						
Torsionnal rigidity ^{e)}	C _{t2}	[Nm/arcmin]	78	82	88	78	64		
Tilting rigidity ^{e)}	C _{t2}	[Nm/arcmin]	458						
Noise ⁱ⁾	L _{pA}	[dB(A)]	< 62						
Max. permitted housing temperature ^{g)}	T	[°C]	90						
Protection class			IP 65						
Direction of rotation			Same way input / output						
Max. axial force on output shaft ^{f)}	F _{amax}	[N]	4 800						
Color			Red, RAL 3003						
Inertia in kg.cm ² ^{h)}	Ø	J ₁	[kgcm ²]	Ø 11	6.134	3.95	3.072	2.337	1.948
				Ø 14	6.114	3.93	3.052	2.317	1.928
				Ø 19	6.874	4.69	3.812	3.077	2.688
				Ø 24	7.194	5.01	4.132	3.397	3.008
				Ø 32	8.234	6.05	5.172	4.437	4.048
				Ø 35	14.364	12.18	11.302	10.567	10.178
				Ø 38	14.334	12.15	11.272	10.537	10.148

- a) Nominal output torque when operating at n_{1N}.
- b) 1000 cycles per hour max.
- c) Valid for an ambient temperature of 20°C and T_{2N}.
At higher ambient temperatures, please reduce speed.
- d) Valid 1000 times the gear box life.

- e) Valid for an input Ø of 24 mm in 1-stage and 19 mm in 2-stage.
- f) Values for 300 rpm.
- g) For other temperatures, please contact us. Nominal output torque when operating at n_{1N}.
- h) Depending on the motor output shaft Ø.
- i) With i=10 and n_{1N}=3000 rpm no load.

Rack



			Pinion 1			Pinion 2			Pinion 3			Pinion 4		
			Q6	Q7	Q9	Q6	Q7	Q9	Q6	Q7	Q9	Q6	Q7	Q9
Max acceleration force	F _{2B}	[N]	7 075	1 760	4 752	7 505	3 217	5 016	10 570	2 813	7 620	15 076	3 661	11 052
Max acceleration torque	T _{2B}	[Nm]	120	30	81	167	72	112	224	60	162	336	82	246
Precision			P1 P5			P1 P5			P1 P5			P1 P5		
Feed force			High	Medium	Elevated	High	Medium	Elevated	High	Medium	Elevated	High	Medium	Elevated

For proper sizing follow flowchart calculate your ideal drive train on pages 136 et seq.

More on the technical datasheets your ideal drive train on pages 120 et seq.

Above values for rack and pinion take into consideration a number of load cycles: 1x10⁶ for the rack; 1x10⁷ for the pinion. Both in pulsating operation.

Input

A	for motor shaft	$L \leq 54$	$\varnothing d \leq 24$	result in LA
B	for motor shaft	$54 < L \leq 65$	$\varnothing d \leq 38$	result in LB
C	for motor shaft	$65 < L \leq 80$	$\varnothing d \leq 38$	result in LC



		1-stage	2-stage
LA	[mm]	132.1	183.1
LB	[mm]	143.1	194.1
LC	[mm]	163.1	214.1

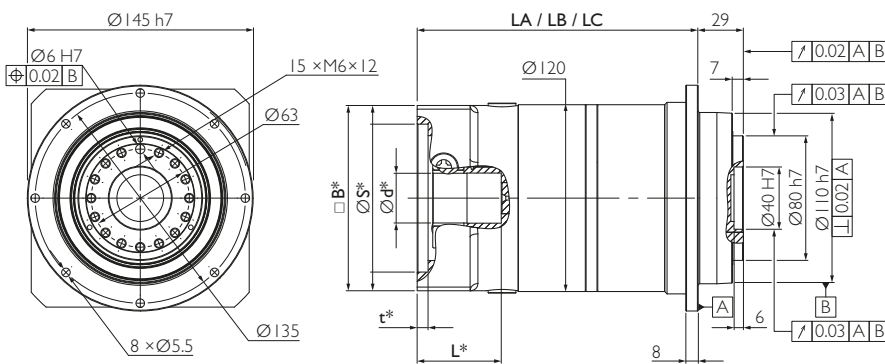

* depending on the motor. See pages 130 et seq.

Example NRHP 100 A0, 2-stage



Your ideal drive train

Function Package with gearbox, rack and pinion from Güdel

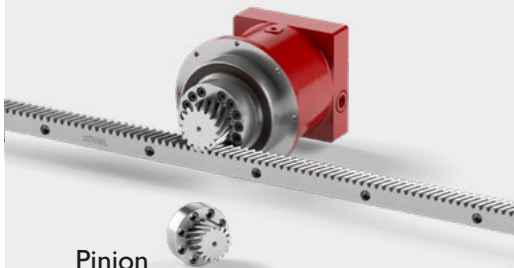

Pinion

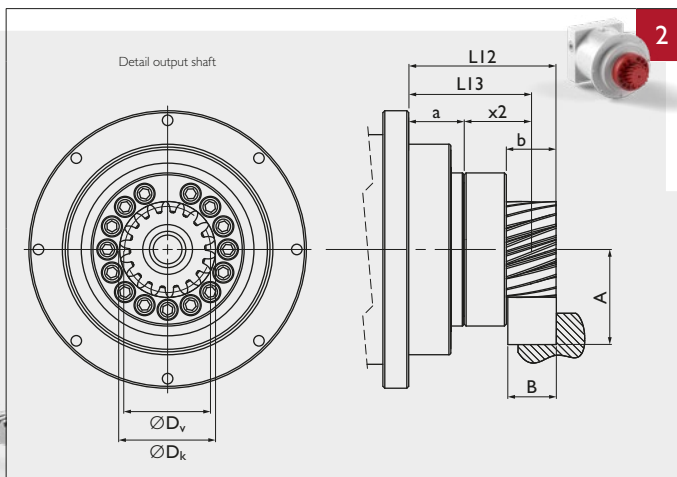

Material 16MnCr5
DIN 1.7131
Teeth pressure angle $\alpha = 20^\circ$,
helical teeth left,
 $19^\circ 31' 42''$,
hardened (58^{+1} HRC),
ground, crowned
Quality 6f24 DIN 3962 / 63 / 67

	m_n	P_t	z	A	b	D_k	D_0	D_v	L12	L13	x2	a	M	
Pinion 1	[-]	2	6.66	16	39.577	26	39.15	33.953	35.153	77.0	64.0	35.0	29	1.0
Pinion 2	[-]	2	6.66	21	44.282	26	48.56	44.563	44.563	77.0	64.0	35.0	29	1.0
Pinion 3	[-]	2.5	8.33	16	43.471	26	48.94	42.441	43.941	77.0	64.0	35.0	29	1.0
Pinion 4	[-]	3	10.00	14	49.182	32	52.36	44.563	46.363	83.0	67.0	38.0	29	1.2

m_n : Normal module, P_t : Transverse pitch [mm], z : Number of teeth, D_0 : Pitch circle diameter for calculation, D_v : Pitch circle diameter for design, M: Weight [kg]

Available ratios *	i		2-stage											
			12	16	20	25	30	35	40	50	70	100		
Nominal torque S5 ^{a)}	T _{2N}	[Nm]	200	260	270	270	200	270	260	270	250	150		
Acceleration torque S5 ^{b)}	T _{2B}	[Nm]	320	350	350	350	320	350	350	320	330	265		
Nominal input speed S5 ^{c)}	n _{1N}	[rpm]	2 400	2 900	2 900	2 900	2 900	2 900	2 900	3 200	3 600	4 300		
Maximum input speed S5	n _{1max}	[rpm]	5 000	6 000	6 000	6 000	6 000	6 000	6 000	6 000	6 000	6 000		
Nominal torque S1 ^{a)}	T _{2N}	[Nm]	175	175	175	175	175	175	175	175	175	115		
Acceleration torque S1 ^{b)}	T _{2B}	[Nm]	250	250	250	250	250	250	250	250	250	190		
Nominal input speed S1 ^{c)}	n _{1N}	[rpm]	2 000	2 000	2 000	2 000	2 000	2 000	2 000	2 000	2 000	2 500		
Maximum input speed S1	n _{1max}	[rpm]	3 000	3 100	3 100	3 100	3 100	3 100	3 100	3 100	3 500	4 000		
Emergency stop torque ^{d)}	T _{2not}	[Nm]	630	630	630	630	630	630	630	630	630	630		
Efficiency	η	[%]	94											
Lifetime	L _h	[h]	> 20 000											
Weight	M	[kg]	12.5											
Angular backlash	i _c	[arcmin]	Precision P 1 ≤ 1 / P 3 ≤ 3 / P 5 ≤ 5											
Tilting moment	M _{kmax}	[Nm]	614											
Torsionnal rigidity ^{e)}	C _{t2}	[Nm/arcmin]	78	81	87	87	87	87	81	87	77	64		
Tilting rigidity ^{e)}	C _{t2}	[Nm/arcmin]	458											
Noise ⁱ⁾	L _{pA}	[dB(A)]	< 62											
Max. permitted housing temperature ^{g)}	T	[°C]	90											
Protection class			IP 65											
Direction of rotation			Same way input / output											
Max. axial force on output shaft ^{f)}	F _{amax}	[N]	4 800											
Color			Red, RAL 3003											
Inertia in kg.cm ² ^{h)}	Ø	J ₁	[kgcm ²]	Ø11	3.033	2.896	2.841	2.363	1.802	1.976	1.78	1.771	1.764	1.76
				Ø14	3.013	2.876	2.821	2.343	1.782	1.956	1.76	1.751	1.744	1.74
				Ø19	3.773	3.636	3.581	3.103	2.542	2.716	2.52	2.511	2.504	2.5
				Ø24	4.093	3.956	3.901	3.423	2.862	3.036	2.84	2.831	2.824	2.82
				Ø32	5.133	4.996	4.941	4.463	3.902	4.076	3.88	3.871	3.864	3.86
				Ø35	11.263	11.126	11.071	10.593	10.032	10.206	10.01	10.001	9.994	9.99
				Ø38	11.233	11.096	11.041	10.563	10.002	10.176	9.98	9.971	9.964	9.96

* Other ratios available. 9, 15, 21, 27, 28, 49 on request.

- a) Nominal output torque when operating at n_{1N}.
- b) 1000 cycles per hour max.
- c) Valid for an ambient temperature of 20°C and T_{2N}. At higher ambient temperatures, please reduce speed.
- d) Valid 1000 times the gearbox life.

- e) Valid for an input Ø of 24 mm in 1-stage and 19 mm in 2-stage.
- f) Values for 300 rpm.
- g) For other temperatures, please contact us. Nominal output torque when operating at n_{1N}.
- h) Depending on the motor output shaft Ø.
- i) With i=10 and n_{1N}=3000 rpm no load.

Rack



			Pinion 1			Pinion 2			Pinion 3			Pinion 4		
			Q6	Q7	Q9	Q6	Q7	Q9	Q6	Q7	Q9	Q6	Q7	Q9
Max acceleration force	F _{2B}	[N]	7 075	1 760	4 752	7 505	3 217	5 016	10 570	2 813	7 620	15 076	3 661	11 052
Max acceleration torque	T _{2B}	[Nm]	120	30	81	167	72	112	224	60	162	336	82	246
Precision			P1		P5	P1		P5	P1		P5	P1		P5
Feed force			High	Medium	Elevated	High	Medium	Elevated	High	Medium	Elevated	High	Medium	Elevated

For proper sizing follow flowchart calculate your ideal drive train on pages 136 et seq.

More on the technical datasheets your ideal drive train on pages 120 et seq.

Above values for rack and pinion take into consideration a number of load cycles: 1x10⁶ for the rack; 1x10⁷ for the pinion. Both in pulsating operation.

Input

A	for motor shaft	$L \leq 62$	$\varnothing d \leq 38$	result in LA
B	for motor shaft	$62 < L \leq 115$	$\varnothing d \leq 48$	result in LB

Output



		I-stage	2-stage
LA	[mm]	156.5	189.5
LB	[mm]	208.5	200.5
LC	[mm]		220.5

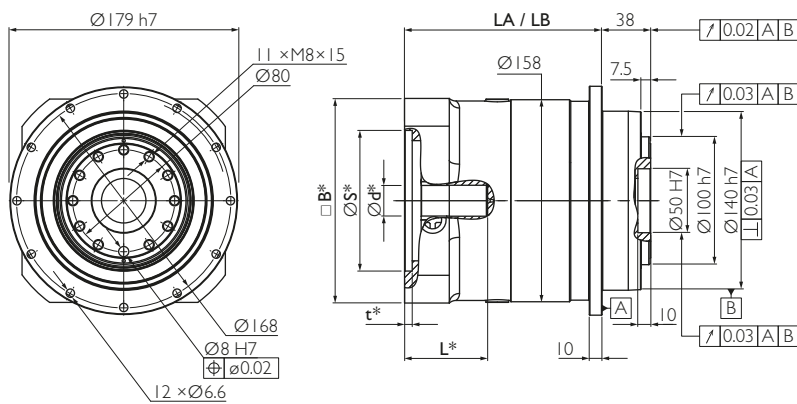

* depending on the motor. See pages 130 et seq.



Example NRHP 140 A0, I-stage

Your ideal drive train

Function Package with gearbox, rack and pinion from Güdel

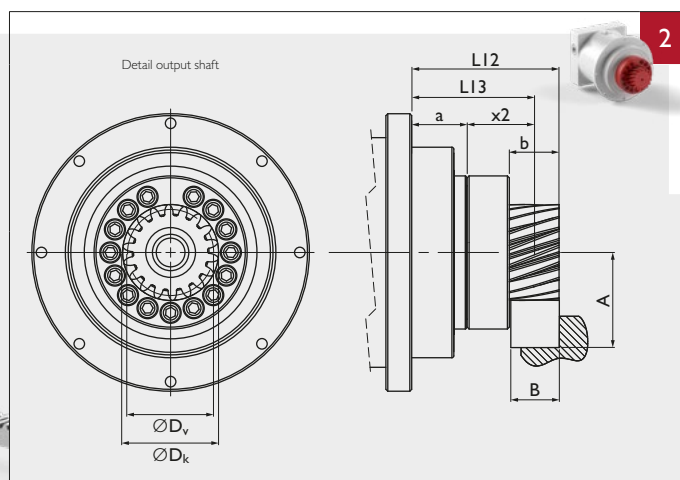
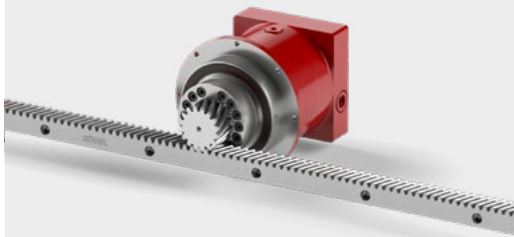

Material 16MnCr5
DIN 1.7131
Teeth pressure angle $\alpha = 20^\circ$,
helical teeth left,
 $19^\circ 31' 42''$,
hardened (58^{+1} HRC),
ground, crowned
Quality 6f24 DIN 3962 / 63 / 67

Pinion

	m_n	P_t	z	A	b	D_k	D_0	D_v	L12	L13	x2	a	M	
Pinion 1	[-]	2.5	8.33	21	49.352	26	60.70	55.704	55.704	89.0	76.0	38.0	38	1.9
Pinion 2	[-]	3	10.00	18	54.648	32	63.30	57.296	57.296	95.0	79.0	41.0	38	2.0

m_n : Normal module, P_t : Transverse pitch [mm], z : Number of teeth, D_0 : Pitch circle diameter for calculation, D_v : Pitch circle diameter for design, M: Weight [kg]

Available ratios	i		I-stage						
			3	4	5	7	10		
Nominal torque S5 ^{a)}	T _{2N}	[Nm]	400	490	500	470	310		
Acceleration torque S5 ^{b)}	T _{2B}	[Nm]	520	650	650	650	500		
Nominal input speed S5 ^{c)}	n _{1N}	[rpm]	1 500	1 900	2 100	2 500	2 600		
Maximum input speed S5	n _{1max}	[rpm]	2 500	4 000	4 000	4 000	4 000		
Nominal torque S1 ^{a)}	T _{2N}	[Nm]	–	260	260	260	130		
Acceleration torque S1 ^{b)}	T _{2B}	[Nm]	–	370	370	370	220		
Nominal input speed S1 ^{c)}	n _{1N}	[rpm]	–	900	1 000	1 200	1 200		
Maximum input speed S1	n _{1max}	[rpm]	–	1 600	1 600	2 600	2 600		
Emergency stop torque ^{d)}	T _{2not}	[Nm]	1 300	1 300	1 300	1 300	1 260		
Efficiency	η	[%]	97						
Lifetime	L _h	[h]	> 20 000						
Weight	M	[kg]	17						
Angular backlash	i _c	[arcmin]	Precision P 1 ≤ 1 / P 3 ≤ 3 / P 5 ≤ 5						
Tilting moment	M _{kmax}	[Nm]	1 400						
Torsionnal rigidity ^{e)}	C _{t2}	[Nm/arcmin]	180	195	193	164	128		
Tilting rigidity ^{e)}	C _{t2}	[Nm/arcmin]	934						
Noise ⁱ⁾	L _{pA}	[dB(A)]	< 62						
Max. permitted housing temperature ^{g)}	T	[°C]	90						
Protection class			IP 65						
Direction of rotation			Same way input / output						
Max. axial force on output shaft ^{f)}	F _{amax}	[N]	7 600						
Color			Red, RAL 3003						
Inertia in kg.cm ² ^{h)}	Ø	J ₁	[kg.cm ²]	Ø19	16.069	9.704	7.173	5.003	3.881
				Ø24	16.389	10.024	7.493	5.323	4.201
				Ø32	22.249	15.884	13.353	11.183	10.061
				Ø35	22.839	16.474	13.943	11.773	10.651
				Ø38	23.309	16.944	14.413	12.243	11.121
				Ø42	23.639	17.274	14.743	12.573	11.451
				Ø48	27.619	21.254	18.723	16.553	15.431

- a) Nominal output torque when operating at n_{1N}.
- b) 1 000 cycles per hour max.
- c) Valid for an ambient temperature of 20°C and T_{2N}.
At higher ambient temperatures, please reduce speed.
- d) Valid 1 000 times the gear box life.

- e) Valid for an input Ø of 38 mm in 1-stage and 24 mm in 2-stage.
- f) Values for 300 rpm.
- g) For other temperatures, please contact us. Nominal output torque when operating at n_{1N}.
- h) Depending on the motor output shaft Ø.
- i) With i=10 and n_{1N}=3000 rpm no load.

Rack



			Pinion 1			Pinion 2		
			Q6	Q7	Q9	Q6	Q7	Q9
Max acceleration force	F _{2B}	[N]	11 216	5 197	8 053	15 790	6 350	12 686
Max acceleration torque	T _{2B}	[Nm]	312	145	224	452	182	363
Precision			PI		P5	PI		P5
Feed force			High	Medium	Elevated	High	Medium	Elevated

For proper sizing follow flowchart
calculate your ideal drive train
on pages 136 et seq.

More on the technical datasheets
your ideal drive train on pages
120 et seq.

Above values for rack and pinion take into consideration a number of load cycles:
1x10⁶ for the rack; 1x10⁷ for the pinion. Both in pulsating operation.

Input

A	for motor shaft	$L \leq 54$	$\varnothing d \leq 32$	result in LA
B	for motor shaft	$54 < L \leq 65$	$\varnothing d \leq 38$	result in LB
C	for motor shaft	$65 < L \leq 80$	$\varnothing d \leq 38$	result in LC



		1-stage	2-stage
LA	[mm]	156.5	189.5
LB	[mm]	208.5	200.5
LC	[mm]		220.5

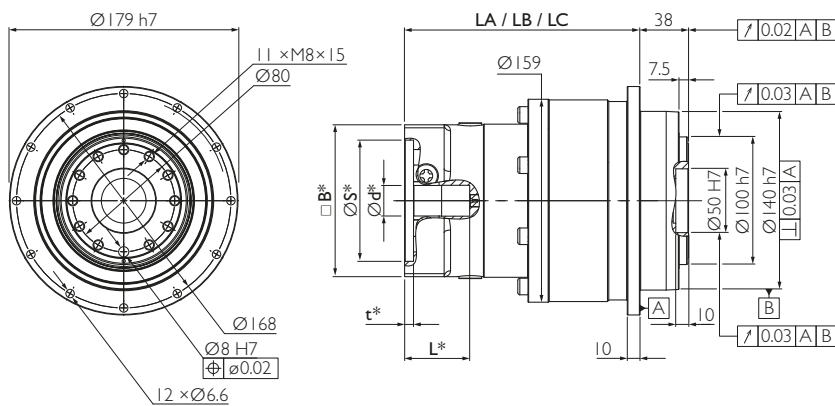

* depending on the motor. See pages 130 et seq.



Example NRHP 140 A0, 2-stage

Your ideal drive train

Function Package with gearbox, rack and pinion from Güdel

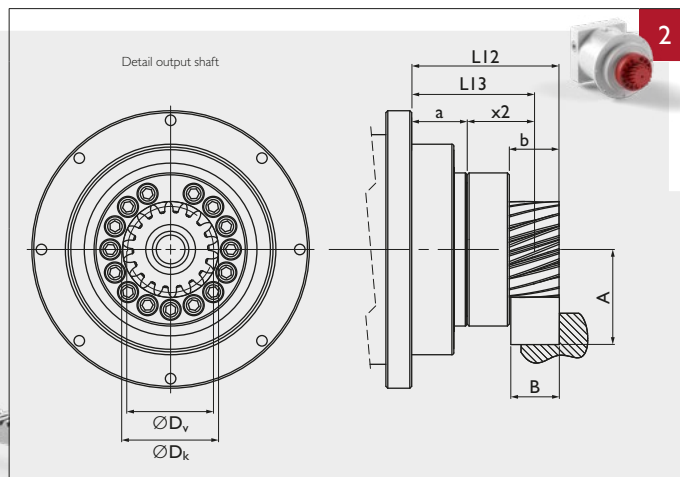
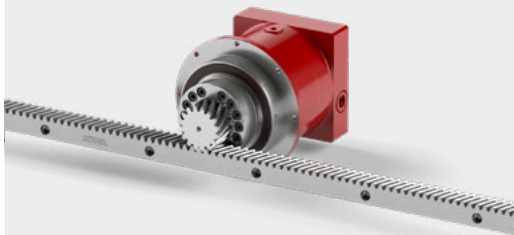

Material 16MnCr5
DIN 1.7131
Teeth pressure angle $\alpha = 20^\circ$,
helical teeth left,
 $19^\circ 31' 42''$,
hardened (58^{+1} HRC),
ground, crowned
Quality 6f24 DIN 3962 / 63 / 67

Pinion

	m_n	P_t	z	A	b	D_k	D_0	D_v	L12	L13	x2	a	M	
Pinion 1	[-]	2.5	8.33	21	49.352	26	60.70	55.704	55.704	89.0	76.0	38.0	38	1.9
Pinion 2	[-]	3	10.00	18	54.648	32	63.30	57.296	57.296	95.0	79.0	41.0	38	2.0

m_n : Normal module, P_t : Transverse pitch [mm], z : Number of teeth, D_0 : Pitch circle diameter for calculation, D_v : Pitch circle diameter for design, M: Weight [kg]

Available ratios *	i		2-stage										
			12	16	20	25	30	35	40	50	70	100	
Nominal torque S5 ^{a)}	T _{2N}	[Nm]	400	490	500	500	400	500	490	500	470	310	
Acceleration torque S5 ^{b)}	T _{2B}	[Nm]	520	650	650	650	600	650	650	650	650	500	
Nominal input speed S5 ^{c)}	n _{1N}	[rpm]	2 900	2 900	2 900	3 000	3 000	3 000	3 000	3 300	3 300	4 000	
Maximum input speed S5	n _{1max}	[rpm]	4 200	4 200	4 200	5 000	5 000	5 000	5 000	5 000	5 000	5 000	
Nominal torque S1 ^{a)}	T _{2N}	[Nm]	260	260	260	260	260	260	260	260	260	150	
Acceleration torque S1 ^{b)}	T _{2B}	[Nm]	370	370	370	370	370	370	370	370	370	220	
Nominal input speed S1 ^{c)}	n _{1N}	[rpm]	1 400	1 400	1 800	1 800	2 000	2 000	2 000	2 000	2 200	2 200	
Maximum input speed S1	n _{1max}	[rpm]	2 700	2 900	2 800	2 800	2 800	2 800	2 800	3 000	3 000	3 200	
Emergency stop torque ^{d)}	T _{2not}	[Nm]	1 300	1 300	1 300	1 300	1 300	1 300	1 300	1 300	1 300	1 260	
Efficiency	η	[%]	94										
Lifetime	L _h	[h]	> 20 000										
Weight	M	[kg]	20										
Angular backlash	i _c	[arcmin]	Precision P 1 ≤ 1 / P 3 ≤ 3 / P 5 ≤ 5										
Tilting moment	M _{kmax}	[Nm]	1 400										
Torsionnal rigidity ^{e)}	C _{t2}	[Nm/arcmin]	170	185	185	183	160	183	177	178	147	117	
Tilting rigidity ^{e)}	C _{t2}	[Nm/arcmin]	934										
Noise ⁱ⁾	L _{pA}	[dB(A)]	< 62										
Max. permitted housing temperature ^{g)}	T	[°C]	90										
Protection class			IP 65										
Direction of rotation			Same way input / output										
Max. axial force on output shaft ^{f)}	F _{amax}	[N]	7 600										
Color			Red, RAL 3003										
Inertia in kg.cm ² ^{h)}	Ø14	J ₁	[kgcm ²]	3.556	3.158	3	2.457	1.869	2.014	1.805	1.78	1.758	1.747
	Ø19			4.316	3.918	3.76	3.217	2.629	2.774	2.565	2.54	2.518	2.507
	Ø24			4.636	4.238	4.08	3.537	2.949	3.094	2.885	2.86	2.838	2.827
	Ø32			5.676	5.278	5.12	4.577	3.989	4.134	3.925	3.9	3.878	3.867
	Ø35			11.806	11.408	11.25	10.707	10.119	10.264	10.055	10.03	10.008	9.997
	Ø38			11.776	11.378	11.22	10.677	10.089	10.234	10.025	10	9.978	9.967

* Other ratios available. 9, 15, 21, 27, 28, 49 on request.

a) Nominal output torque when operating at n_{1N}.

b) 1 000 cycles per hour max.

c) Valid for an ambient temperature of 20°C and T_{2N}.
At higher ambient temperatures, please reduce speed.

d) Valid 1 000 times the gear box life.

e) Valid for an input Ø of 24 mm in 1-stage and 19 mm in 2-stage.

f) Values for 300 rpm.

g) For other temperatures, please contact us. Nominal output torque when operating at n_{1N}.

h) Depending on the motor output shaft Ø.

i) With i=10 and n_{1N}=3000 rpm no load.

Rack



			Pinion 1			Pinion 2		
			Q6	Q7	Q9	Q6	Q7	Q9
Max acceleration force	F _{2B}	[N]	11 216	5 197	8 053	15 790	6 350	12 686
Max acceleration torque	T _{2B}	[Nm]	312	145	224	452	182	363
Precision			PI		P5	PI		P5
Feed force			High	Medium	Elevated	High	Medium	Elevated

For proper sizing follow flowchart
calculate your ideal drive train
on pages 136 et seq.

More on the technical datasheets
your ideal drive train on pages
120 et seq.

Above values for rack and pinion take into consideration a number of load cycles:
1x10⁶ for the rack; 1x10⁷ for the pinion. Both in pulsating operation.

Input

A	for motor shaft	$L \leq 50$	$\varnothing d \leq 19$	result in LA
B	for motor shaft	$50 < L \leq 55$	$\varnothing d \leq 24$	result in LB
C	for motor shaft	$55 < L \leq 60$	$\varnothing d \leq 24$	result in LC

		I-stage	2-stage
LA	[mm]	108	145
LB	[mm]	116	153
LC	[mm]	121	158

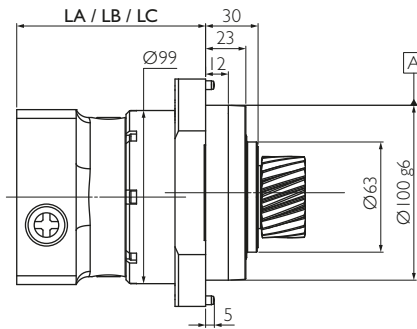
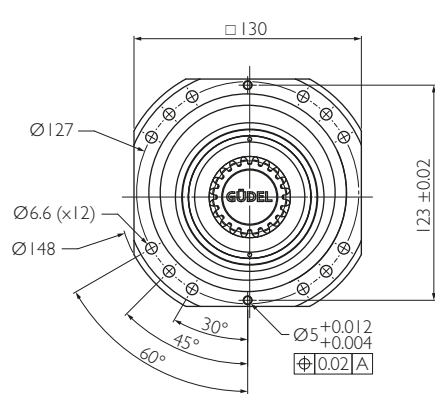

Output

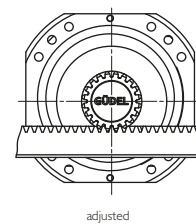
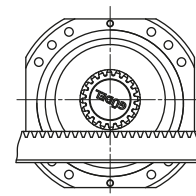

The drawings show the two positions for assembling and operating.



Example NGHP 080 A2, 1-stage

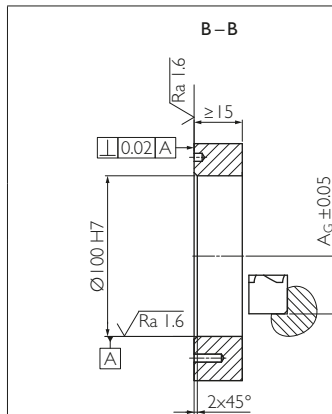

Customer interface

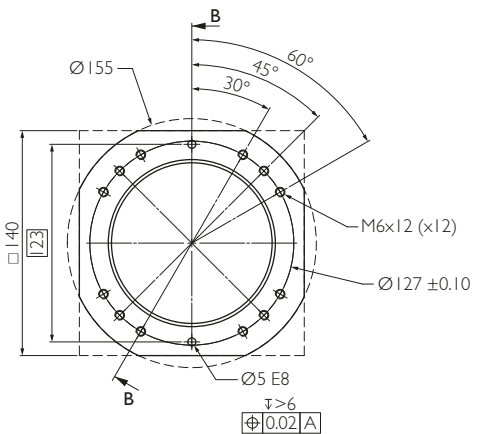

Your ideal drive train

Function Package with gearbox, rack and pinion from Güdel

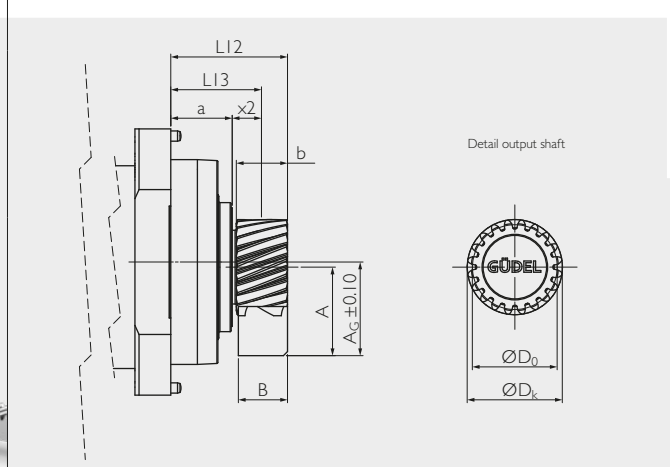
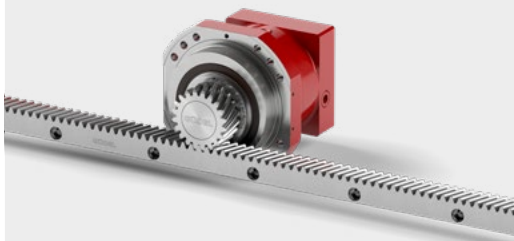

Detail output shaft

Material 16MnCr5
DIN 1.7131
Teeth pressure angle $\alpha = 20^\circ$,
helical teeth left,
 $19^\circ 31' 42''$,
hardened (58^{+1} HRC),
ground, crowned
Quality 6f24 DIN 3962 / 63 / 67

Pinion



	m_n	P_t	z	A	A_G	b	D_k	D_0	D_v	L12	L13	x2	a	M	
Pinion 1	[-]	2	6.66	20	43.221	45.721	25	46.44	42.441	42.441	57.0	44.5	14.5	30	0.3
Pinion 2	[-]	2.5	8.33	16	43.471	45.971	25	48.94	42.441	43.941	57.0	44.5	14.5	30	0.3

m_n : Normal module, P_t : Transverse pitch [mm], z : Number of teeth, A_G : Gearbox position, D_0 : Pitch circle diameter for calculation, D_v : Pitch circle diameter for design, M: Weight [kg]

Available ratios	i		I-stage					
			3	4	5	7	10	
Nominal torque S5 ^{a)}	T _{2N}	[Nm]	65	75	76	76	60	
Acceleration torque S5 ^{b)}	T _{2B}	[Nm]	85	110	110	110	90	
Nominal input speed S5 ^{c)}	n _{1N}	[rpm]	2 300	2 300	2 900	3 100	3 100	
Maximum input speed S5	n _{1max}	[rpm]	4 000	5 000	6 000	6 000	6 000	
Nominal torque S1 ^{a)}	T _{2N}	[Nm]	–	50	50	50	35	
Acceleration torque S1 ^{b)}	T _{2B}	[Nm]	–	72	72	72	44	
Nominal input speed S1 ^{c)}	n _{1N}	[rpm]	–	2 000	2 000	2 200	2 200	
Maximum input speed S1	n _{1max}	[rpm]	–	2 900	2 900	3 100	3 100	
Emergency stop torque ^{d)}	T _{2not}	[Nm]	250	250	250	250	200	
Efficiency	η	[%]	97					
Lifetime	L _h	[h]	> 20 000					
Weight	M	[kg]	4.9					
Angular backlash	j _c	[arcmin]	Precision P 1 ≤ 1 / P 3 ≤ 3 / P 5 ≤ 5					
Tilting moment	M _{kmax}	[Nm]	348					
Torsionnal rigidity ^{e)}	C _{t2}	[Nm/arcmin]	32	38	40	36	28	
Tilting rigidity ^{e)}	C _{t2}	[Nm/arcmin]	252					
Noise ⁱ⁾	L _{pA}	[dB(A)]	< 62					
Max. permitted housing temperature ^{g)}	T	[°C]	90					
Protection class			IP 65					
Direction of rotation			Same way input / output					
Max. axial force on output shaft ^{f)}	F _{amax}	[N]	2 300					
Color			Red, RAL 3003					
Inertia in kg.cm ² ^{h)}	Ø 11	J ₁	[kgcm ²]	1.897	1.327	1.083	0.871	0.759
	Ø 14			1.887	1.317	1.073	0.861	0.749
	Ø 19			2.65	2.08	1.836	1.624	1.512
	Ø 24			2.978	2.408	2.164	1.952	1.84

- a) Nominal output torque when operating at n_{1N}.
- b) 1000 cycles per hour max.
- c) Valid for an ambient temperature of 20°C and T_{2N}.
At higher ambient temperatures, please reduce speed.
- d) Valid 1000 times the gearbox life.

- e) Valid for an Input Ø of 19 mm in I-stage and 14 mm in 2-stage.
- f) Values for 300 rpm / 20000 h.
- g) For other temperatures, please contact us. Nominal output torque when operating at n_{1N}.
- h) Depending on the motor output shaft Ø.
- i) With i=10 and n_{1N}=3000 rpm no load.

Rack



			Pinion 1			Pinion 2		
			Q6	Q7	Q9	Q6	Q7	Q9
Max acceleration force	F _{2B}	[N]	7 075	1 760	4 752	10 570	2 813	7 620
Max acceleration torque	T _{2B}	[Nm]	120	30	81	224	60	162
Precision			PI		P5	PI		P5
Feed force			High	Medium	Elevated	High	Medium	Elevated

Above values for rack and pinion take into consideration a number of load cycles: 1x10⁶ for the rack; 1x10⁷ for the pinion. Both in pulsating operation.

For proper sizing follow flowchart **calculate your ideal drive train** on pages 136 et seq.

More on the technical datasheets **your ideal drive train** on pages 120 et seq.

Input

A	for motor shaft	$L \leq 50$	$\varnothing d \leq 19$	result in LA
B	for motor shaft	$50 < L \leq 55$	$\varnothing d \leq 24$	result in LB
C	for motor shaft	$55 < L \leq 60$	$\varnothing d \leq 24$	result in LC

		1-stage	2-stage
LA	[mm]	108	145
LB	[mm]	116	153
LC	[mm]	121	158

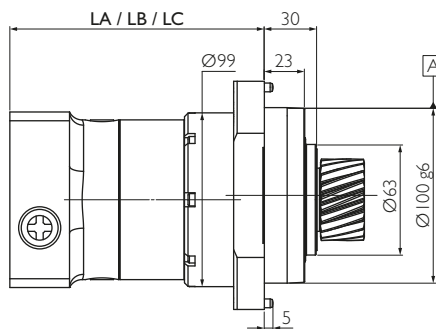
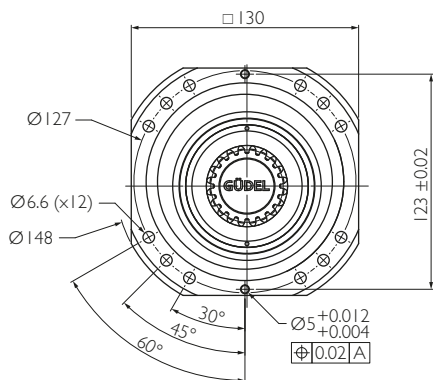

Output

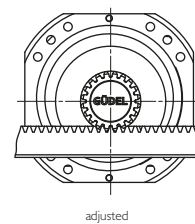
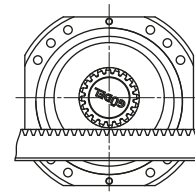

The drawings show the two positions for assembling and operating.



Example NGHP 080 A2, 1-stage

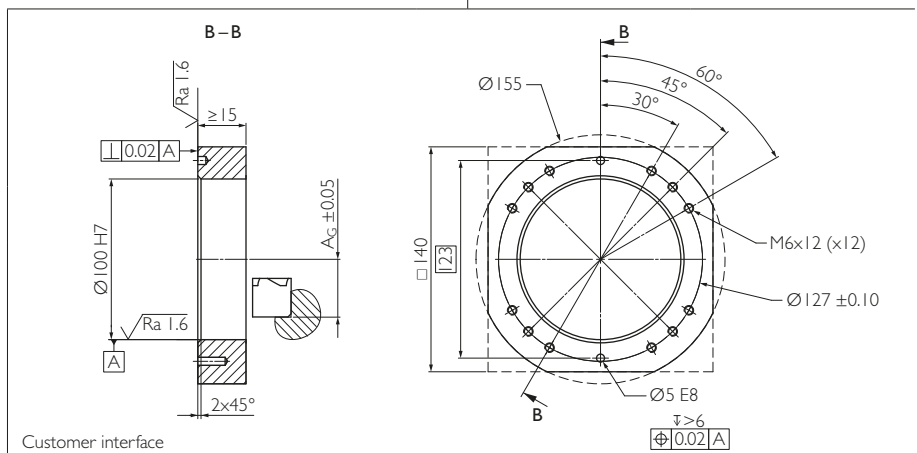

Customer interface

Your ideal drive train

Function Package with gearbox, rack and pinion from Güdel

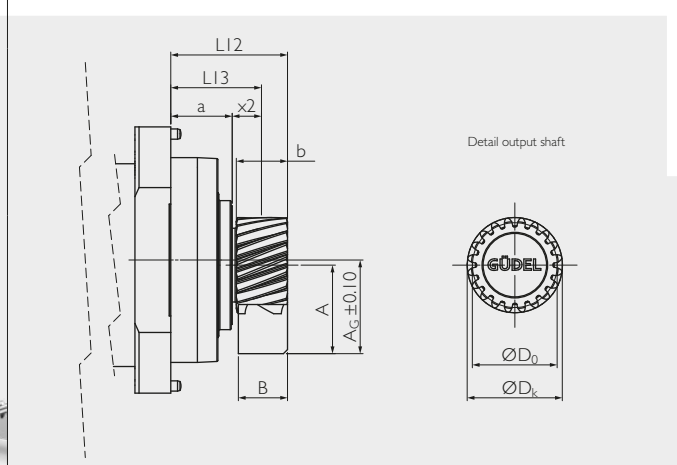
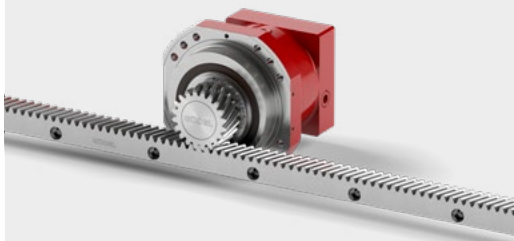

Detail output shaft

Material 16MnCr5
DIN 1.7131
Teeth pressure angle $\alpha = 20^\circ$,
helical teeth left,
19°31'42";
hardened (58⁺¹ HRC),
ground, crowned
Quality 6f24 DIN 3962 / 63 / 67

Pinion



	m_n	P_t	z	A	A_G	b	D_k	D_0	D_v	L12	L13	x2	a	M	
Pinion 1	[-]	2	6.66	20	43.221	45.721	25	46.44	42.441	42.441	57.0	44.5	14.5	30	0.3
Pinion 2	[-]	2.5	8.33	16	43.471	45.971	25	48.94	42.441	43.941	57.0	44.5	14.5	30	0.3

m_n : Normal module, P_t : Transverse pitch [mm], z : Number of teeth, A_G : Gearbox position, D_0 : Pitch circle diameter for calculation, D_v : Pitch circle diameter for design, M: Weight [kg]

Available ratios *	i		2-stage										
			12	16	20	25	30	35	40	50	70	100	
Nominal torque S5 ^{a)}	T _{2N}	[Nm]	75	90	90	90	75	90	90	90	90	60	
Acceleration torque S5 ^{b)}	T _{2B}	[Nm]	85	110	110	110	90	110	110	110	110	90	
Nominal input speed S5 ^{c)}	n _{1N}	[rpm]	3 600	3 600	3 600	3 600	3 600	3 500	3 500	3 800	4 500	4 500	
Maximum input speed S5	n _{1max}	[rpm]	6 000	6 000	6 000	6 000	6 000	6 000	6 000	6 000	6 000	6 000	
Nominal torque S1 ^{a)}	T _{2N}	[Nm]	50	50	50	50	40	50	50	50	50	35	
Acceleration torque S1 ^{b)}	T _{2B}	[Nm]	72	72	72	72	72	72	72	72	72	47	
Nominal input speed S1 ^{c)}	n _{1N}	[rpm]	2 300	2 500	2 500	2 500	2 500	2 500	2 500	3 000	2 800	3 100	
Maximum input speed S1	n _{1max}	[rpm]	3 300	3 500	3 500	3 500	3 500	3 500	3 500	3 800	4 000	4 500	
Emergency stop torque ^{d)}	T _{2not}	[Nm]	250	250	250	250	250	250	250	250	250	200	
Efficiency	η	[%]	94										
Lifetime	L _h	[h]	> 20 000										
Weight	M	[kg]	6.5										
Angular backlash	j _c	[arcmin]	Precision P 1 ≤ 1 / P 3 ≤ 3 / P 5 ≤ 5										
Tilting moment	M _{kmax}	[Nm]	348										
Torsionnal rigidity ^{e)}	C _{t2}	[Nm/arcmin]	32	38	38	39	32	39	35	36	34	27	
Tilting rigidity ^{e)}	C _{t2}	[Nm/arcmin]	252										
Noise ⁱ⁾	L _{pA}	[dB(A)]	< 62										
Max. permitted housing temperature ^{g)}	T	[°C]	90										
Protection class			IP 65										
Direction of rotation			Same way input / output										
Max. axial force on output shaft ^{f)}	F _{amax}	[N]	2 300										
Color			Red, RAL 3003										
Inertia in kg.cm ² ^{h)}	Ø 11	J ₁	[kgcm ²]	0.937	0.937	0.886	0.8	0.693	0.727	0.688	0.685	0.683	0.6559
	Ø 14			0.927	0.927	0.876	0.79	0.683	0.717	0.678	0.675	0.673	0.6459
	Ø 19			1.69	1.69	1.639	1.553	1.446	1.48	1.441	1.438	1.436	1.4089
	Ø 24			2.018	2.018	1.967	1.881	1.774	1.808	1.769	1.766	1.764	1.7369

- * Other ratios available. 9, 15, 21, 27, 28, 49 on request.
- a) Nominal output torque when operating at n_{1N}.
- b) 1000 cycles per hour max.
- c) Valid for an ambient temperature of 20°C and T_{2N}.
At higher ambient temperatures, please reduce speed.
- d) Valid 1000 times the gearbox life.

- e) Valid for an Input Ø of 19 mm in 1-stage and 14 mm in 2-stage.
- f) Values for 300 rpm / 20000 h.
- g) For other temperatures, please contact us. Nominal output torque when operating at n_{1N}.
- h) Depending on the motor output shaft Ø.
- i) With i=10 and n_{1N}=3000 rpm no load.

Rack



			Pinion 1			Pinion 2		
			Q6	Q7	Q9	Q6	Q7	Q9
Max acceleration force	F _{2B}	[N]	7 075	1 760	4 752	10 570	2 813	7620
Max acceleration torque	T _{2B}	[Nm]	120	30	81	224	60	162
Precision			PI		P5	PI		P5
Feed force			High	Medium	Elevated	High	Medium	Elevated

Above values for rack and pinion take into consideration a number of load cycles: 1x10⁶ for the rack; 1x10⁷ for the pinion. Both in pulsating operation.

For proper sizing follow flowchart calculate your ideal drive train on pages 136 et seq.

More on the technical datasheets your ideal drive train on pages 120 et seq.

Input

A	for motor shaft	$L \leq 54$	$\varnothing d \leq 24$	result in LA
B	for motor shaft	$54 < L \leq 65$	$\varnothing d \leq 38$	result in LB
C	for motor shaft	$65 < L \leq 80$	$\varnothing d \leq 38$	result in LC

		I-stage	2-stage
LA	[mm]	132.1	183.1
LB	[mm]	143.1	194.1
LC	[mm]	163.1	214.1

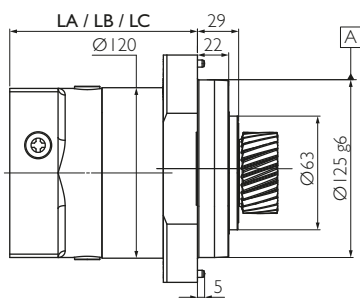
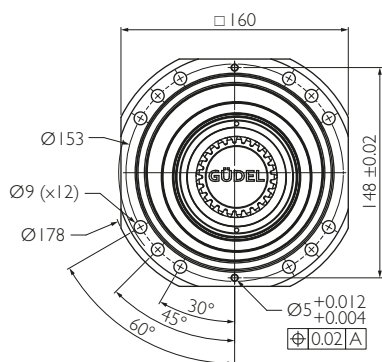

Output



GAdjustment



gudel.com/gadjustment

Manual



gudel.com/manual/planetary-gearbox

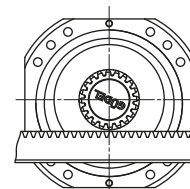

disengaged

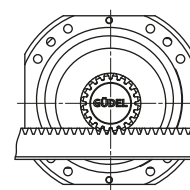

adjusted

The drawings show the two positions for assembling and operating.



Example NGHP 080 A2, 1-stage

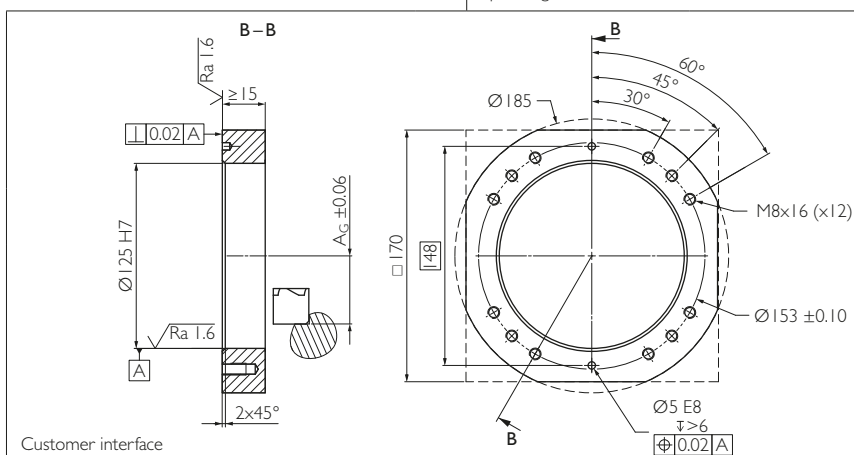

Customer interface

Your ideal drive train

Function Package with gearbox, rack and pinion from Güdel

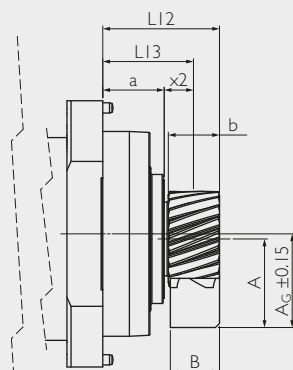
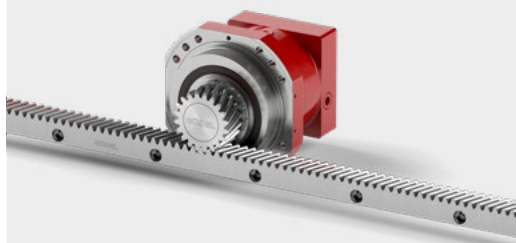

Detail output shaft

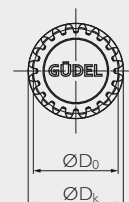

Material 16MnCr5
DIN 1.7131
Teeth pressure angle $\alpha = 20^\circ$,
helical teeth left,
 $19^\circ 31' 42''$,
hardened (58^{+1} HRC),
ground, crowned
Quality 6f24 DIN 3962 / 63 / 67

Pinion



	m_n	P_t	z	A	A_G	b	D_k	D_0	D_v	L12	L13	x2	a	M	
Pinion 1	[-]	2	6.66	25	48.526	51.526	25	57.05	53.052	53.052	57.0	44.5	15.5	29	0.4
Pinion 2	[-]	3	10.00	20	57.831	60.831	30	69.66	63.662	63.662	62.0	47.0	18.0	29	0.7

m_n : Normal module, P_t : Transverse pitch [mm], z : Number of teeth, A_G : Gearbox position, D_0 : Pitch circle diameter for calculation, D_v : Pitch circle diameter for design, M: Weight [kg]

Available ratios	i		I-stage						
			3	4	5	7	10		
Nominal torque S5 ^{a)}	T _{2N}	[Nm]	200	260	270	250	150		
Acceleration torque S5 ^{b)}	T _{2B}	[Nm]	320	350	350	330	265		
Nominal input speed S5 ^{c)}	n _{1N}	[rpm]	1 300	2 300	2 600	2 600	2 600		
Maximum input speed S5	n _{1max}	[rpm]	1 700	4 500	4 500	4 500	4 500		
Nominal torque S1 ^{a)}	T _{2N}	[Nm]	–	175	175	175	115		
Acceleration torque S1 ^{b)}	T _{2B}	[Nm]	–	250	250	250	190		
Nominal input speed S1 ^{c)}	n _{1N}	[rpm]	–	1 500	1 600	1 800	1 800		
Maximum input speed S1	n _{1max}	[rpm]	–	2 000	2 000	2 800	2 800		
Emergency stop torque ^{d)}	T _{2not}	[Nm]	500	630	630	630	630		
Efficiency	η	[%]	97						
Lifetime	L _h	[h]	> 20 000						
Weight	M	[kg]	9						
Angular backlash	i _c	[arcmin]	Precision P 1 ≤ 1 / P 3 ≤ 3 / P 5 ≤ 5						
Tilting moment	M _{kmax}	[Nm]	614						
Torsionnal rigidity ^{e)}	C _{t2}	[Nm/arcmin]	78	82	88	78	64		
Tilting rigidity ^{e)}	C _{t2}	[Nm/arcmin]	458						
Noise ⁱ⁾	L _{pA}	[dB(A)]	< 62						
Max. permitted housing temperature ^{g)}	T	[°C]	90						
Protection class			IP 65						
Direction of rotation			Same way input / output						
Max. axial force on output shaft ^{f)}	F _{amax}	[N]	4 800						
Color			Red, RAL 3003						
Inertia in kg.cm ² ^{h)}	Ø	J ₁	[kgcm ²]	Ø 11	6.134	3.95	3.072	2.337	1.948
				Ø 14	6.114	3.93	3.052	2.317	1.928
				Ø 19	6.874	4.69	3.812	3.077	2.688
				Ø 24	7.194	5.01	4.132	3.397	3.008
				Ø 32	8.234	6.05	5.172	4.437	4.048
				Ø 35	14.364	12.18	11.302	10.567	10.178
				Ø 38	14.334	12.15	11.272	10.537	10.148

- a) Nominal output torque when operating at n_{1N}.
- b) 1000 cycles per hour max.
- c) Valid for an ambient temperature of 20°C and T_{2N}. At higher ambient temperatures, please reduce speed.
- d) Valid 1000 times the gear box life.

- e) Valid for an input Ø of 24 mm in 1-stage and 19 mm in 2-stage.
- f) Values for 300 rpm / 20000 h.
- g) For other temperatures, please contact us. Nominal output torque when operating at n_{1N}.
- h) Depending on the motor output shaft Ø.
- i) With i=10 and n_{1N}=3000 rpm no load.

Rack



			Pinion 1			Pinion 2			Pinion 3			Pinion 4		
			Q6	Q7	Q9	Q6	Q7	Q9	Q6	Q7	Q9	Q6	Q7	Q9
Max acceleration force	F _{2B}	[N]	7 075	1 760	4 752	7 505	3 217	5 016	10 570	2 813	7 620	15 076	3 661	11 052
Max acceleration torque	T _{2B}	[Nm]	120	30	81	167	72	112	224	60	162	336	82	246
Precision			P1 P5			P1 P5			P1 P5			P1 P5		
Feed force			High	Medium	Elevated	High	Medium	Elevated	High	Medium	Elevated	High	Medium	Elevated

For proper sizing follow flowchart calculate your ideal drive train on pages 136 et seq.

More on the technical datasheets your ideal drive train on pages 120 et seq.

Above values for rack and pinion take into consideration a number of load cycles: 1x10⁶ for the rack; 1x10⁷ for the pinion. Both in pulsating operation.

Input

A	for motor shaft	$L \leq 54$	$\varnothing d \leq 24$	result in LA
B	for motor shaft	$54 < L \leq 65$	$\varnothing d \leq 38$	result in LB
C	for motor shaft	$65 < L \leq 80$	$\varnothing d \leq 38$	result in LC

		1-stage	2-stage
LA	[mm]	132.1	183.1
LB	[mm]	143.1	194.1
LC	[mm]	163.1	214.1

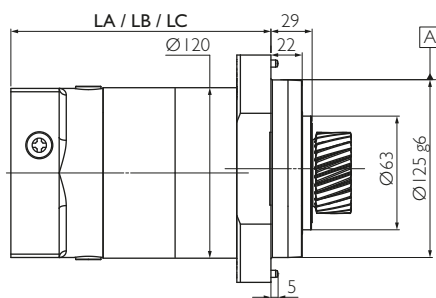
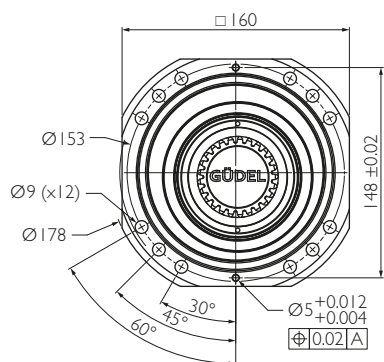

Output



gudel.com/gadjustment

Manual



gudel.com/manual/planetary-gearbox

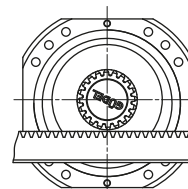

disengaged

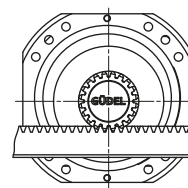

adjusted

The drawings show the two positions for assembling and operating.



Example NGHP 080 A2, 1-stage

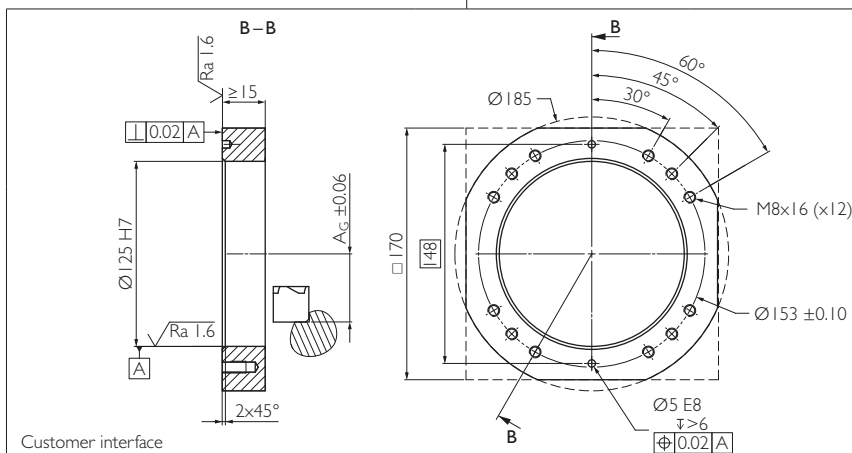

Customer interface

Your ideal drive train

Function Package with gearbox, rack and pinion from Güdel

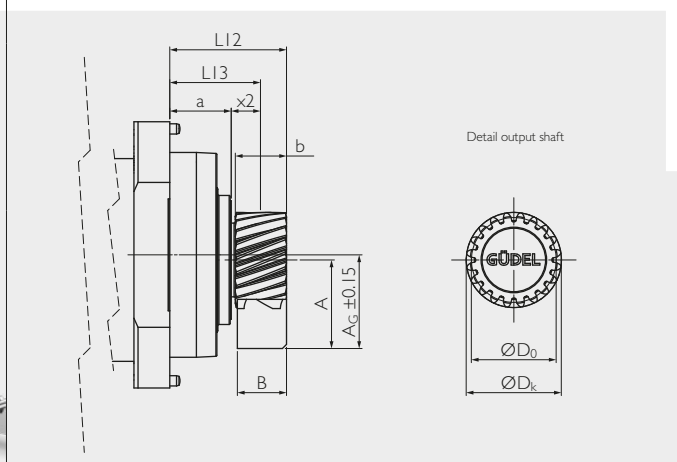
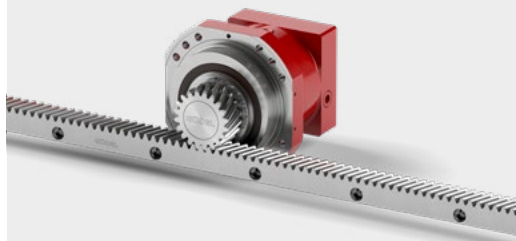

Detail output shaft

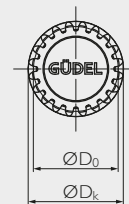

Material 16MnCr5
DIN 1.7131
Teeth pressure angle $\alpha = 20^\circ$,
helical teeth left,
 $19^\circ 31' 42''$,
hardened (58^{+1} HRC),
ground, crowned
Quality 6f24 DIN 3962 / 63 / 67

Pinion



	m_n	P_t	z	A	A_G	b	D_k	D_0	D_v	L12	L13	x2	a	M	
Pinion 1	[-]	2	6.66	25	48.526	51.526	25	57.05	53.052	53.052	57.0	44.5	15.5	29	0.4
Pinion 2	[-]	3	10.00	20	57.831	60.831	30	69.66	63.662	63.662	62.0	47.0	18.0	29	0.7

m_n : Normal module, P_t : Transverse pitch [mm], z : Number of teeth, A_G : Gearbox position, D_0 : Pitch circle diameter for calculation, D_v : Pitch circle diameter for design, M: Weight [kg]

Available ratios *	i		2-stage											
			12	16	20	25	30	35	40	50	70	100		
Nominal torque S5 ^{a)}	T _{2N}	[Nm]	200	260	270	270	200	270	260	270	250	150		
Acceleration torque S5 ^{b)}	T _{2B}	[Nm]	320	350	350	350	320	350	350	320	330	265		
Nominal input speed S5 ^{c)}	n _{1N}	[rpm]	2 400	2 900	2 900	2 900	2 900	2 900	2 900	3 200	3 600	4 300		
Maximum input speed S5	n _{1max}	[rpm]	5 000	6 000	6 000	6 000	6 000	6 000	6 000	6 000	6 000	6 000		
Nominal torque S1 ^{a)}	T _{2N}	[Nm]	175	175	175	175	175	175	175	175	175	115		
Acceleration torque S1 ^{b)}	T _{2B}	[Nm]	250	250	250	250	250	250	250	250	250	190		
Nominal input speed S1 ^{c)}	n _{1N}	[rpm]	2 000	2 000	2 000	2 000	2 000	2 000	2 000	2 000	2 000	2 500		
Maximum input speed S1	n _{1max}	[rpm]	3 000	3 100	3 100	3 100	3 100	3 100	3 100	3 100	3 500	4 000		
Emergency stop torque ^{d)}	T _{2not}	[Nm]	630	630	630	630	630	630	630	630	630	630		
Efficiency	η	[%]	94											
Lifetime	L _h	[h]	> 20 000											
Weight	M	[kg]	12.5											
Angular backlash	i _c	[arcmin]	Precision P 1 ≤ 1 / P 3 ≤ 3 / P 5 ≤ 5											
Tilting moment	M _{kmax}	[Nm]	614											
Torsionnal rigidity ^{e)}	C _{t2}	[Nm/arcmin]	78	81	87	87	87	87	81	87	77	64		
Tilting rigidity ^{e)}	C _{t2}	[Nm/arcmin]	458											
Noise ⁱ⁾	L _{pA}	[dB(A)]	< 62											
Max. permitted housing temperature ^{g)}	T	[°C]	90											
Protection class			IP 65											
Direction of rotation			Same way input / output											
Max. axial force on output shaft ^{f)}	F _{amax}	[N]	4 800											
Color			Red, RAL 3003											
Inertia in kg.cm ² ^{h)}	Ø	J ₁	[kgcm ²]	Ø11	3.033	2.896	2.841	2.363	1.802	1.976	1.78	1.771	1.764	1.76
				Ø14	3.013	2.876	2.821	2.343	1.782	1.956	1.76	1.751	1.744	1.74
				Ø19	3.773	3.636	3.581	3.103	2.542	2.716	2.52	2.511	2.504	2.5
				Ø24	4.093	3.956	3.901	3.423	2.862	3.036	2.84	2.831	2.824	2.82
				Ø32	5.133	4.996	4.941	4.463	3.902	4.076	3.88	3.871	3.864	3.86
				Ø35	11.263	11.126	11.071	10.593	10.032	10.206	10.01	10.001	9.994	9.99
				Ø38	11.233	11.096	11.041	10.563	10.002	10.176	9.98	9.971	9.964	9.96

- * Other ratios available. 9, 15, 21, 27, 28, 49 on request.
- a) Nominal output torque when operating at n_{1N}.
- b) 1000 cycles per hour max.
- c) Valid for an ambient temperature of 20°C and T_{2N}. At higher ambient temperatures, please reduce speed.
- d) Valid 1000 times the gearbox life.

- e) Valid for an input Ø of 24 mm in 1-stage and 19 mm in 2-stage.
- f) Values for 300 rpm / 20000 h.
- g) For other temperatures, please contact us. Nominal output torque when operating at n_{1N}.
- h) Depending on the motor output shaft Ø.
- i) With i=10 and n_{1N}=3000 rpm no load.

Rack



			Pinion 1			Pinion 2			Pinion 3			Pinion 4		
			Q6	Q7	Q9	Q6	Q7	Q9	Q6	Q7	Q9	Q6	Q7	Q9
Max acceleration force	F _{2B}	[N]	7 075	1 760	4 752	7 505	3 217	5 016	10 570	2 813	7 620	15 076	3 661	11 052
Max acceleration torque	T _{2B}	[Nm]	120	30	81	167	72	112	224	60	162	336	82	246
Precision			PI		P5	PI		P5	PI		P5	PI		P5
Feed force			High	Medium	Elevated	High	Medium	Elevated	High	Medium	Elevated	High	Medium	Elevated

For proper sizing follow flowchart calculate your ideal drive train on pages 136 et seq.

More on the technical datasheets your ideal drive train on pages 120 et seq.

Above values for rack and pinion take into consideration a number of load cycles: 1x10⁶ for the rack; 1x10⁷ for the pinion. Both in pulsating operation.

Input

Output



A for motor shaft L ≤ 62 Ød ≤ 38 result in LA
B for motor shaft 62 < L ≤ 115 Ød ≤ 48 result in LB



gudel.com/gadjustment



gudel.com/manual/planetary-gearbox

		I-stage	2-stage
LA	[mm]	156.5	189.5
LB	[mm]	208.5	200.5
LC	[mm]		220.5

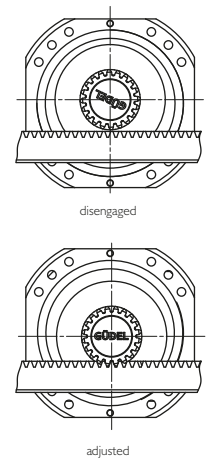
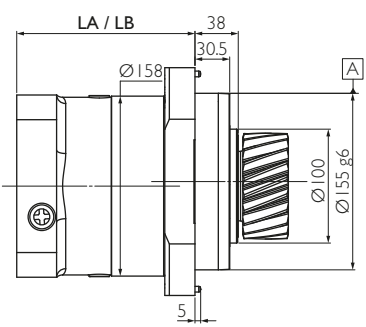
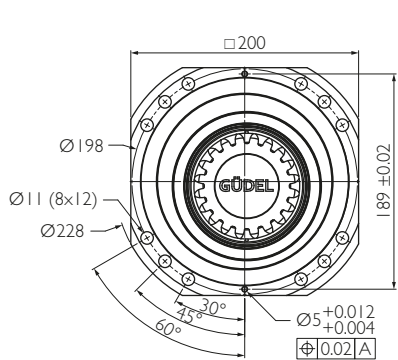

The drawings show the two positions for assembling and operating.



Example NGHP 080 A2, 1-stage

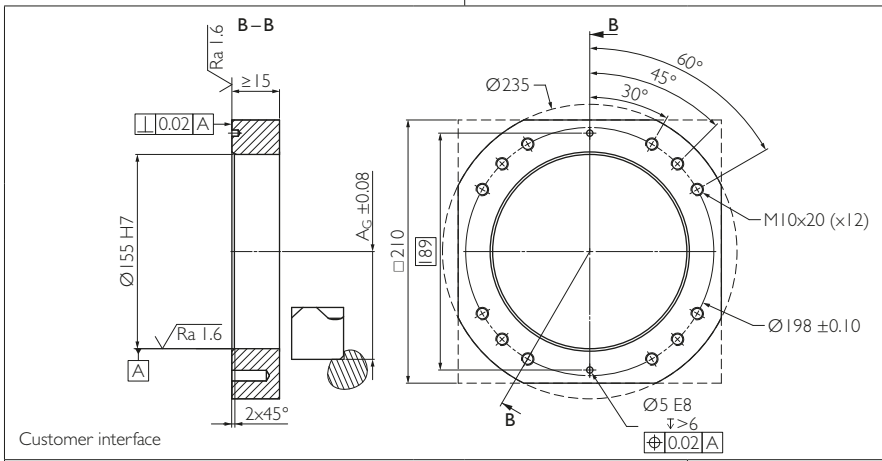

Customer interface

Your ideal drive train

Function Package with gearbox, rack and pinion from Güdel

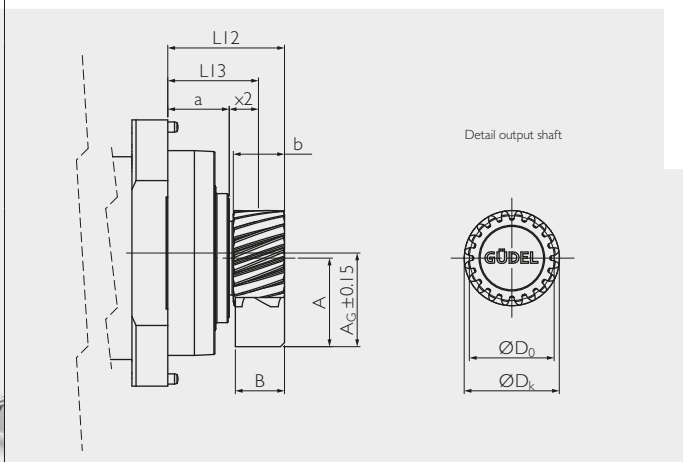
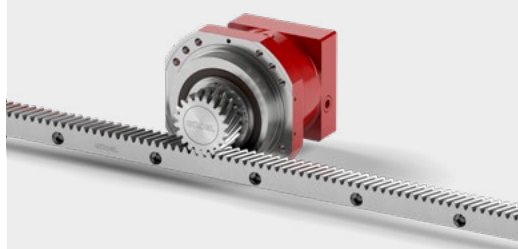

Detail output shaft

Material 16MnCr5
 DIN 1.7131
 Teeth pressure angle α = 20°,
 helical teeth left,
 19°31'42",
 hardened (58⁺¹ HRC),
 ground, crowned
 Quality 6f24 DIN 3962 / 63 / 67

Pinion



	m _n	P _t	z	A	A _G	b	D _k	D ₀	D _v	L12	L13	x2	a	M	
Pinion 1	[-]	3	10.00	22	61.014	65.014	30	76.03	70.028	70.028	72.0	57.0	19.0	38	0.8
Pinion 2	[-]	4	13.33	20	77.441	81.441	40	92.88	84.883	84.883	82.0	62.0	24.0	38	1.6

m_n: Normal module, P_t: Transverse pitch [mm], z: Number of teeth, A_G: Gearbox position, D₀: Pitch circle diameter for calculation, D_v: Pitch circle diameter for design, M: Weight [kg]

Available ratios	i		I-stage						
			3	4	5	7	10		
Nominal torque S5 ^{a)}	T _{2N}	[Nm]	400	490	500	470	310		
Acceleration torque S5 ^{b)}	T _{2B}	[Nm]	520	650	650	650	500		
Nominal input speed S5 ^{c)}	n _{1N}	[rpm]	1 500	1 900	2 100	2 500	2 600		
Maximum input speed S5	n _{1max}	[rpm]	2 500	4 000	4 000	4 000	4 000		
Nominal torque S1 ^{a)}	T _{2N}	[Nm]	–	260	260	260	130		
Acceleration torque S1 ^{b)}	T _{2B}	[Nm]	–	370	370	370	220		
Nominal input speed S1 ^{c)}	n _{1N}	[rpm]	–	900	1 000	1 200	1 200		
Maximum input speed S1	n _{1max}	[rpm]	–	1 600	1 600	2 600	2 600		
Emergency stop torque ^{d)}	T _{2not}	[Nm]	1 300	1 300	1 300	1 300	1 260		
Efficiency	η	[%]	97						
Lifetime	L _h	[h]	> 20 000						
Weight	M	[kg]	17						
Angular backlash	i _c	[arcmin]	Precision P 1 ≤ 1 / P 3 ≤ 3 / P 5 ≤ 5						
Tilting moment	M _{kmax}	[Nm]	1 400						
Torsionnal rigidity ^{e)}	C _{t2}	[Nm/arcmin]	180	195	193	164	128		
Tilting rigidity ^{e)}	C _{t2}	[Nm/arcmin]	934						
Noise ⁱ⁾	L _{pA}	[dB(A)]	< 62						
Max. permitted housing temperature ^{g)}	T	[°C]	90						
Protection class			IP 65						
Direction of rotation			Same way input / output						
Max. axial force on output shaft ^{f)}	F _{amax}	[N]	7 600						
Color			Red, RAL 3003						
Inertia in kg.cm ² ^{h)}	Ø	J ₁	[kgcm ²]	Ø19	16.069	9.704	7.173	5.003	3.881
				Ø24	16.389	10.024	7.493	5.323	4.201
				Ø32	22.249	15.884	13.353	11.183	10.061
				Ø35	22.839	16.474	13.943	11.773	10.651
				Ø38	23.309	16.944	14.413	12.243	11.121
				Ø42	23.639	17.274	14.743	12.573	11.451
				Ø48	27.619	21.254	18.723	16.553	15.431

- a) Nominal output torque when operating at n_{1N}.
- b) 1 000 cycles per hour max.
- c) Valid for an ambient temperature of 20°C and T_{2N}.
At higher ambient temperatures, please reduce speed.
- d) Valid 1 000 times the gear box life.

- e) Valid for an input Ø of 38 mm in 1-stage and 24 mm in 2-stage.
- f) Values for 300 rpm / 20 000 h.
- g) For other temperatures, please contact us. Nominal output torque when operating at n_{1N}.
- h) Depending on the motor output shaft Ø.
- i) With i=10 and n_{1N}=3000 rpm no load.

Rack



			Pinion 1			Pinion 2		
			Q6	Q7	Q9	Q6	Q7	Q9
Max acceleration force	F _{2B}	[N]	11 216	5 197	8 053	15 790	6 350	12 686
Max acceleration torque	T _{2B}	[Nm]	312	145	224	452	182	363
Precision			PI		P5	PI		P5
Feed force			High	Medium	Elevated	High	Medium	Elevated

Above values for rack and pinion take into consideration a number of load cycles:
1x10⁶ for the rack; 1x10⁷ for the pinion. Both in pulsating operation.

For proper sizing follow flowchart
calculate your ideal drive train
on pages 136 et seq.

More on the technical datasheets
your ideal drive train on pages
120 et seq.

Input

- A** for motor shaft $L \leq 54$
- B** for motor shaft $54 < L \leq 65$
- C** for motor shaft $65 < L \leq 80$

		1-stage	2-stage
LA	[mm]	156.5	189.5
LB	[mm]	208.5	200.5
LC	[mm]		220.5

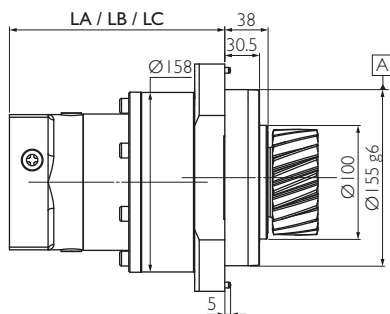
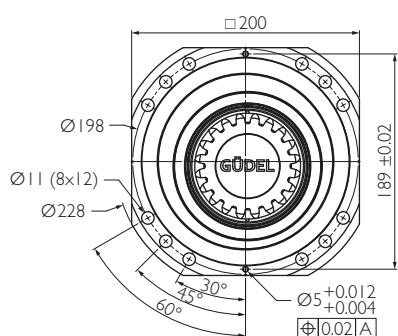

Output



gudel.com/gadjustment

Manual



gudel.com/manual/planetary-gearbox

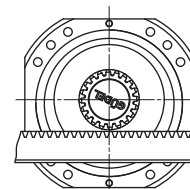

disengaged

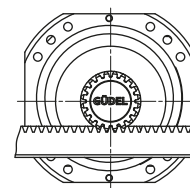

adjusted

The drawings show the two positions for assembling and operating.



Example NGHP 080 A2, 1-stage

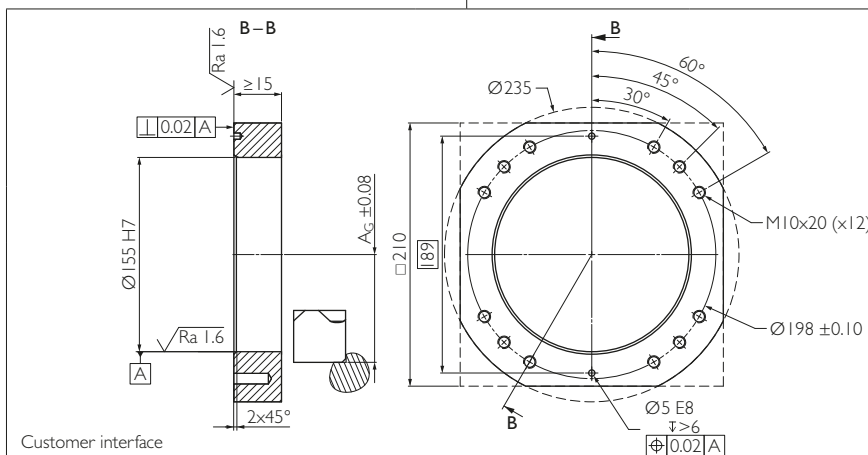

Customer interface

Your ideal drive train

Function Package with gearbox, rack and pinion from Güdel

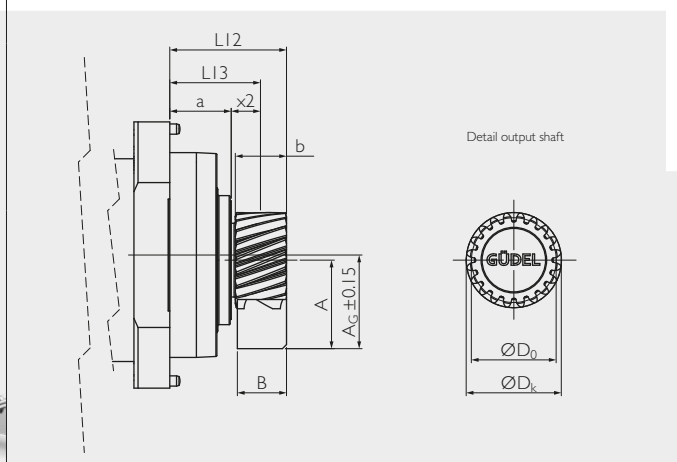
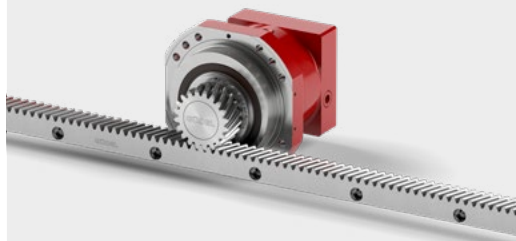

Detail output shaft

Material 16MnCr5
 DIN 1.7131
 Teeth pressure angle $\alpha = 20^\circ$,
 helical teeth left,
 $19^\circ 31' 42''$,
 hardened (58^{+1} HRC),
 ground, crowned
 Quality 6f24 DIN 3962 / 63 / 67

Pinion



	m_n	P_t	z	A	A_G	b	D_k	D_0	D_v	L12	L13	x2	a	M	
Pinion 1	[-]	3	10.00	22	61.014	65.014	30	76.03	70.028	70.028	72.0	57.0	19.0	38	0.8
Pinion 2	[-]	4	13.33	20	77.441	81.441	40	92.88	84.883	84.883	82.0	62.0	24.0	38	1.6

m_n : Normal module, P_t : Transverse pitch [mm], z : Number of teeth, A_G : Gearbox position, D_0 : Pitch circle diameter for calculation, D_v : Pitch circle diameter for design, M: Weight [kg]

Available ratios *	i		2-stage										
			12	16	20	25	30	35	40	50	70	100	
Nominal torque S5 ^{a)}	T _{2N}	[Nm]	400	490	500	500	400	500	490	500	470	310	
Acceleration torque S5 ^{b)}	T _{2B}	[Nm]	520	650	650	650	600	650	650	650	650	500	
Nominal input speed S5 ^{c)}	n _{1N}	[rpm]	2 900	2 900	2 900	3 000	3 000	3 000	3 000	3 300	3 300	4 000	
Maximum input speed S5	n _{1max}	[rpm]	4 200	4 200	4 200	5 000	5 000	5 000	5 000	5 000	5 000	5 000	
Nominal torque S1 ^{a)}	T _{2N}	[Nm]	260	260	260	260	260	260	260	260	260	150	
Acceleration torque S1 ^{b)}	T _{2B}	[Nm]	370	370	370	370	370	370	370	370	370	220	
Nominal input speed S1 ^{c)}	n _{1N}	[rpm]	1 400	1 400	1 800	1 800	2 000	2 000	2 000	2 000	2 200	2 200	
Maximum input speed S1	n _{1max}	[rpm]	2 700	2 900	2 800	2 800	2 800	2 800	2 800	3 000	3 000	3 200	
Emergency stop torque ^{d)}	T _{2not}	[Nm]	1 300	1 300	1 300	1 300	1 300	1 300	1 300	1 300	1 300	1 260	
Efficiency	η	[%]	94										
Lifetime	L _h	[h]	> 20 000										
Weight	M	[kg]	20										
Angular backlash	i _c	[arcmin]	Precision P 1 ≤ 1 / P 3 ≤ 3 / P 5 ≤ 5										
Tilting moment	M _{kmax}	[Nm]	1 400										
Torsionnal rigidity ^{e)}	C _{t2}	[Nm/arcmin]	170	185	185	183	160	183	177	178	147	117	
Tilting rigidity ^{e)}	C _{t2}	[Nm/arcmin]	934										
Noise ⁱ⁾	L _{pA}	[dB(A)]	< 62										
Max. permitted housing temperature ^{g)}	T	[°C]	90										
Protection class			IP 65										
Direction of rotation			Same way input / output										
Max. axial force on output shaft ^{f)}	F _{amax}	[N]	7 600										
Color			Red, RAL 3003										
Inertia in kg.cm ² ^{h)}	Ø14	J ₁	[kgcm ²]	3.556	3.158	3	2.457	1.869	2.014	1.805	1.78	1.758	1.747
	Ø19			4.316	3.918	3.76	3.217	2.629	2.774	2.565	2.54	2.518	2.507
	Ø24			4.636	4.238	4.08	3.537	2.949	3.094	2.885	2.86	2.838	2.827
	Ø32			5.676	5.278	5.12	4.577	3.989	4.134	3.925	3.9	3.878	3.867
	Ø35			11.806	11.408	11.25	10.707	10.119	10.264	10.055	10.03	10.008	9.997
	Ø38			11.776	11.378	11.22	10.677	10.089	10.234	10.025	10	9.978	9.967

- * Other ratios available. 9, 15, 21, 27, 28, 49 on request.
- a) Nominal output torque when operating at n_{1N}.
- b) 1 000 cycles per hour max.
- c) Valid for an ambient temperature of 20°C and T_{2N}.
At higher ambient temperatures, please reduce speed.
- d) Valid 1 000 times the gear box life.

- e) Valid for an input Ø of 38 mm in 1-stage and 24 mm in 2-stage.
- f) Values for 300 rpm / 20000 h.
- g) For other temperatures, please contact us. Nominal output torque when operating at n_{1N}.
- h) Depending on the motor output shaft Ø.
- i) With i=10 and n_{1N}=3000 rpm no load.

Rack



			Pinion 1			Pinion 2		
			Q6	Q7	Q9	Q6	Q7	Q9
Max acceleration force	F _{2B}	[N]	11 216	5 197	8 053	15 790	6 350	12 686
Max acceleration torque	T _{2B}	[Nm]	312	145	224	452	182	363
Precision			PI		P5	PI		P5
Feed force			High	Medium	Elevated	High	Medium	Elevated

For proper sizing follow flowchart
calculate your ideal drive train
on pages 136 et seq.

More on the technical datasheets
your ideal drive train on pages
120 et seq.

Above values for rack and pinion take into consideration a number of load cycles:
1x10⁶ for the rack; 1x10⁷ for the pinion. Both in pulsating operation.

Input

A	for motor shaft	$L \leq 60$	$19 \leq \varnothing d \leq 32$	result in LA
B	for motor shaft	$60 < L \leq 85$	$32 < \varnothing d \leq 48$	result in LB
C	for motor shaft	$85 < L \leq 111$	$32 < \varnothing d \leq 48$	result in LC

		I-stage	2-stage	3-stage
LA	[mm]	168	220	273
LB	[mm]	193	246	298
LC	[mm]	219	272	

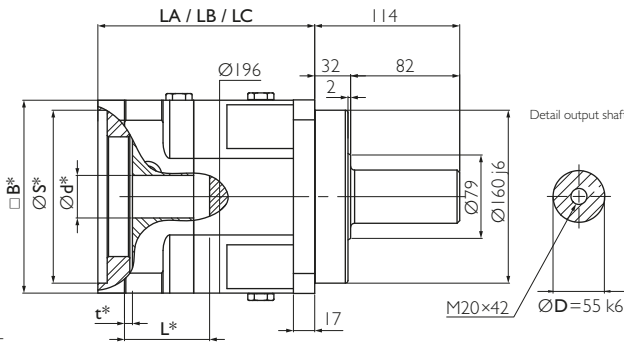
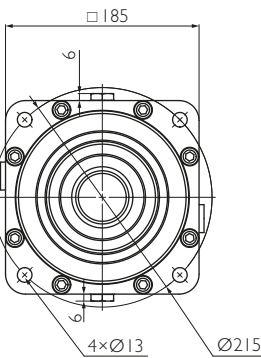

* depending on the motor. See pages 130 et seq.



Example NR 180 C0, 1-stage

Output

Standard

Optional

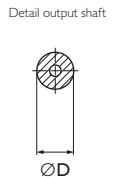
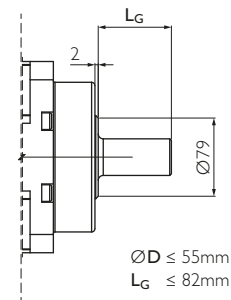
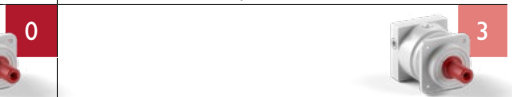

Option 3 on request. Adjustments can reduce capacity.

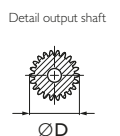
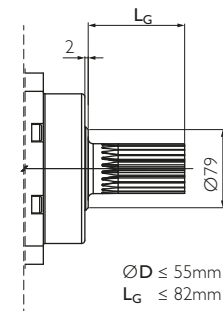
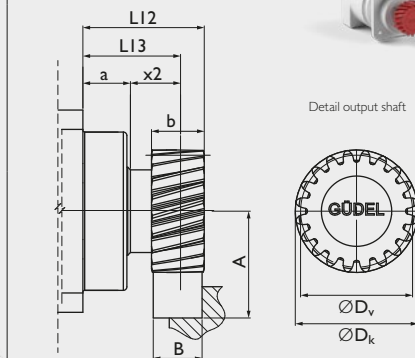
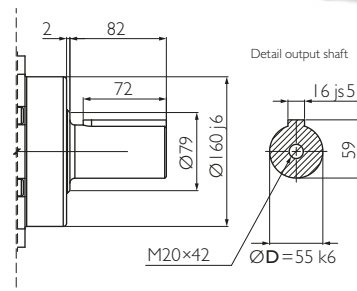
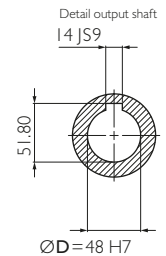
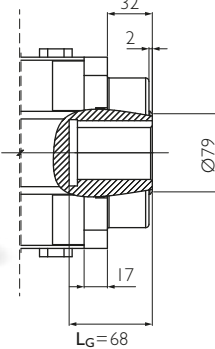

Option 5 on request. Adjustments can reduce capacity.

Material 16MnCr5 DIN 1.7131
 Teeth pressure angle $\alpha = 20^\circ$, helical teeth left, $19^\circ 31' 42''$ hardened (58⁺⁴HRC), ground, crowned
 Quality 6f24 DIN 3962 / 63 / 67

Your ideal drive train

Function Package with gearbox, rack and pinion from Güdel

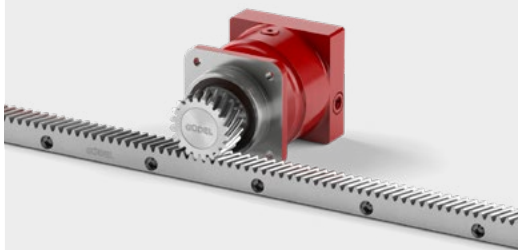

Pinion

	m_n	P_t	z	A	b	D_k	D_0	D_v	L12	L13	x2	a	M	
Pinion 1	[-]	4	13.33	20	77.441	40	92.88	84.883	84.883	83.5	63.5	31.5	32	1.5
Pinion 2	[-]	5	16.66	20	87.052	50	116.10	106.103	106.103	89.5	64.5	32.5	32	3.0

m_n : Normal module, P_t : Transverse pitch [mm], z : Number of teeth, D_0 : Pitch circle diameter for calculation, D_v : Pitch circle diameter for design, M: Weight [kg]

Available ratios	i		I-stage					
			3	4	5	7	10	
Nominal torque S5 ^{a)}	T _{2N}	[Nm]	750	770	780	760	680	
Acceleration torque S5 ^{b)}	T _{2B}	[Nm]	1 150	1 150	1 150	1 150	880	
Nominal input speed S5 ^{c)}	n _{1N}	[rpm]	1 500	1 500	1 500	2 300	2 300	
Maximum input speed S5	n _{1max}	[rpm]	3 000	3 500	3 500	3 500	3 500	
Nominal torque S1 ^{a)}	T _{2N}	[Nm]	380	380	380	380	340	
Acceleration torque S1 ^{b)}	T _{2B}	[Nm]	560	560	560	560	570	
Nominal input speed S1 ^{c)}	n _{1N}	[rpm]	1 100	1 300	1 300	2 100	2 100	
Maximum input speed S1	n _{1max}	[rpm]	1 500	1 500	1 500	2 300	2 300	
Emergency stop torque ^{d)}	T _{2not}	[Nm]	2 550	2 780	2 780	2 780	2 250	
Efficiency	η	[%]	97					
Lifetime	L _h	[h]	> 20 000					
Weight	M	[kg]	32					
Angular backlash	j _t	[arcmin]	Precision P I ≤ 1 / P 3 ≤ 3 / P 5 ≤ 5 / P I2 ≤ 12					
Torsionnal rigidity ^{e)}	C _{t2}	[Nm/arcmin]	156.3	182.7	193.5	210.1	183.3	
Noise ⁱ⁾	L _{pA}	[dB(A)]	≤ 71					
Max. permitted housing temperature ^{g)}	T	[°C]	90					
Protection class			IP 65					
Direction of rotation			Same way input / output					
Max. radial force on output shaft ^{f)}	F _{Rmax}	[N]	Center of output shaft: 15 500 / End of output shaft: 11 500					
Max. axial force on output shaft ^{f)}	F _{Amax}	[N]	15 000					
Color			Red, RAL 3003					
Inertia in kg.cm ² ^{h)}	Ø19	J _I	[kgcm ²]	38.19	23.35	17.21	12.12	9.18
	Ø24			39.24	24.40	18.26	13.17	10.23
	Ø32			41.45	26.61	20.47	15.38	12.44
	Ø35			44.37	29.53	23.39	18.30	15.36
	Ø38			49.97	35.13	28.99	23.90	20.96
	Ø42			49.47	34.63	28.49	23.40	20.46
	Ø48			49.87	35.03	28.89	23.80	20.86

- a) Nominal output torque when operating at n_{1N}.
- b) 1000 cycles per hour max.
- c) Valid for an ambient temperature of 20°C and T_{2N}.
At higher ambient temperatures, please reduce speed.
- d) Valid 1000 times the gearbox life.

- e) Valid for an input Ø of 48 mm in 1-stage and 38 mm in 2- and 3-stage.
- f) Values for 300 rpm.
- g) For other temperatures, please contact us. Nominal output torque when operating at n_{1N}.
- h) Depending on the motor output shaft Ø.
- i) With i=10 and n_{1N}=3000 rpm no load.

Rack



			Pinion 1			Pinion 2		
			Q6	Q7	Q9	Q6	Q7	Q9
Max acceleration force	F _{2B}	[N]	28 585	14 084	24 045	44 505	23 785	40 048
Max acceleration torque	T _{2B}	[Nm]	1 213	598	1 021	2 361	1 262	2 125
Precision			PI		PI2	PI		PI2
Feed force			High	Medium	Elevated	High	Medium	Elevated

Above values for rack and pinion take into consideration a number of load cycles: 1x10⁶ for the rack; 1x10⁷ for the pinion. Both in pulsating operation.

For proper sizing follow flowchart calculate your ideal drive train on pages 136 et seq.

More on the technical datasheets your ideal drive train on pages 120 et seq.

Input

A	for motor shaft	$L \leq 60$	$19 \leq \varnothing d \leq 32$	result in LA
B	for motor shaft	$60 < L \leq 85$	$32 < \varnothing d \leq 48$	result in LB
C	for motor shaft	$85 < L \leq 111$	$32 < \varnothing d \leq 48$	result in LC

		1-stage	2-stage	3-stage
LA	[mm]	168	220	273
LB	[mm]	193	246	298
LC	[mm]	219	272	

Output

Standard



Optional

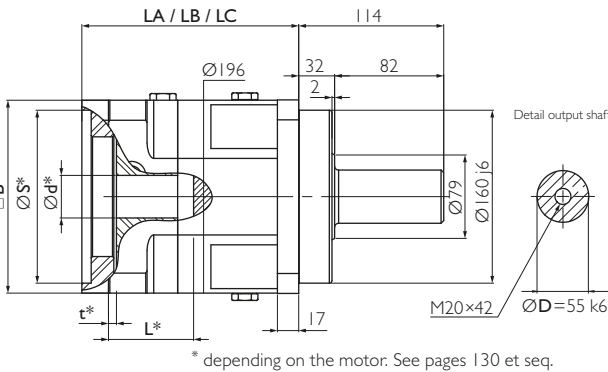
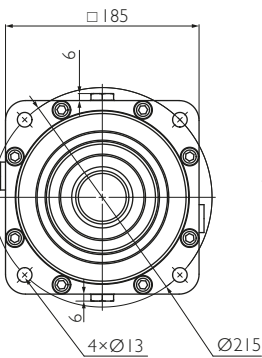

* depending on the motor. See pages 130 et seq.

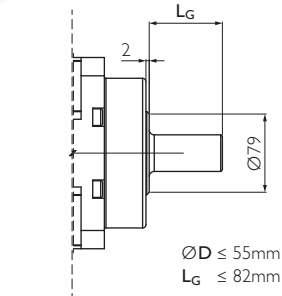

Detail output shaft

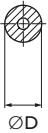

Option 3 on request. Adjustments can reduce capacity.

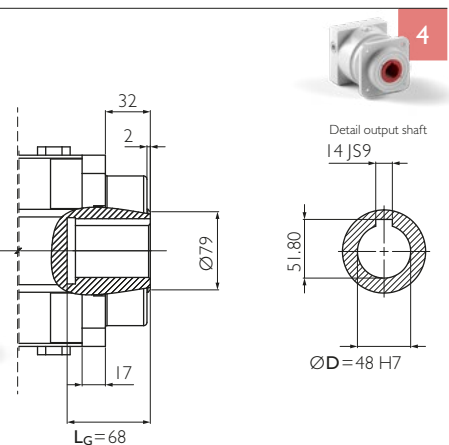

Detail output shaft

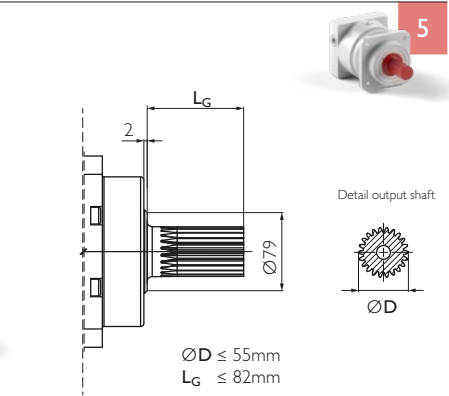
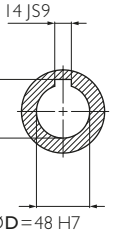

Detail output shaft



Option 5 on request. Adjustments can reduce capacity.



Example NR 180 A5, 1-stage

Your ideal drive train

Function Package with gearbox, rack and pinion from Güdel

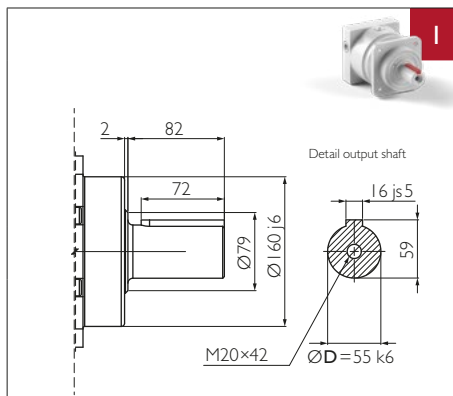
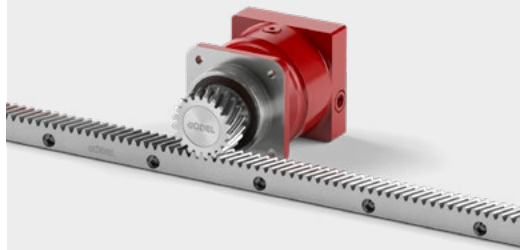

Detail output shaft

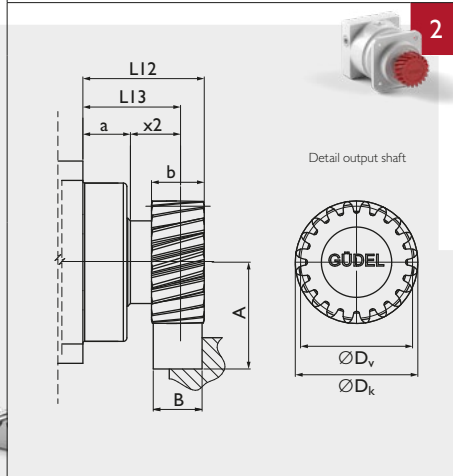
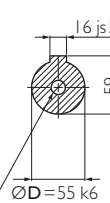

Detail output shaft

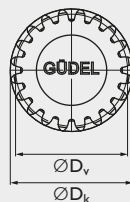

Material 16MnCr5 DIN 1.7131
 Teeth pressure angle $\alpha = 20^\circ$, helical teeth left, $19^\circ 31' 42''$ hardened (58⁺⁴ HRC), ground, crowned
 Quality 6f24 DIN 3962 / 63 / 67

Pinion



	m_n	P_t	z	A	b	D_k	D_0	D_v	L12	L13	x2	a	M	
Pinion 1	[-]	4	13.33	20	77.441	40	92.88	84.883	84.883	83.5	63.5	31.5	32	1.5
Pinion 2	[-]	5	16.66	20	87.052	50	116.10	106.103	106.103	89.5	64.5	32.5	32	3.0

m_n : Normal module, P_t : Transverse pitch [mm], z : Number of teeth, D_0 : Pitch circle diameter for calculation, D_v : Pitch circle diameter for design, M: Weight [kg]

Available ratios *	i		2-stage										
			12	16	20	25	30	35	40	50	70	100	
Nominal torque S5 ^{a)}	T _{2N}	[Nm]	750	770	780	780	750	780	770	780	760	680	
Acceleration torque S5 ^{b)}	T _{2B}	[Nm]	1 150	1 150	1 150	1 150	1 150	1 150	1 150	1 150	1 150	880	
Nominal input speed S5 ^{c)}	n _{1N}	[rpm]	2 500	2 700	2 700	2 700	2 700	2 700	2 700	2 900	2 900	3 400	
Maximum input speed S5	n _{1max}	[rpm]	3 800	3 800	3 800	3 800	3 800	3 800	3 800	3 800	3 800	3 800	
Nominal torque S1 ^{a)}	T _{2N}	[Nm]	380	380	380	380	380	380	380	380	380	340	
Acceleration torque S1 ^{b)}	T _{2B}	[Nm]	560	560	560	560	560	560	560	560	570	570	
Nominal input speed S1 ^{c)}	n _{1N}	[rpm]	1 700	2 400	2 400	2 400	2 400	2 400	2 400	2 600	2 600	3 000	
Maximum input speed S1	n _{1max}	[rpm]	2 500	2 700	2 700	2 700	2 700	2 700	2 700	2 900	2 900	3 400	
Emergency stop torque ^{d)}	T _{2not}	[Nm]	2 780	2 780	2 780	2 780	2 550	2 780	2 780	2 780	2 780	2 250	
Efficiency	η	[%]	94										
Lifetime	L _h	[h]	> 20 000										
Weight	M	[kg]	39										
Angular backlash	j _t	[arcmin]	Precision P 1 ≤ 1 / P 3 ≤ 3 / P 5 ≤ 5 / P 12 ≤ 12										
Torsionnal rigidity ^{e)}	C _{t2}	[Nm/arcmin]	140.6	164.4	174.0	174.0	140.6	174.0	164.4	174.0	189.2	165.0	
Noise ⁱ⁾	L _{pA}	[dB(A)]	≤ 71										
Max. permitted housing temperature ^{g)}	T	[°C]	90										
Protection class			IP 65										
Direction of rotation			Same way input / output										
Max. radial force on output shaft ^{f)}	F _{Rmax}	[N]	Center of output shaft: 15 500 / End of output shaft: 11 500										
Max. axial force on output shaft ^{f)}	F _{Amax}	[N]	15 000										
Color			Red, RAL 3003										
Inertia in kg.cm ² ^{h)}	Ø19	J ₁	[kg.cm ²]	23.57	22.65	16.76	16.51	9.22	11.77	9.07	9.01	8.96	8.93
	Ø24			24.62	23.7	17.81	17.56	10.27	12.82	10.12	10.06	10.01	9.98
	Ø32			26.83	25.91	20.02	19.77	12.48	15.03	12.33	12.27	12.22	12.19
	Ø35			29.75	28.83	22.94	22.69	15.4	17.95	15.25	15.19	15.14	15.11
	Ø38			35.35	34.43	28.54	28.29	21	23.55	20.85	20.79	20.74	20.71
	Ø42			34.85	33.93	28.04	27.79	20.5	23.05	20.35	20.29	20.24	20.21
	Ø48			35.25	34.33	28.44	28.19	20.9	23.45	20.75	20.69	20.64	20.61

- * Other ratios available. 9, 15, 21, 27, 28, 49 on request.
- a) Nominal output torque when operating at n_{1N}.
- b) 1 000 cycles per hour max.
- c) Valid for an ambient temperature of 20°C and T_{2N}.
At higher ambient temperatures, please reduce speed.
- d) Valid 1 000 times the gear box life.

- e) Valid for an input Ø of 48 mm in 1-stage and 38 mm in 2- and 3-stage.
- f) Values for 300 rpm.
- g) For other temperatures, please contact us. Nominal output torque when operating at n_{1N}.
- h) Depending on the motor output shaft Ø.
- i) With i=10 and n_{1N}=3000 rpm no load.

Rack



			Pinion 1			Pinion 2		
			Q6	Q7	Q9	Q6	Q7	Q9
Max acceleration force	F _{2B}	[N]	28 585	14 084	24 045	44 505	23 785	40 048
Max acceleration torque	T _{2B}	[Nm]	1 213	598	1 021	2 361	1 262	2 125
Precision			PI			P12		
Feed force			High	Medium	Elevated	High	Medium	Elevated

Above values for rack and pinion take into consideration a number of load cycles: 1x10⁶ for the rack; 1x10⁷ for the pinion. Both in pulsating operation.

For proper sizing follow flowchart **calculate your ideal drive train** on pages 136 et seq.

More on the technical datasheets **your ideal drive train** on pages 120 et seq.

Input

A	for motor shaft	$L \leq 60$	$19 \leq \varnothing d \leq 32$	result in LA	0
B	for motor shaft	$60 < L \leq 85$	$32 < \varnothing d \leq 48$	result in LB	
C	for motor shaft	$85 < L \leq 111$	$32 < \varnothing d \leq 48$	result in LC	

		1-stage	2-stage	3-stage
LA	[mm]	168	220	273
LB	[mm]	193	246	298
LC	[mm]	219	272	

Output

Standard Optional

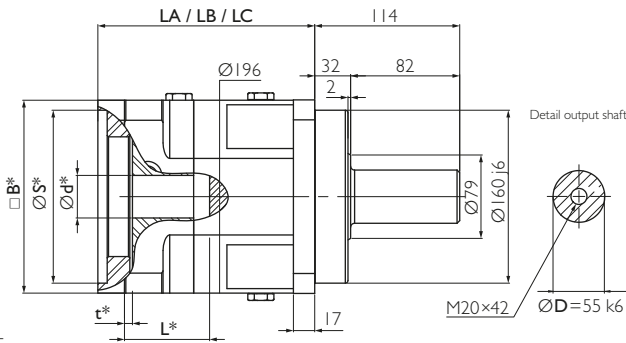
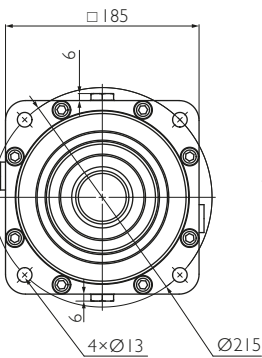

* depending on the motor. See pages 130 et seq.



Example NR 180 A0, 1-stage

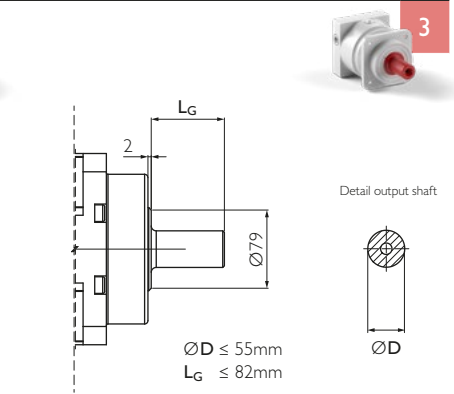

Detail output shaft



Option 3 on request. Adjustments can reduce capacity.

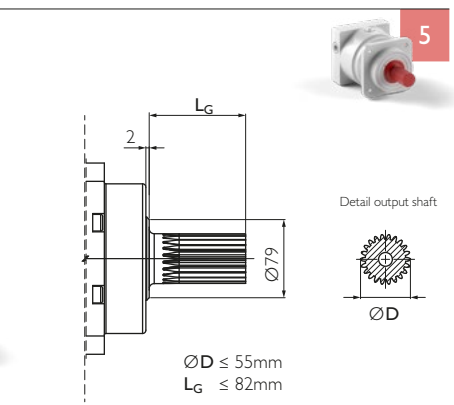
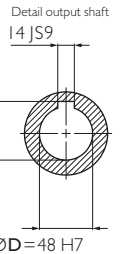
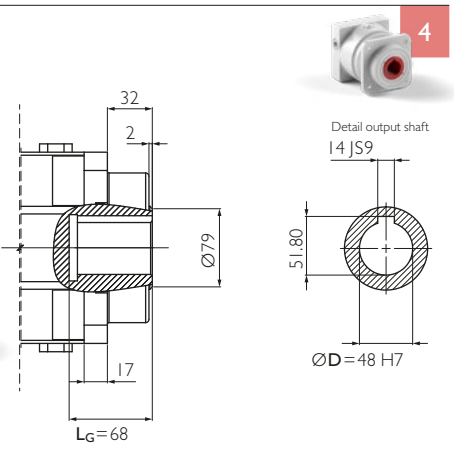

Detail output shaft



Option 5 on request. Adjustments can reduce capacity.

Your ideal drive train

Function Package with gearbox, rack and pinion from Güdel

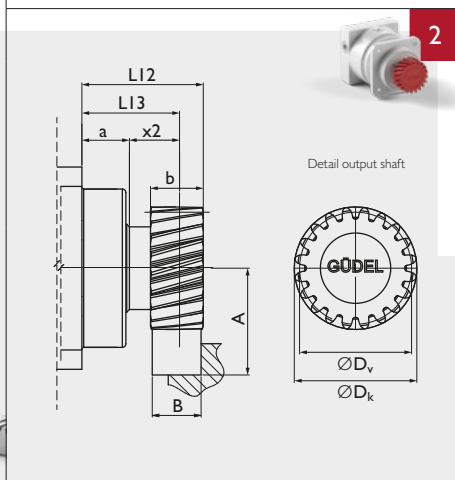
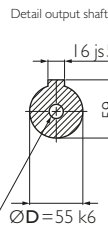
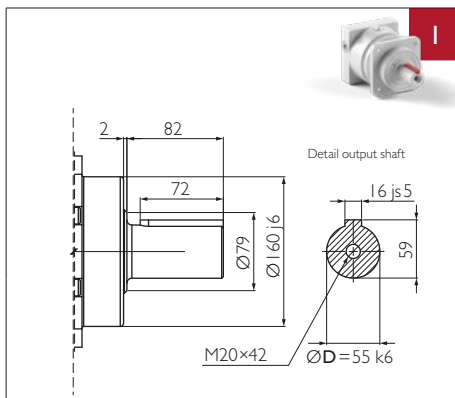
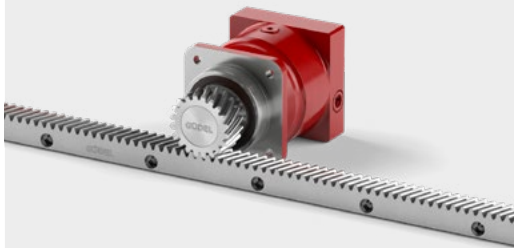

Material 16MnCr5 DIN 1.7131
 Teeth pressure angle $\alpha = 20^\circ$, helical teeth left, $19^\circ 31' 42''$ hardened (58⁺⁴HRC), ground, crowned
 Quality 6f24 DIN 3962 / 63 / 67

Pinion



	m_n	P_t	z	A	b	D_k	D_0	D_v	L12	L13	x2	a	M	
Pinion 1	[-]	4	13.33	20	77.441	40	92.88	84.883	84.883	83.5	63.5	31.5	32	1.5
Pinion 2	[-]	5	16.66	20	87.052	50	116.10	106.103	106.103	89.5	64.5	32.5	32	3.0

m_n : Normal module, P_t : Transverse pitch [mm], z : Number of teeth, D_0 : Pitch circle diameter for calculation, D_v : Pitch circle diameter for design, M: Weight [kg]

Available ratios *	i		3-stage									
			105	125	175	200	250	300	400	500	700	1 000
Nominal torque S5 ^{a)}	T _{2N}	[Nm]	780	780	780	780	780	750	770	780	760	680
Acceleration torque S5 ^{b)}	T _{2B}	[Nm]	1 150	1 150	1 150	1 150	1 150	1 150	1 150	1 150	1 150	880
Nominal input speed S5 ^{c)}	n _{1N}	[rpm]	3 400	3 400	3 400	3 400	3 400	3 400	3 400	3 400	3 400	3 400
Maximum input speed S5	n _{1max}	[rpm]	4 000	4 000	4 000	4 000	4 000	4 000	4 000	4 000	4 000	4 000
Nominal torque S1 ^{a)}	T _{2N}	[Nm]	400	400	400	400	400	400	400	400	400	340
Acceleration torque S1 ^{b)}	T _{2B}	[Nm]	570	570	570	570	570	570	570	570	570	570
Nominal input speed S1 ^{c)}	n _{1N}	[rpm]	3 000	3 000	3 000	3 000	3 000	3 000	3 000	3 000	3 000	3 000
Maximum input speed S1	n _{1max}	[rpm]	3 400	3 400	3 400	3 400	3 400	3 400	3 400	3 400	3 400	3 400
Emergency stop torque ^{d)}	T _{2not}	[Nm]	2 780	2 780	2 780	2 780	2 780	2 550	2 780	2 780	2 780	2 250
Efficiency	η	[%]	91									
Lifetime	L _h	[h]	> 20 000									
Weight	M	[kg]	46									
Angular backlash	j _t	[arcmin]	Precision P I ≤ 1 / P 3 ≤ 3 / P 5 ≤ 5 / P I 2 ≤ 12									
Torsionnal rigidity ^{e)}	C _{t2}	[Nm/arcmin]	165.3	165.3	165.5	133.3	165.3	133.3	156.3	165.3	179.5	156.6
Noise ⁱ⁾	L _{pA}	[dB(A)]	≤ 71									
Max. permitted housing temperature ^{g)}	T	[°C]	90									
Protection class			IP 65									
Direction of rotation			Same way input / output									
Max. radial force on output shaft ^{f)}	F _{Rmax}	[N]	Center of output shaft: 15 500 / End of output shaft: 11 500									
Max. axial force on output shaft ^{f)}	F _{Amax}	[N]	15 000									
Color			Red, RAL 3003									
Inertia in kg.cm ² ^{h)}	Ø19	J ₁	[kg.cm ²]	11.77	16.48	11.77	9.00	9.00	8.93	8.93	8.93	8.93
	Ø24			12.82	17.53	12.82	10.05	10.05	9.98	9.98	9.98	9.98
	Ø32			15.03	19.74	15.03	12.26	12.26	12.19	12.19	12.19	12.19
	Ø35			17.95	22.66	17.95	15.18	15.18	15.11	15.11	15.11	15.11
	Ø38			23.55	28.26	23.55	20.78	20.78	20.71	20.71	20.71	20.71
	Ø42			23.05	27.76	23.05	20.28	20.28	20.21	20.21	20.21	20.21
	Ø48			23.45	28.16	23.45	20.68	20.68	20.61	20.61	20.61	20.61

- * Other ratios available. 112, 120, 140, 147, 150, 160, 196, 210, 245, 280, 343, 350, 490 on request.
- a) Nominal output torque when operating at n_{1N}.
- b) 1000 cycles per hour max.
- c) Valid for an ambient temperature of 20°C and T_{2N}. At higher ambient temperatures, please reduce speed.

- d) Valid 1000 times the gearbox life.
- e) Valid for an input Ø of 48 mm in 1-stage and 38 mm in 2- and 3-stage.
- f) Values for 300 rpm.
- g) For other temperatures, please contact us. Nominal output torque when operating at n_{1N}.
- h) Depending on the motor output shaft Ø.
- i) With i=10 and n_{1N}=3000 rpm no load.

Rack



			Pinion 1			Pinion 2		
			Q6	Q7	Q9	Q6	Q7	Q9
Max acceleration force	F _{2B}	[N]	28 585	14 084	24 045	44 505	23 785	40 048
Max acceleration torque	T _{2B}	[Nm]	1 213	598	1 021	2 361	1 262	2 125
Precision			PI			P12		
Feed force			High	Medium	Elevated	High	Medium	Elevated

Above values for rack and pinion take into consideration a number of load cycles: 1x10⁶ for the rack; 1x10⁷ for the pinion. Both in pulsating operation.

For proper sizing follow flowchart calculate your ideal drive train on pages 136 et seq.

More on the technical datasheets your ideal drive train on pages 120 et seq.

Input

A	for motor shaft	$L \leq 85$	$24 \leq \varnothing d \leq 48$	result in LA
B	for motor shaft	$85 < L \leq 115$	$48 < \varnothing d \leq 55$	result in LB

Output

0	Optional	3
----------	----------	----------

		I-stage	2-stage	3-stage
LA	[mm]	229	300	371
LB	[mm]	259	330	

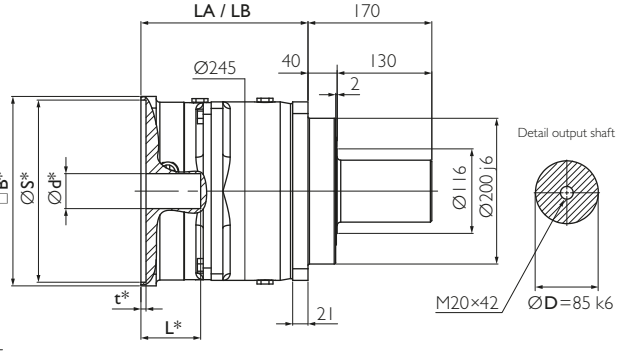
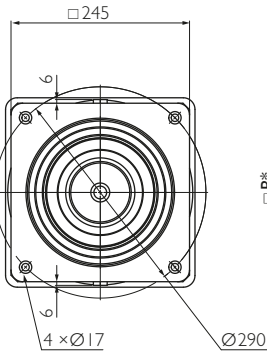
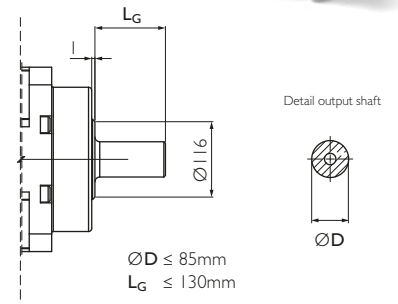

Option 3 on request. Adjustments can reduce capacity.

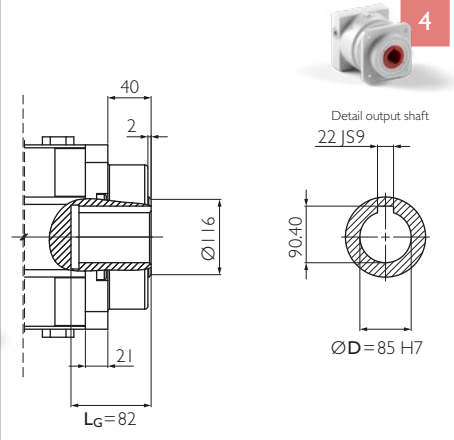

Example NR 240 A0, 1-stage

* depending on the motor. See pages 130 et seq.

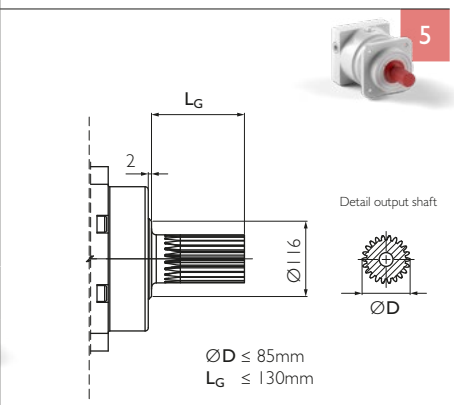
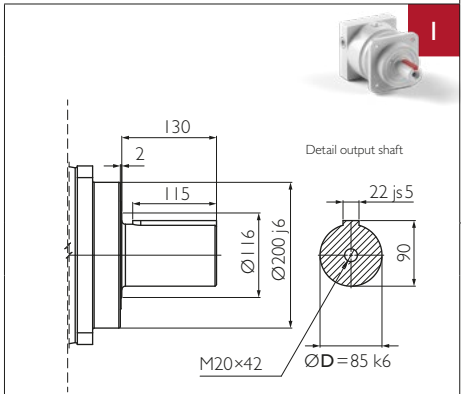

Option 5 on request. Adjustments can reduce capacity.

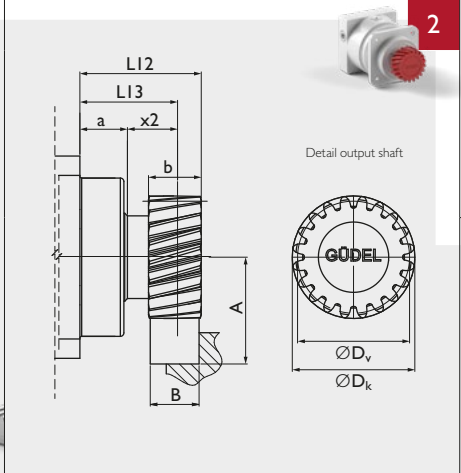

Material 16MnCr5 DIN 1.7131
 Teeth pressure angle $\alpha = 20^\circ$, helical teeth left, 19°31'42" hardened (58⁺⁴ HRC), ground, crowned
 Quality 6f24 DIN 3962 / 63 / 67

Your ideal drive train

Function Package with gearbox, rack and pinion from Güdel

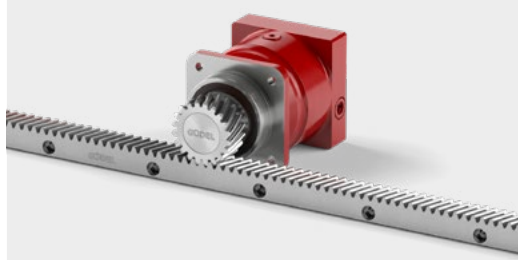

Pinion

	m_n	P_t	z	A	b	D_k	D_0	D_v	L12	L13	x2	a	M
Pinion 1	[-]	5	16.66	24	97.662	50	137.32	127.324	112.5	87.5	47.5	40	5.4
Pinion 2	[-]	6	20.00	20	106.662	60	139.32	127.324	111.0	81.0	41.0	40	5.6

m_n : Normal module, P_t : Transverse pitch [mm], z : Number of teeth, D_0 : Pitch circle diameter for calculation, D_v : Pitch circle diameter for design, M: Weight [kg]

Available ratios	i		I-stage					
			3	4	5	7	10	
Nominal torque S5 ^{a)}	T _{2N}	[Nm]	2 400	2 700	2 700	2 500	1 700	
Acceleration torque S5 ^{b)}	T _{2B}	[Nm]	3 400	3 800	3 800	3 600	2 400	
Nominal input speed S5 ^{c)}	n _{1N}	[rpm]	1 000	1 000	1 000	1 500	1 500	
Maximum input speed S5	n _{1max}	[rpm]	2 000	2 200	2 200	2 200	2 200	
Nominal torque S1 ^{a)}	T _{2N}	[Nm]	1 400	1 600	1 600	1 600	1 600	
Acceleration torque S1 ^{b)}	T _{2B}	[Nm]	1 750	1 750	1 750	1 750	1 750	
Nominal input speed S1 ^{c)}	n _{1N}	[rpm]	700	900	900	1 350	1 350	
Maximum input speed S1	n _{1max}	[rpm]	1 000	1 000	1 000	1 500	1 500	
Emergency stop torque ^{d)}	T _{2not}	[Nm]	6 900	8 500	8 500	8 500	6 800	
Efficiency	η	[%]	97					
Lifetime	L _h	[h]	> 20 000					
Weight	M	[kg]	70					
Angular backlash	j _t	[arcmin]	Precision P I ≤ 1 / P 3 ≤ 3 / P 5 ≤ 5 / P I2 ≤ 12					
Torsionnal rigidity ^{e)}	C _{t2}	[Nm/arcmin]	626	684	698	728	698	
Noise ⁱ⁾	L _{pA}	[dB(A)]	≤ 72					
Max. permitted housing temperature ^{g)}	T	[°C]	90					
Protection class			IP 65					
Direction of rotation			Motor way					
Max. radial force on output shaft ^{f)}	F _{Rmax}	[N]	Center of output shaft: 30 000 / End of output shaft: 20 000					
Max. axial force on output shaft ^{f)}	F _{Amax}	[N]	34 000					
Color			Red, RAL 3003					
Inertia in kg.cm ² ^{h)}	Ø24	J ₁	[kgcm ²]	151.00	83.30	58.00	36.80	24.30
	Ø32			153.20	85.50	60.20	39.00	26.50
	Ø35			158.50	90.80	65.50	44.30	31.80
	Ø38			161.90	94.20	68.90	47.70	35.20
	Ø42			161.40	93.70	68.40	47.20	34.70
	Ø48			161.60	93.90	68.60	47.40	34.90
	Ø55			184.20	116.50	91.20	70.00	57.50

- a) Nominal output torque when operating at n_{1N}.
- b) 1 000 cycles per hour max.
- c) Valid for an ambient temperature of 20°C and T_{2N}. At higher ambient temperatures, please reduce speed.
- d) Valid 1 000 times the gear box life.

- e) Valid for an input Ø of 55 mm in 1-stage and 48 mm in 2- and 3-stage.
- f) Values for 300 rpm.
- g) For other temperatures, please contact us. Nominal output torque when operating at n_{1N}.
- h) Depending on the motor output shaft Ø.
- i) With i=10 and n_{1N}=2000 rpm no load.

Rack



	F _{2B}	[N]	Pinion 1			Pinion 2		
			Q6	Q7	Q9	Q6	Q7	Q9
Max acceleration force	F _{2B}	[N]	44 786	29 748	39 992	63 300	-	59 005
Max acceleration torque	T _{2B}	[Nm]	2 851	1 894	2 546	4 030	-	3 756
Precision			PI		PI2	PI		PI2
Feed force			High	Medium	Elevated	High	Medium	Elevated

Above values for rack and pinion take into consideration a number of load cycles: 1x10⁶ for the rack; 1x10⁷ for the pinion. Both in pulsating operation.

For proper sizing follow flowchart calculate your ideal drive train on pages 136 et seq.

More on the technical datasheets your ideal drive train on pages 120 et seq.

Input

A	for motor shaft	$L \leq 85$	$24 \leq \varnothing d \leq 48$	result in LA
B	for motor shaft	$85 < L \leq 115$	$48 < \varnothing d \leq 55$	result in LB

Output

0	Optional	3
----------	----------	----------

		1-stage	2-stage	3-stage
LA	[mm]	229	300	371
LB	[mm]	259	330	

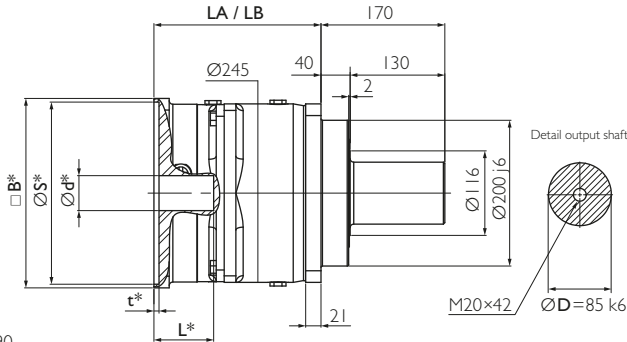
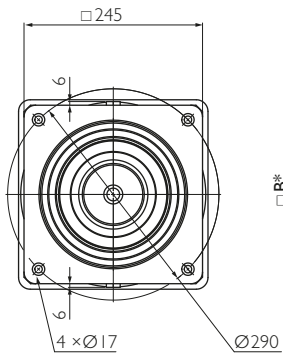

* depending on the motor. See pages 130 et seq.

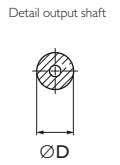
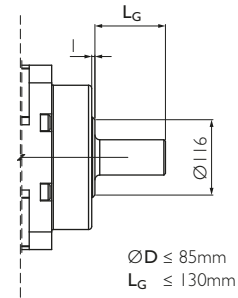

Option 3 on request. Adjustments can reduce capacity.

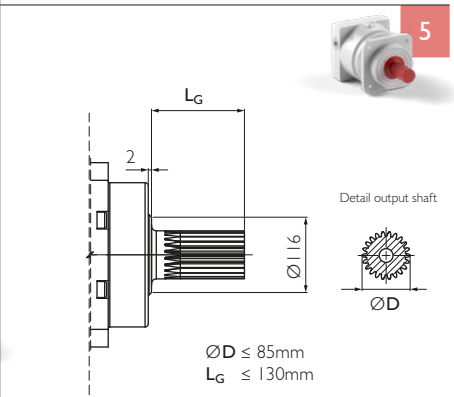
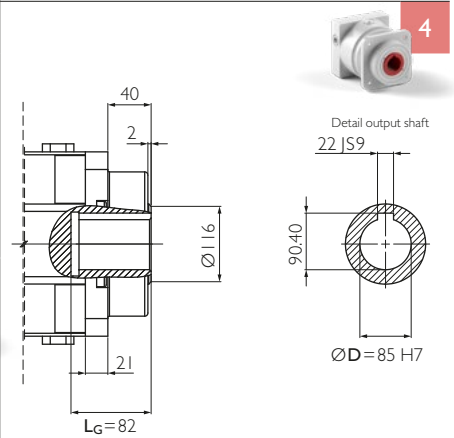

Option 5 on request. Adjustments can reduce capacity.



Example NR 240 A1, 1-stage

Your ideal drive train

Function Package with gearbox, rack and pinion from Güdel

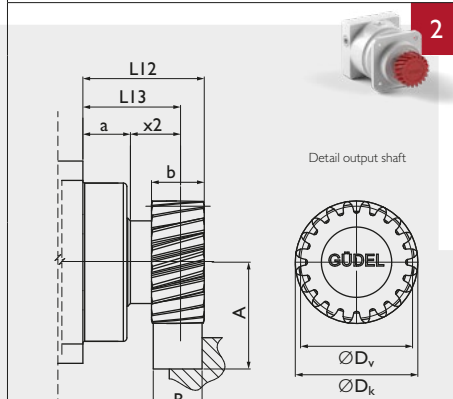
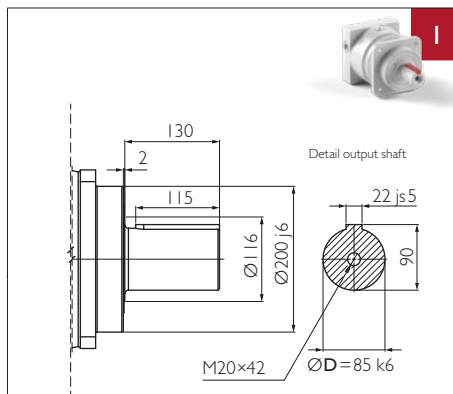
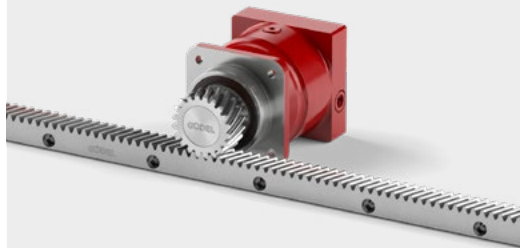

Material 16MnCr5 DIN 1.7131
 Teeth pressure angle $\alpha = 20^\circ$, helical teeth left, 19°31'42" hardened (58⁺⁴ HRC), ground, crowned
 Quality 6f24 DIN 3962 / 63 / 67

Pinion

	m_n	P_t	z	A	b	D_k	D_0	D_v	L12	L13	x2	a	M
Pinion 1	[-]	5	16.66	24	97.662	50	137.32	127.324	112.5	87.5	47.5	40	5.4
Pinion 2	[-]	6	20.00	20	106.662	60	139.32	127.324	111.0	81.0	41.0	40	5.6

m_n : Normal module, P_t : Transverse pitch [mm], z : Number of teeth, D_0 : Pitch circle diameter for calculation, D_v : Pitch circle diameter for design, M: Weight [kg]

Available ratios *	i		2-stage										
			12	16	20	25	30	35	40	50	70	100	
Nominal torque S5 ^{a)}	T _{2N}	[Nm]	2 400	2 700	2 700	2 700	2 400	2 700	2 700	2 700	2 500	1 700	
Acceleration torque S5 ^{b)}	T _{2B}	[Nm]	3 200	3 800	3 800	3 800	3 200	3 800	3 800	3 800	3 600	2 200	
Nominal input speed S5 ^{c)}	n _{1N}	[rpm]	1 700	1 900	1 900	1 900	1 900	1 900	1 900	2 100	2 100	2 400	
Maximum input speed S5	n _{1max}	[rpm]	3 500	3 500	3 500	3 500	3 500	3 500	3 500	3 500	3 500	3 500	
Nominal torque S1 ^{a)}	T _{2N}	[Nm]	1 600	1 600	1 600	1 600	1 600	1 600	1 600	1 600	1 600	1 600	
Acceleration torque S1 ^{b)}	T _{2B}	[Nm]	1 750	1 750	1 750	1 750	1 750	1 750	1 750	1 750	1 750	1 750	
Nominal input speed S1 ^{c)}	n _{1N}	[rpm]	1 200	1 700	1 700	1 700	1 700	1 700	1 700	1 900	1 900	2 100	
Maximum input speed S1	n _{1max}	[rpm]	1 700	1 900	1 900	1 900	1 900	1 900	1 900	2 100	2 100	2 400	
Emergency stop torque ^{d)}	T _{2not}	[Nm]	6 900	8 500	8 500	8 500	6 900	8 500	8 500	8 500	8 500	6 800	
Efficiency	η	[%]	94										
Lifetime	L _h	[h]	> 20 000										
Weight	M	[kg]	90										
Angular backlash	j _t	[arcmin]	Precision P 1 ≤ 1 / P 3 ≤ 3 / P 5 ≤ 5 / P 12 ≤ 12										
Torsionnal rigidity ^{e)}	C _{t2}	[Nm/arcmin]	564.5	582.0	599.5	599.5	564.5	599.5	582.0	599.5	587.8	564.5	
Noise ⁱ⁾	L _{pA}	[dB(A)]	≤ 72										
Max. permitted housing temperature ^{g)}	T	[°C]	90										
Protection class			IP 65										
Direction of rotation			Same way input / output										
Max. radial force on output shaft ^{f)}	F _{Rmax}	[N]	Center of output shaft: 30 000 / End of output shaft: 20 000										
Max. axial force on output shaft ^{f)}	F _{Amax}	[N]	34 000										
Color			Red, RAL 3003										
Inertia in kg.cm ² ^{h)}	Ø24	J ₁	[kg.cm ²]	79.1	74.9	73.3	51.5	23.6	33.5	22.9	22.7	22.4	22.3
	Ø32			81.3	77.1	75.5	53.7	25.8	35.7	25.1	24.9	24.6	24.5
	Ø35			86.6	82.4	80.8	59	31.1	41	30.4	30.2	29.9	29.8
	Ø38			90	85.8	84.2	62.4	34.5	44.4	33.8	33.6	33.3	33.2
	Ø42			89.5	85.3	83.7	61.9	34	43.9	33.3	33.1	32.8	32.7
	Ø48			89.7	85.5	83.9	62.1	34.2	44.1	33.5	33.3	33	32.9
	Ø55			112.3	108.1	106.5	84.7	56.8	66.7	56.1	55.9	55.6	55.5

* Other ratios available. 9, 15, 21, 27, 28, 49 on request.

a) Nominal output torque when operating at n_{1N}.

b) 1 000 cycles per hour max.

c) Valid for an ambient temperature of 20°C and T_{2N}.

At higher ambient temperatures, please reduce speed.

d) Valid 1 000 times the gearbox life.

e) Valid for an input Ø of 55 mm in 1-stage and 48 mm in 2- and 3-stage.

f) Values for 300 rpm.

g) For other temperatures, please contact us. Nominal output torque when operating at n_{1N}.

h) Depending on the motor output shaft Ø.

i) With i=10 and n_{1N}=2000 rpm no load.

Rack



			Pinion 1			Pinion 2		
			Q6	Q7	Q9	Q6	Q7	Q9
Max acceleration force	F _{2B}	[N]	44 786	29 748	39 992	63 300	-	59 005
Max acceleration torque	T _{2B}	[Nm]	2 851	1 894	2 546	4 030	-	3 756
Precision			PI		P12	PI		P12
Feed force			High	Medium	Elevated	High	Medium	Elevated

Above values for rack and pinion take into consideration a number of load cycles: 1x10⁶ for the rack; 1x10⁷ for the pinion. Both in pulsating operation.

For proper sizing follow flowchart calculate your ideal drive train on pages 136 et seq.

More on the technical datasheets your ideal drive train on pages 120 et seq.

Input

A	for motor shaft	$L \leq 85$	$24 \leq \varnothing d \leq 48$	result in LA
B	for motor shaft	$85 < L \leq 115$	$48 < \varnothing d \leq 55$	result in LB

Output

0	Standard	3	Optional
----------	----------	----------	----------

		1-stage	2-stage	3-stage
LA	[mm]	229	300	371
LB	[mm]	259	330	

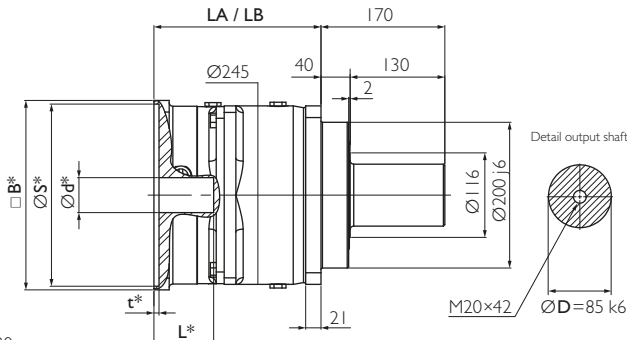
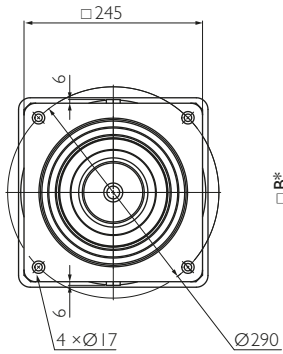

* depending on the motor. See pages 130 et seq.



Example NR 240 A2, 1-stage

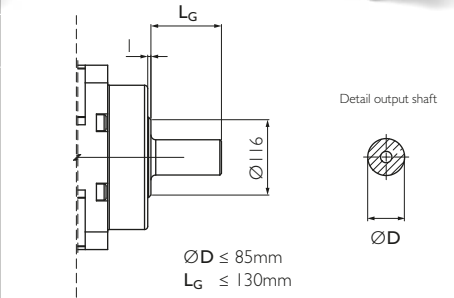

Option 3 on request. Adjustments can reduce capacity.

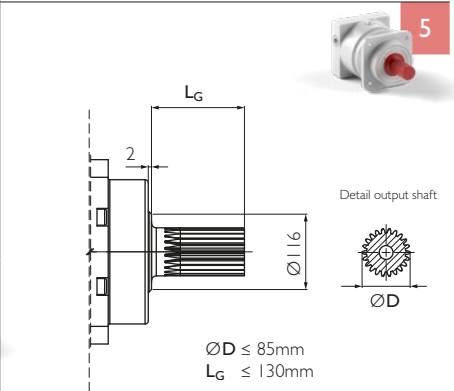
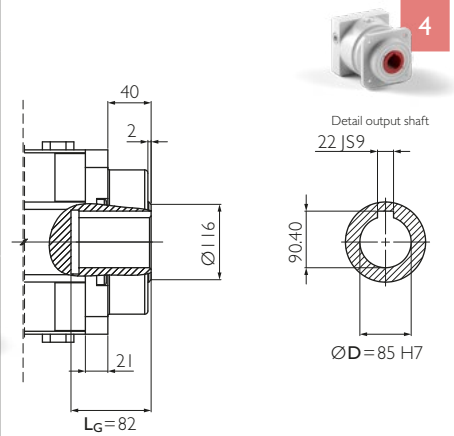

Option 5 on request. Adjustments can reduce capacity.

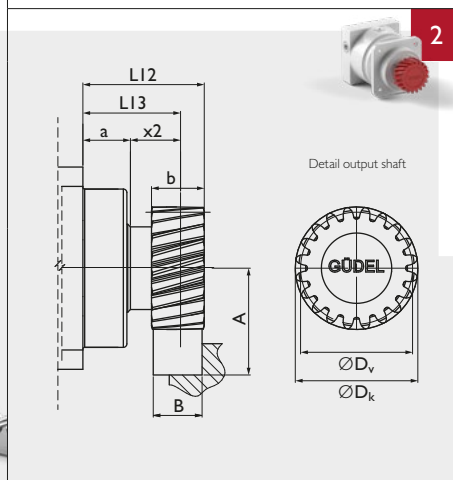
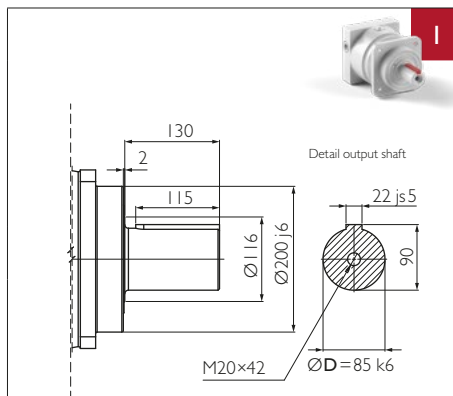

Your ideal drive train

Function Package with gearbox, rack and pinion from Güdel

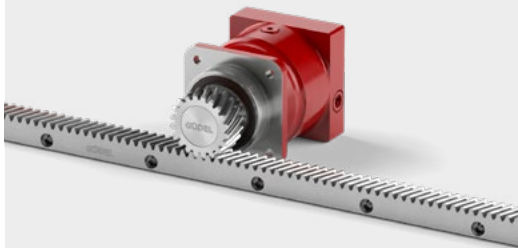

Material 16MnCr5 DIN 1.7131
 Teeth pressure angle $\alpha = 20^\circ$, helical teeth left, $19^\circ 31' 42''$ hardened (58⁺⁴ HRC), ground, crowned
 Quality 6f24 DIN 3962 / 63 / 67

Pinion

	m_n	P_t	z	A	b	D_k	D_0	D_v	L12	L13	x2	a	M
Pinion 1	[-]	5	16.66	24	97.662	50	137.32	127.324	112.5	87.5	47.5	40	5.4
Pinion 2	[-]	6	20.00	20	106.662	60	139.32	127.324	111.0	81.0	41.0	40	5.6

m_n : Normal module, P_t : Transverse pitch [mm], z : Number of teeth, D_0 : Pitch circle diameter for calculation, D_v : Pitch circle diameter for design, M: Weight [kg]

Available ratios *	i		3-stage										
			105	125	175	200	250	300	400	500	700	1 000	
Nominal torque S5 ^{a)}	T _{2N}	[Nm]	2 700	2 700	2 700	2 700	2 700	2 400	2 700	2 700	2 500	1 500	
Acceleration torque S5 ^{b)}	T _{2B}	[Nm]	3 800	3 800	3 800	3 800	3 800	3 000	3 800	3 800	3 600	2 200	
Nominal input speed S5 ^{c)}	n _{1N}	[rpm]	2 400	2 400	2 400	2 400	2 400	2 400	2 400	2 400	2 400	2 400	
Maximum input speed S5	n _{1max}	[rpm]	3 500	3 500	3 500	3 500	3 500	3 500	3 500	3 500	3 500	3 500	
Nominal torque S1 ^{a)}	T _{2N}	[Nm]	1 600	1 600	1 600	1 600	1 600	1 600	1 600	1 600	1 600	1 600	
Acceleration torque S1 ^{b)}	T _{2B}	[Nm]	1 750	1 750	1 750	1 750	1 750	1 750	1 750	1 750	1 750	1 750	
Nominal input speed S1 ^{c)}	n _{1N}	[rpm]	2 100	2 100	2 100	2 100	2 100	2 100	2 100	2 100	2 100	2 100	
Maximum input speed S1	n _{1max}	[rpm]	2 400	2 400	2 400	2 400	2 400	2 400	2 400	2 400	2 400	2 400	
Emergency stop torque ^{d)}	T _{2not}	[Nm]	8 500	8 500	8 500	8 500	8 500	6 900	8 500	8 500	8 500	6 800	
Efficiency	η	[%]	91										
Lifetime	L _h	[h]	> 20 000										
Weight	M	[kg]	110										
Angular backlash	j _t	[arcmin]	Precision P I ≤ 1 / P 3 ≤ 3 / P 5 ≤ 5 / P I2 ≤ 12										
Torsionnal rigidity ^{e)}	C _{t2}	[Nm/arcmin]	538	538	538	538	538	506	524	538	556	524	
Noise ⁱ⁾	L _{pA}	[dB(A)]	≤ 72										
Max. permitted housing temperature ^{g)}	T	[°C]	90										
Protection class			IP 65										
Direction of rotation			Same way input / output										
Max. radial force on output shaft ^{f)}	F _{Rmax}	[N]	Center of output shaft: 30 000 / End of output shaft: 20 000										
Max. axial force on output shaft ^{f)}	F _{Amax}	[N]	34 000										
Color			Red, RAL 3003										
Inertia in kg.cm ² ^{h)}	Ø24	J ₁	[kgcm ²]	35.10	51.30	35.10	22.80	22.60	22.30	22.30	22.30	22.30	
	Ø32			37.30	53.50	37.30	25.00	24.80	24.50	24.50	24.50	24.50	24.50
	Ø35			42.60	58.80	42.60	30.30	30.10	29.80	29.80	29.80	29.80	29.80
	Ø38			46.00	62.20	46.00	33.70	33.50	33.20	33.20	33.20	33.20	33.20
	Ø42			45.50	61.70	45.50	33.20	33.00	32.70	32.70	32.70	32.70	32.70
	Ø48			45.70	61.70	45.70	33.40	33.20	32.90	32.90	32.90	32.90	32.90
	Ø55			68.30	84.50	68.30	56.00	55.80	55.50	55.50	55.50	55.50	55.50

- * Other ratios available. 112, 120, 140, 147, 150, 160, 196, 210, 245, 280, 343, 350, 490 on request.
- a) Nominal output torque when operating at n_{1N}.
- b) 1000 cycles per hour max.
- c) Valid for an ambient temperature of 20°C and T_{2N}. At higher ambient temperatures, please reduce speed.

- d) Valid 1000 times the gearbox life.
- e) Valid for an input Ø of 55 mm in 1-stage and 48 mm in 2- and 3-stage.
- f) Values for 300 rpm.
- g) For other temperatures, please contact us. Nominal output torque when operating at n_{1N}.
- h) Depending on the motor output shaft Ø.
- i) With i=10 and n_{1N}=2000 rpm no load.

Rack



			Pinion 1			Pinion 2		
			Q6	Q7	Q9	Q6	Q7	Q9
Max acceleration force	F _{2B}	[N]	44 786	29 748	39 992	63 300	-	59 005
Max acceleration torque	T _{2B}	[Nm]	2 851	1 894	2 546	4 030	-	3 756
Precision			PI		P12	PI		P12
Feed force			High	Medium	Elevated	High	Medium	Elevated

For proper sizing follow flowchart calculate your ideal drive train on pages 136 et seq.

More on the technical datasheets your ideal drive train on pages 120 et seq.

Above values for rack and pinion take into consideration a number of load cycles: 1x10⁶ for the rack; 1x10⁷ for the pinion. Both in pulsating operation.

Input

A	for motor shaft	$L \leq 45$	$6 \leq \varnothing d \leq 19$	result in LA
B	for motor shaft	$45 < L \leq 55$	$19 < \varnothing d \leq 24$	result in LB

		1-stage	2-stage	3-stage
LA	[mm]	106.5	128.5	150.5
LB	[mm]	116	138	160

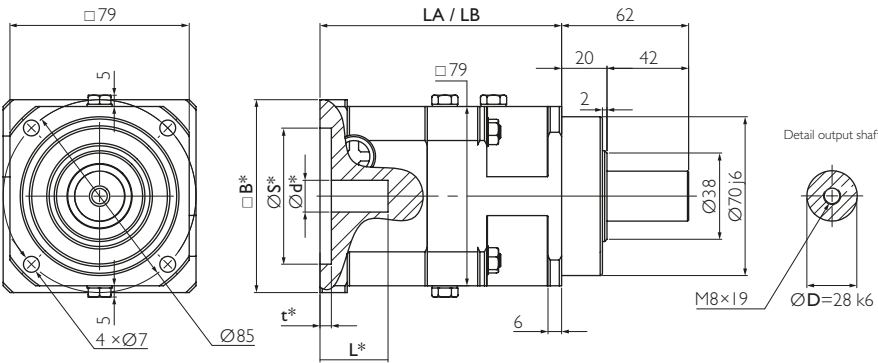

* depending on the motor. See pages 130 et seq.

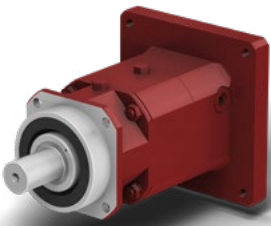

Example SR 080 B0, 2-stage

Output

0	3
----------	----------

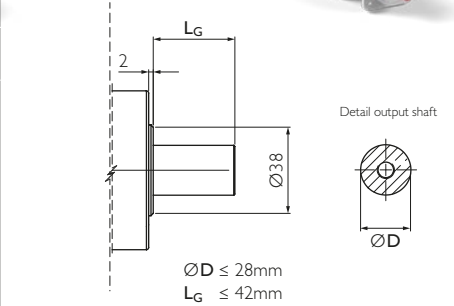

Option 3 on request. Adjustments can reduce capacity.

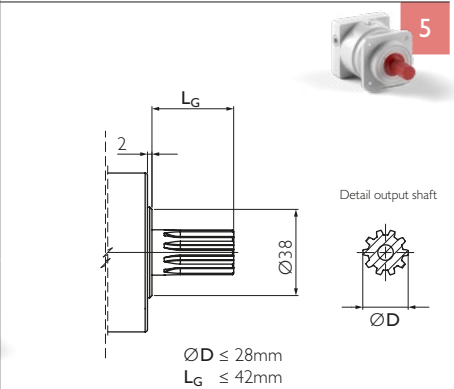
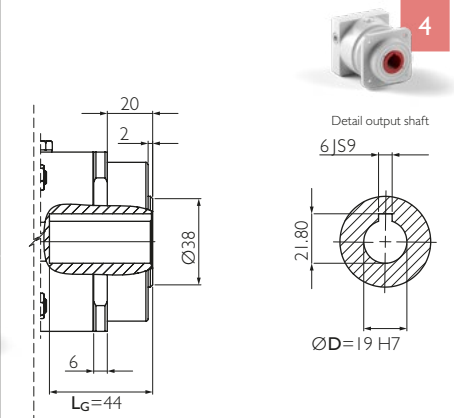

Option 5 on request. Adjustments can reduce capacity.

Your ideal drive train

Function Package with gearbox, rack and pinion from Güdel

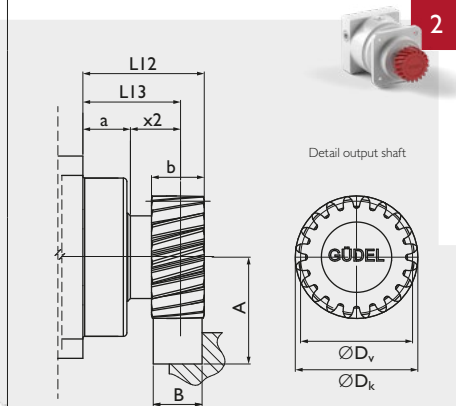
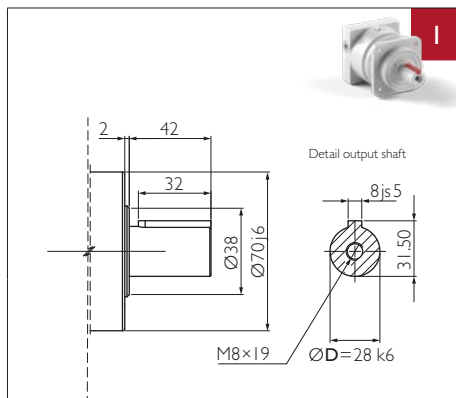
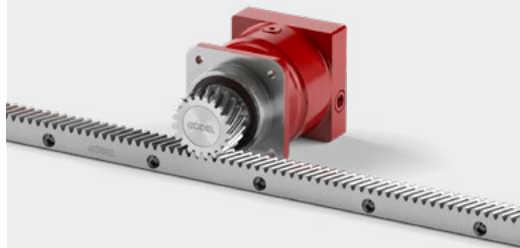

Material 16MnCr5 DIN 1.7131
 Teeth pressure angle $\alpha = 20^\circ$, helical teeth left, $19^\circ 31' 42''$ hardened (58⁺⁴ HRC), ground, crowned
 Quality 6f24 DIN 3962 / 63 / 67

Pinion

	m_n	P_t	z	A	b	D_k	D_0	D_v	L12	L13	x2	a	M	
Pinion 1	[-]	2	6.66	20	43.221	25	46.44	42.441	42.441	52.5	40.0	20.0	20	0.3
Pinion 2	[-]	2.5	8.33	16	43.471	26	48.94	42.441	43.941	58	45	15	30	0.3

m_n : Normal module, P_t : Transverse pitch [mm], z : Number of teeth, D_0 : Pitch circle diameter for calculation, D_v : Pitch circle diameter for design, M: Weight [kg]

Available ratios	i		1-stage		2-stage				
			4	12	16	20	28	40	
Nominal torque S5 ^{a)}	T _{2N}	[Nm]	95	95	95	95	95	95	
Acceleration torque S5 ^{b)}	T _{2B}	[Nm]	150	140	140	140	140	140	
Nominal input speed S5 ^{c)}	n _{1N}	[rpm]	2 600	2 900	3 100	3 100	3 100	3 100	
Maximum input speed S5	n _{1max}	[rpm]	5 400	5 400	5 400	5 400	5 400	5 400	
Emergency stop torque ^{d)}	T _{2not}	[Nm]	250	250	250	250	250	250	
Efficiency	η	[%]	96	93					
Lifetime	L _h	[h]	> 20 000						
Weight	M	[kg]	4	5					
Angular backlash	j _t	[arcmin]	Precision P I ≤ 1 / P 3 ≤ 3 / P 5 ≤ 5 / P 12 ≤ 12						
Torsionnal rigidity ^{e)}	C _{t2}	[Nm/arcmin]	11.7	11.1	11.1	11.3	11.1	11.1	
Noise ⁱ⁾	L _{pA}	[dB(A)]	≤ 70						
Max. permitted housing temperature ^{g)}	T	[°C]	90						
Protection class			IP 65						
Direction of rotation			Same way input / output						
Max. radial force on output shaft ^{f)}	F _{rmax}	[N]	Center of output shaft: 4 200 / End of output shaft: 3 285						
Max. axial force on output shaft ^{f)}	F _{amax}	[N]	3 600						
Color			Red, RAL 3003						
Inertia in kg·cm ² ^{h)}	Ø11	J ₁	[kgcm ²]	0.46	0.46	0.45	0.45	0.34	0.31
	Ø14			1.02	1.01	1.00	1.00	0.89	0.86
	Ø19			1.03	1.03	1.02	1.01	0.91	0.88
	Ø24			1.85	1.84	1.83	1.83	1.72	1.69

- a) Nominal output torque when operating at n_{1N}.
b) 1000 cycles per hour max.
c) Valid for an ambient temperature of 20°C and T_{2N}.
At higher ambient temperatures, please reduce speed.
d) Valid 1000 times the gearbox life.

- e) Valid for an input Ø of 19mm in 1-stage and 14mm in 2- and 3-stage.
f) Values for 300 rpm.
g) For other temperatures, please contact us. Nominal output torque when operating at n_{1N}.
h) Depending on the motor output shaft Ø.
i) With i=10 and n_{1N}=2500 rpm no load.

Rack



	F _{2B}	[N]	Pinion 1			Pinion 2		
			Q6	Q7	Q9	Q6	Q7	Q9
Max acceleration force	F _{2B}	[N]	7 490	2 963	5 036	7 490	2 963	5 036
Max acceleration torque	T _{2B}	[Nm]	159	63	107	159	63	107
Precision			PI		P12	PI		P12
Feed force			High	Medium	Elevated	High	Medium	Elevated

Above values for rack and pinion take into consideration a number of load cycles:
1x10⁶ for the rack; 1x10⁷ for the pinion. Both in pulsating operation.

For proper sizing follow flowchart
calculate your ideal drive train
on pages 136 et seq.

More on the technical datasheets
your ideal drive train on pages
120 et seq.

Input

A	for motor shaft	$L \leq 45$	$6 \leq \varnothing d \leq 19$	result in LA
B	for motor shaft	$45 < L \leq 55$	$19 < \varnothing d \leq 24$	result in LB

Output

Standard

Optional

		1-stage	2-stage	3-stage
LA	[mm]	106.5	128.5	150.5
LB	[mm]	116	138	160

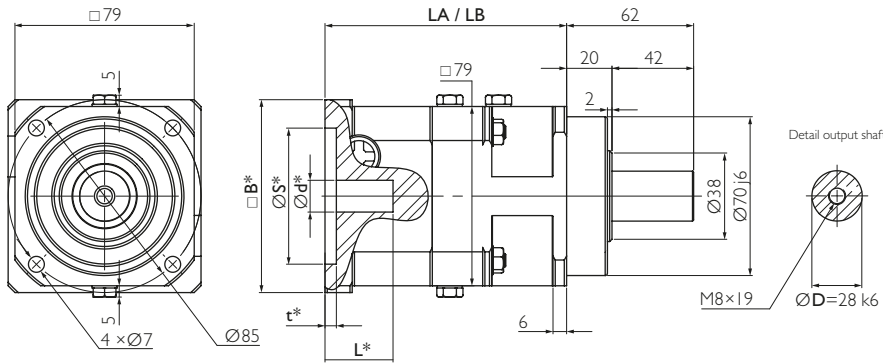

* depending on the motor. See pages 130 et seq.



Example SR 080 A1, 3-stage

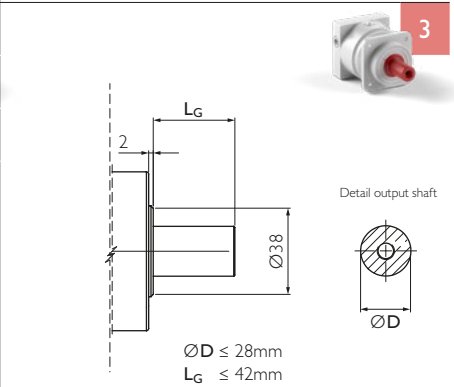

Option 3 on request. Adjustments can reduce capacity.

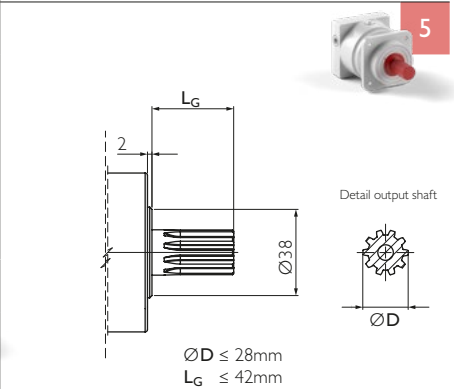
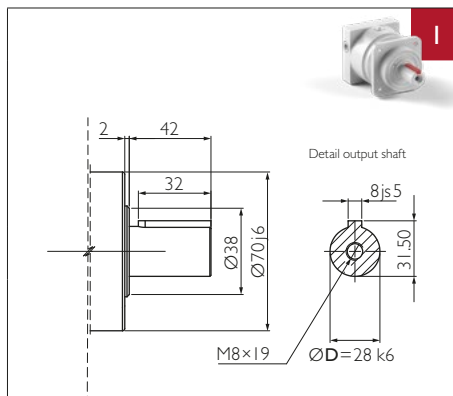
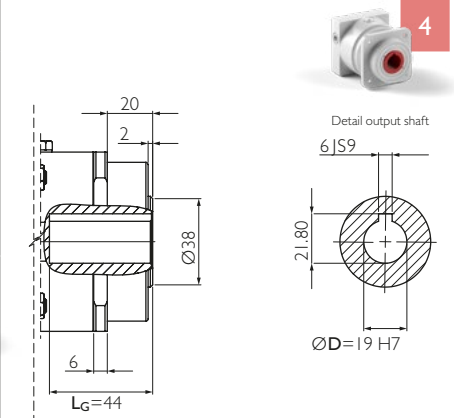

Option 5 on request. Adjustments can reduce capacity.

Your ideal drive train

Function Package with gearbox, rack and pinion from Güdel

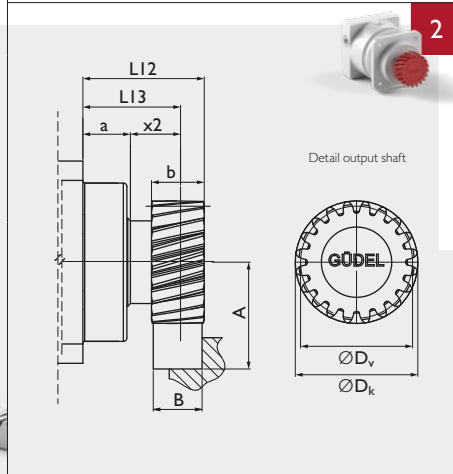
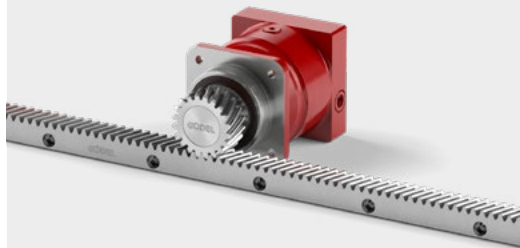

Pinion

	m_n	P_t	z	A	b	D_k	D_0	D_v	L12	L13	x2	a	M	
Pinion 1	[-]	2	6.66	20	43.221	25	46.44	42.441	42.441	52.5	40.0	20.0	20	0.3
Pinion 2	[-]	2.5	8.33	16	43.471	26	48.94	42.441	43.941	58	45	15	30	0.3

m_n : Normal module, P_t : Transverse pitch [mm], z : Number of teeth, D_0 : Pitch circle diameter for calculation, D_v : Pitch circle diameter for design, M: Weight [kg]

Available ratios	i		3-stage										
			60	80	100	112	120	140	160	200	280	400	
Nominal torque S5 ^{a)}	T _{2N}	[Nm]	95	95	95	95	95	95	95	95	95	95	95
Acceleration torque S5 ^{b)}	T _{2B}	[Nm]	140	140	140	140	140	140	140	140	140	140	140
Nominal input speed S5 ^{c)}	n _{1N}	[rpm]	4 000	4 000	4 000	4 000	4 000	4 000	4 000	4 000	4 000	4 000	4 000
Maximum input speed S5	n _{1max}	[rpm]	5 400	5 400	5 400	5 400	5 400	5 400	5 400	5 400	5 400	5 400	5 400
Emergency stop torque ^{d)}	T _{2not}	[Nm]	250	250	250	250	250	250	250	250	250	250	250
Efficiency	η	[%]	90										
Lifetime	L _h	[h]	> 20 000										
Weight	M	[kg]	6										
Angular backlash	j _t	[arcmin]	Precision P 1 ≤ 1 / P 3 ≤ 3 / P 5 ≤ 5 / P 12 ≤ 12										
Torsionnal rigidity ^{e)}	C _{t2}	[Nm/arcmin]	10.7	10.7	9.8	10.6	10.6	10.7	10.6	10.7	10.6	10.7	10.1
Noise ⁱ⁾	L _{pA}	[dB(A)]	≤ 70										
Max. permitted housing temperature ^{g)}	T	[°C]	90										
Protection class			IP 65										
Direction of rotation			Same way input / output										
Max. radial force on output shaft ^{f)}	F _{rmax}	[N]	Center of output shaft: 4 200 / End of output shaft: 3 285										
Max. axial force on output shaft ^{f)}	F _{amax}	[N]	3 600										
Color			Red, RAL 3003										
Inertia in kg.cm ² ^{h)}	Ø 11	J _I	[kgcm ²]	0.46	0.45	0.31	0.34	0.31	0.34	0.31	0.31	0.31	0.31
	Ø 14			1.01	1.00	0.86	0.89	0.86	0.89	0.86	0.86	0.86	0.86
	Ø 19			1.03	1.02	0.88	0.91	0.88	0.91	0.88	0.88	0.88	0.88
	Ø 24			1.84	1.83	1.69	1.72	1.69	1.72	1.69	1.69	1.69	1.69

* Other ratios available. 36, 64, 84, 180, 196, 300, 360, 500, 600, 700, 1 000 on request.

a) Nominal output torque when operating at n_{1N}.

b) 1 000 cycles per hour max.

c) Valid for an ambient temperature of 20°C and T_{2N}.
At higher ambient temperatures, please reduce speed.

d) Valid 1000 times the gearbox life.

e) Valid for an input Ø of 19 mm in 1-stage and 14 mm in 2- and 3-stage.

f) Values for 300 rpm.

g) For other temperatures, please contact us. Nominal output torque when operating at n_{1N}.

h) Depending on the motor output shaft Ø.

i) With i=10 and n_{1N}=2500 rpm no load.

Rack



			Pinion 1			Pinion 2		
			Q6	Q7	Q9	Q6	Q7	Q9
Max acceleration force	F _{2B}	[N]	7 490	2 963	5 036	7 490	2 963	5 036
Max acceleration torque	T _{2B}	[Nm]	159	63	107	159	63	107
Precision			PI		P12	PI		P12
Feed force			High	Medium	Elevated	High	Medium	Elevated

Above values for rack and pinion take into consideration a number of load cycles:
1x10⁶ for the rack; 1x10⁷ for the pinion. Both in pulsating operation.

For proper sizing follow flowchart
calculate your ideal drive train
on pages 136 et seq.

More on the technical datasheets
your ideal drive train on pages
120 et seq.

Input

A	for motor shaft	$L \leq 50$	$9 \leq \varnothing d \leq 24$	result in LA
B	for motor shaft	$51 < L \leq 64$	$24 < \varnothing d \leq 35$	result in LB

		I-stage	2-stage	3-stage
LA	[mm]	126	164	202
LB	[mm]	140	178	216

Output

0	Standard	3	Optional
----------	----------	----------	----------

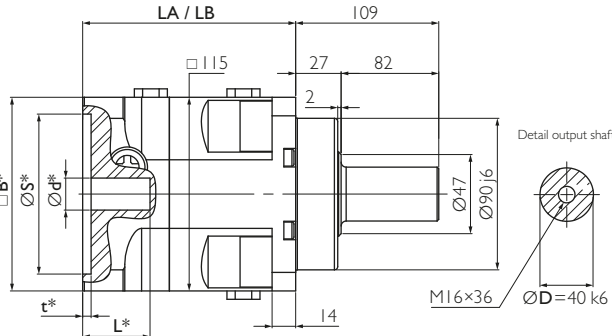
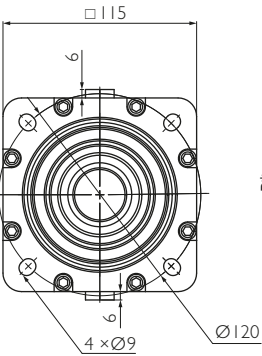

* depending on the motor. See pages 130 et seq.



Example SR 100 A0, 1-stage

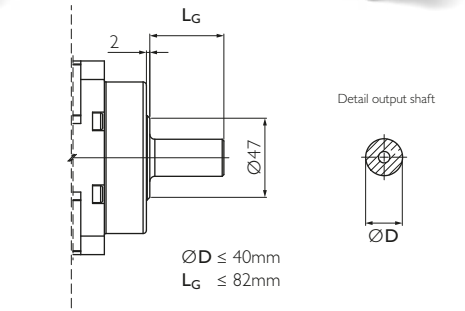

Option 3 on request. Adjustments can reduce capacity.

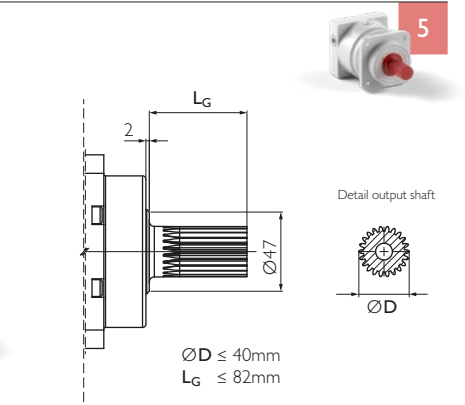
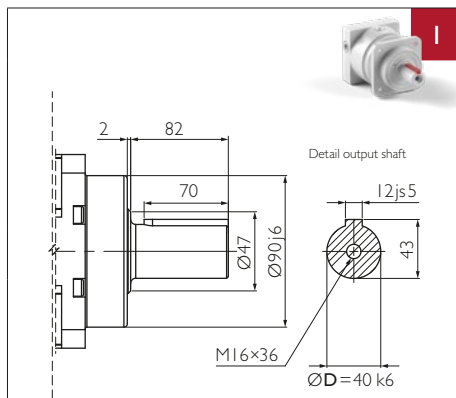
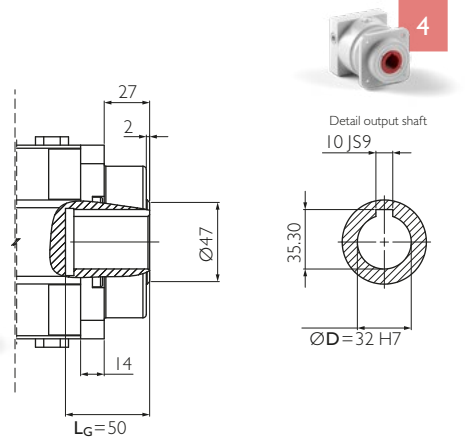

Option 5 on request. Adjustments can reduce capacity.

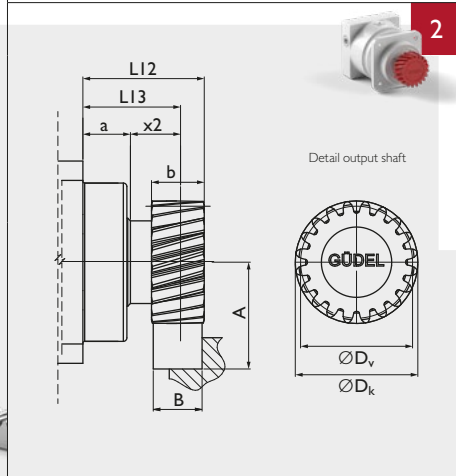

Material 16MnCr5 DIN 1.7131
 Teeth pressure angle $\alpha = 20^\circ$, helical teeth left, $19^\circ 31' 42''$ hardened (58⁺⁴HRC), ground, crowned
 Quality 6f24 DIN 3962 / 63 / 67

Your ideal drive train

Function Package with gearbox, rack and pinion from Güdel

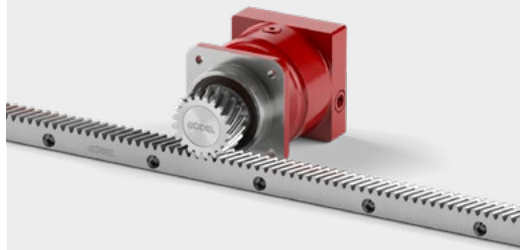

Pinion

	m_n	P_t	z	A	b	D_k	D_0	D_v	L12	L13	x2	a	M	
Pinion 1	[-]	2	6.66	25	48.526	25	57.05	53.052	53.052	63.3	51.0	24.0	27	0.4
Pinion 2	[-]	3	10.00	20	57.831	30	69.66	63.662	63.662	69.0	54.0	27.0	27	0.7

m_n : Normal module, P_t : Transverse pitch [mm], z : Number of teeth, D_0 : Pitch circle diameter for calculation, D_v : Pitch circle diameter for design, M: Weight [kg]

Available ratios	i		1-stage		2-stage				
			4	12	16	20	28	40	
Nominal torque S5 ^{a)}	T _{2N}	[Nm]	300	300	300	300	300	300	
Acceleration torque S5 ^{b)}	T _{2B}	[Nm]	370	370	370	370	370	370	
Nominal input speed S5 ^{c)}	n _{1N}	[rpm]	2 200	2 600	2 800	2 800	2 800	2 800	
Maximum input speed S5	n _{1max}	[rpm]	4 000	4 000	4 000	4 000	4 000	4 000	
Emergency stop torque ^{d)}	T _{2not}	[Nm]	800	800	800	800	800	800	
Efficiency	η	[%]	96	93					
Lifetime	L _h	[h]	> 20 000						
Weight	M	[kg]	8	10					
Angular backlash	j _t	[arcmin]	Precision P I ≤ 1 / P 3 ≤ 3 / P 5 ≤ 5 / P 12 ≤ 12						
Torsionnal rigidity ^{e)}	C _{t2}	[Nm/arcmin]	41.0	32.0	38.7	38.4	36.8	38.7	
Noise ⁱ⁾	L _{pA}	[dB(A)]	≤ 71						
Max. permitted housing temperature ^{g)}	T	[°C]	90						
Protection class			IP 65						
Direction of rotation			Same way input / output						
Max. radial force on output shaft ^{f)}	F _{rmax}	[N]	Center of output shaft: 6 600 / End of output shaft: 4 300						
Max. axial force on output shaft ^{f)}	F _{amax}	[N]	6 000						
Color			Red, RAL 3003						
Inertia in kg·cm ² ^{h)}	Ø14	J ₁	[kg·cm ²]	2.83	2.76	2.69	2.23	1.83	1.60
	Ø19			2.83	2.76	2.69	2.23	1.83	1.60
	Ø24			2.84	2.77	2.70	2.24	1.84	1.61
	Ø32			6.04	5.97	5.90	5.44	5.04	4.81
	Ø35			8.67	8.60	8.53	8.07	7.67	7.44

- a) Nominal output torque when operating at n_{1N}.
b) 1000 cycles per hour max.
c) Valid for an ambient temperature of 20°C and T_{2N}.
At higher ambient temperatures, please reduce speed.
d) Valid 1000 times the gearbox life.

- e) Valid for an input Ø of 24 mm in 1-stage and 19 mm in 2- and 3-stage.
f) Values for 300 rpm.
g) For other temperatures, please contact us. Nominal output torque when operating at n_{1N}.
h) Depending on the motor output shaft Ø.
i) With n_{1N}=2500 rpm no load.

Rack



			Pinion 1			Pinion 2		
			Q6	Q7	Q9	Q6	Q7	Q9
Max acceleration force	F _{2B}	[N]	7 540	4 107	4 805	16 163	7 565	12 980
Max acceleration torque	T _{2B}	[Nm]	200	109	127	515	241	413
Precision			PI		P12	PI		P12
Feed force			High	Medium	Elevated	High	Medium	Elevated

Above values for rack and pinion take into consideration a number of load cycles:
1x10⁶ for the rack; 1x10⁷ for the pinion. Both in pulsating operation.

For proper sizing follow flowchart
calculate your ideal drive train
on pages 136 et seq.

More on the technical datasheets
your ideal drive train on pages
120 et seq.

Input

A	for motor shaft	$L \leq 50$	$9 \leq \varnothing d \leq 24$	result in LA
B	for motor shaft	$51 < L \leq 64$	$24 < \varnothing d \leq 35$	result in LB

		1-stage	2-stage	3-stage
LA	[mm]	126	164	202
LB	[mm]	140	178	216

Output

0		3
----------	--	----------

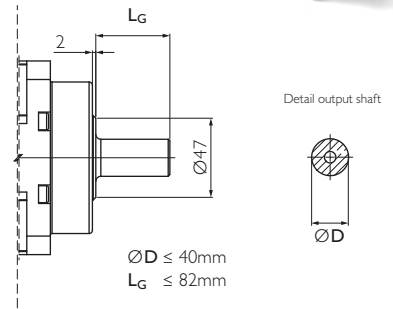

Option 3 on request. Adjustments can reduce capacity.

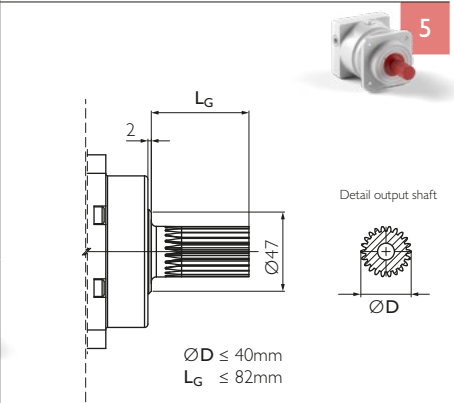
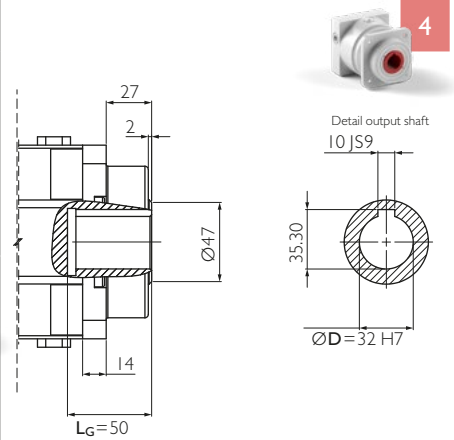

Option 5 on request. Adjustments can reduce capacity.

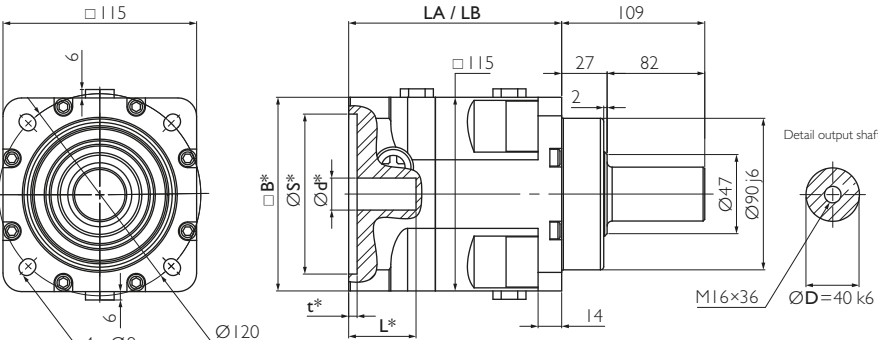

* depending on the motor. See pages 130 et seq.

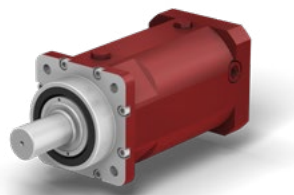
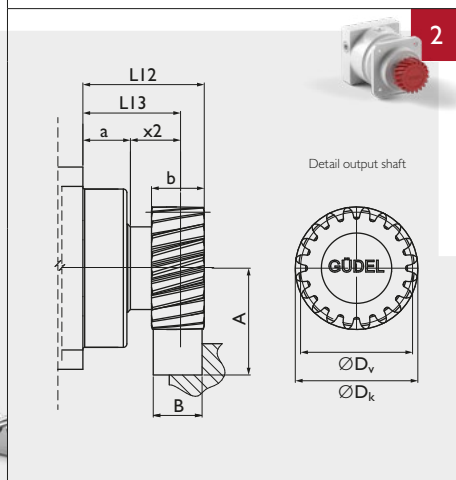
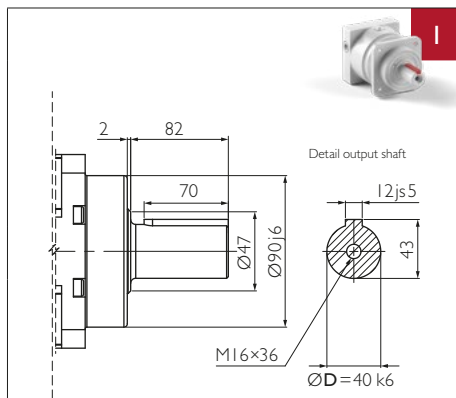

Example SR 100 A0. 3-stage

Your ideal drive train

Function Package with gearbox, rack and pinion from Güdel

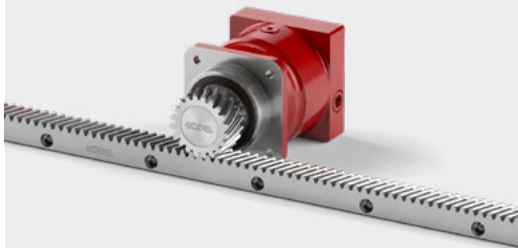

Pinion

	m_n	P_t	z	A	b	D_k	D_0	D_v	L12	L13	x2	a	M	
Pinion 1	[-]	2	6.66	25	48.526	25	57.05	53.052	53.052	63.3	51.0	24.0	27	0.4
Pinion 2	[-]	3	10.00	20	57.831	30	69.66	63.662	63.662	69.0	54.0	27.0	27	0.7

m_n : Normal module, P_t : Transverse pitch [mm], z : Number of teeth, D_0 : Pitch circle diameter for calculation, D_v : Pitch circle diameter for design, M: Weight [kg]

Available ratios *	i		3-stage										
			60	80	100	112	120	140	160	200	280	400	
Nominal torque S5 ^{a)}	T _{2N}	[Nm]	300	300	300	300	300	300	300	300	300	300	
Acceleration torque S5 ^{b)}	T _{2B}	[Nm]	404	404	404	404	404	404	404	404	404	404	
Nominal input speed S5 ^{c)}	n _{1N}	[rpm]	3 800	3 800	3 800	3 800	3 800	3 800	3 800	3 800	3 800	3 800	
Maximum input speed S5	n _{1max}	[rpm]	4 500	4 500	4 500	4 500	4 500	4 500	4 500	4 500	4 500	4 500	
Emergency stop torque ^{d)}	T _{2not}	[Nm]	800	800	800	800	800	800	800	800	800	800	
Efficiency	η	[%]	90										
Lifetime	L _h	[h]	> 20 000										
Weight	M	[kg]	12										
Angular backlash	j _t	[arcmin]	Precision P 1 ≤ 1 / P 3 ≤ 3 / P 5 ≤ 5 / P 12 ≤ 12										
Torsionnal rigidity ^{e)}	C _{t2}	[Nm/arcmin]	38.4	38.4	34.3	37.0	37.0	38.4	37.0	38.4	37.0	37.0	
Noise ⁱ⁾	L _{pA}	[dB(A)]	≤ 71										
Max. permitted housing temperature ^{g)}	T	[°C]	90										
Protection class			IP 65										
Direction of rotation			Same way input / output										
Max. radial force on output shaft ^{f)}	F _{rmax}	[N]	Center of output shaft: 6 600 / End of output shaft: 4 300										
Max. axial force on output shaft ^{f)}	F _{amax}	[N]	6 000										
Color			Red, RAL 3003										
Inertia in kg·cm ² ^{h)}	Ø14	J ₁	[kgcm ²]	2.23	2.22	1.59	1.83	1.59	1.82	1.60	1.59	1.59	1.59
	Ø19			2.23	2.22	1.59	1.83	1.59	1.82	1.60	1.59	1.59	1.59
	Ø24			2.24	2.23	1.60	1.84	1.61	1.83	1.61	1.60	1.60	1.60
	Ø32			5.44	5.43	4.80	5.04	4.80	5.03	4.81	4.80	4.80	4.80
	Ø35			8.07	8.06	7.43	7.67	7.44	7.66	7.44	7.43	7.43	7.43

* Other ratios available. 36, 64, 84, 180, 196, 300, 360, 500, 600, 700, 1000 on request.

a) Nominal output torque when operating at n_{1N}.

b) 1000 cycles per hour max.

c) Valid for an ambient temperature of 20°C and T_{2N}.
At higher ambient temperatures, please reduce speed.

d) Valid 1000 times the gearbox life.

e) Valid for an input Ø of 24 mm in 1-stage and 19 mm in 2- and 3-stage.

f) Values for 300 rpm.

g) For other temperatures, please contact us. Nominal output torque when operating at n_{1N}.

h) Depending on the motor output shaft Ø.

i) With n_{1N}=2500 rpm no load.

Rack



			Pinion 1			Pinion 2		
			Q6	Q7	Q9	Q6	Q7	Q9
Max acceleration force	F _{2B}	[N]	7 540	4 107	4 805	16 163	7 565	12 980
Max acceleration torque	T _{2B}	[Nm]	200	109	127	515	241	413
Precision			PI		P12	PI		P12
Feed force			High	Medium	Elevated	High	Medium	Elevated

Above values for rack and pinion take into consideration a number of load cycles:
1x10⁶ for the rack; 1x10⁷ for the pinion. Both in pulsating operation.

For proper sizing follow flowchart
calculate your ideal drive train
on pages 136 et seq.

More on the technical datasheets
your ideal drive train on pages
120 et seq.

Input

A	for motor shaft	$L \leq 51$	$14 \leq \varnothing d \leq 24$	result in LA
B	for motor shaft	$51 < L \leq 63$	$24 < \varnothing d \leq 35$	result in LB
C	for motor shaft	$63 < L \leq 83$	$24 < \varnothing d \leq 42$	result in LC

		1-stage	2-stage	3-stage
LA	[mm]	143	185	227
LB	[mm]	155	197	239
LC	[mm]	175	217	

Output

Standard

Optional

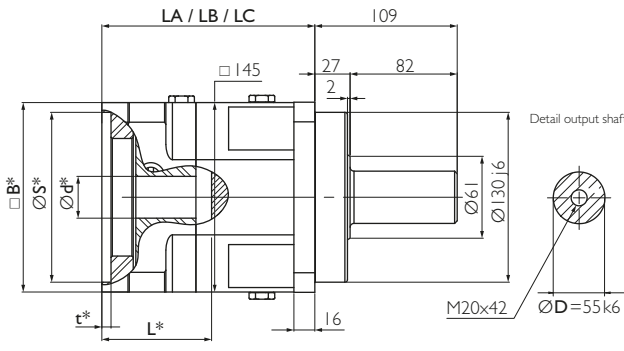
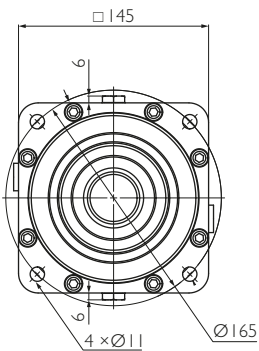

* depending on the motor. See pages 130 et seq.



Example SR 140 A2, 1-stage

Your ideal drive train

Function Package with gearbox, rack and pinion from Güdel

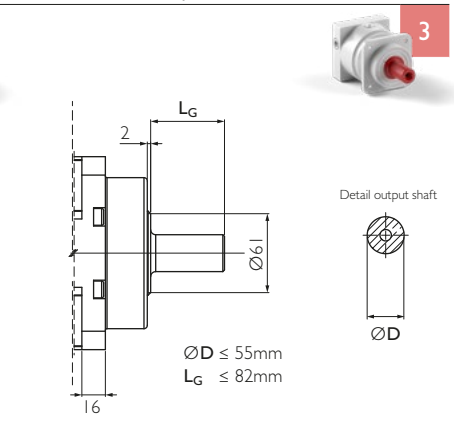
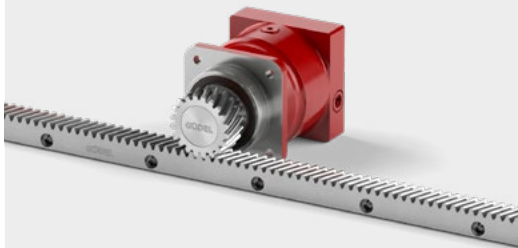

Option 3 on request. Adjustments can reduce capacity.

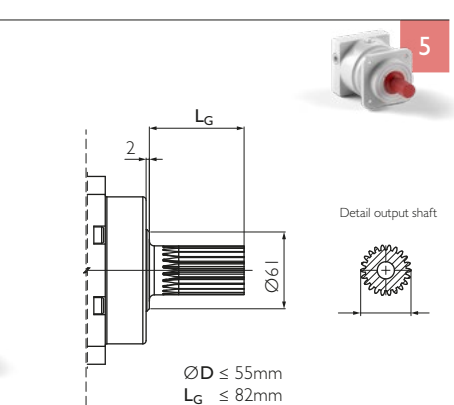
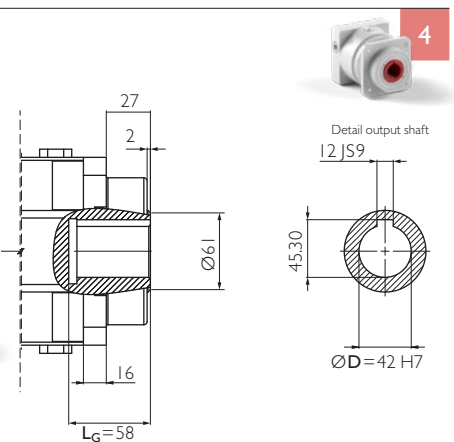

Option 5 on request. Adjustments can reduce capacity.

Material 16MnCr5 DIN 1.7131
 Teeth pressure angle $\alpha = 20^\circ$, helical teeth left, 19°31'42" hardened (58⁺⁴HRC), ground, crowned
 Quality 6f24 DIN 3962 / 63 / 67

Pinion



	m_n	P_t	z	A	b	D_k	D_0	D_v	L12	L13	x2	a	M	
Pinion 1	[-]	3	10.00	22	61.014	30	76.03	70.028	70.028	69.5	54.5	27.5	27	0.8
Pinion 2	[-]	4	13.33	20	77.441	40	92.88	84.883	84.883	79.0	59.0	32.0	27	1.6

m_n : Normal module, P_t : Transverse pitch [mm], z : Number of teeth, D_0 : Pitch circle diameter for calculation, D_v : Pitch circle diameter for design, M: Weight [kg]

Available ratios	i		1-stage		2-stage				
			4	12	16	20	28	40	
Nominal torque S5 ^{a)}	T _{2N}	[Nm]	500	500	500	500	500	500	
Acceleration torque S5 ^{b)}	T _{2B}	[Nm]	750	750	750	750	750	750	
Nominal input speed S5 ^{c)}	n _{1N}	[rpm]	1 900	2 400	2 600	2 600	2 600	2 600	
Maximum input speed S5	n _{1max}	[rpm]	3 600	3 600	3 600	3 600	3 600	3 600	
Emergency stop torque ^{d)}	T _{2not}	[Nm]	1 300	1 300	1 300	1 300	1 300	1 300	
Efficiency	η	[%]	96	93					
Lifetime	L _h	[h]	> 20 000						
Weight	M	[kg]	14	18					
Angular backlash	j _t	[arcmin]	Precision P I ≤ 1 / P 3 ≤ 3 / P 5 ≤ 5 / P 12 ≤ 12						
Torsionnal rigidity ^{e)}	C _{t2}	[Nm/arcmin]	106.2	85.0	95.7	102.1	95.7	95.7	
Noise ⁱ⁾	L _{pA}	[dB(A)]	≤ 71						
Max. permitted housing temperature ^{g)}	T	[°C]	90						
Protection class			IP 65						
Direction of rotation			Same way input / output						
Max. radial force on output shaft ^{f)}	F _{rmax}	[N]	Center of output shaft: 9 950 / End of output shaft: 6 700						
Max. axial force on output shaft ^{f)}	F _{amax}	[N]	10 300						
Color			Red, RAL 3003						
Inertia in kg·cm ² ^{h)}	Ø14	J ₁	[kg·cm ²]	7.12	6.86	6.63	5.29	4.15	3.48
	Ø19			7.12	6.86	6.63	5.29	4.15	3.48
	Ø24			8.13	7.87	7.64	6.30	5.16	4.49
	Ø32			10.33	10.07	9.84	8.50	7.36	6.69
	Ø35			13.16	12.90	12.67	11.33	10.19	9.52
	Ø38			18.35	18.09	17.86	16.52	15.38	14.71
	Ø42			17.95	17.69	17.46	16.12	14.98	14.31

- a) Nominal output torque when operating at n_{1N}.
b) 1 000 cycles per hour max.
c) Valid for an ambient temperature of 20°C and T_{2N}.
At higher ambient temperatures, please reduce speed.
d) Valid 1 000 times the gearbox life.

- e) Valid for an input Ø of 38 mm in 1-stage and 24 mm in 2- and 3-stage.
f) Values for 300 rpm.
g) For other temperatures, please contact us. Nominal output torque when operating at n_{1N}.
h) Depending on the motor output shaft Ø.
i) With n_{1N}=2500 rpm no load.

Rack



			Pinion 1			Pinion 2		
			Q6	Q7	Q9	Q6	Q7	Q9
Max acceleration force	F _{2B}	[N]	16 230	8 715	12 919	28 585	14 084	24 045
Max acceleration torque	T _{2B}	[Nm]	568	305	452	1 213	598	1 021
Precision			PI		PI2	PI		PI2
Feed force			High	Medium	Elevated	High	Medium	Elevated

Above values for rack and pinion take into consideration a number of load cycles:
1x10⁶ for the rack; 1x10⁷ for the pinion. Both in pulsating operation.

For proper sizing follow flowchart
calculate your ideal drive train
on pages 136 et seq.

More on the technical datasheets
your ideal drive train on pages
120 et seq.

Input

A	for motor shaft	$L \leq 51$	$14 \leq \varnothing d \leq 24$	result in LA
B	for motor shaft	$51 < L \leq 63$	$24 < \varnothing d \leq 35$	result in LB
C	for motor shaft	$63 < L \leq 83$	$24 < \varnothing d \leq 42$	result in LC

		1-stage	2-stage	3-stage
LA	[mm]	143	185	227
LB	[mm]	155	197	239
LC	[mm]	175	217	

Output

Standard Optional

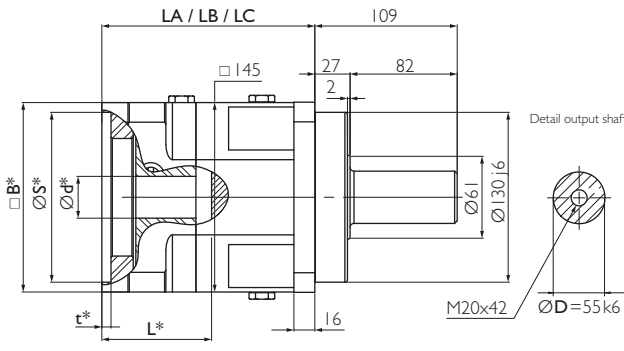
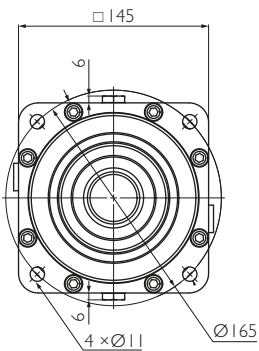

Example SR 140 A4, 1-stage

* depending on the motor. See pages 130 et seq.

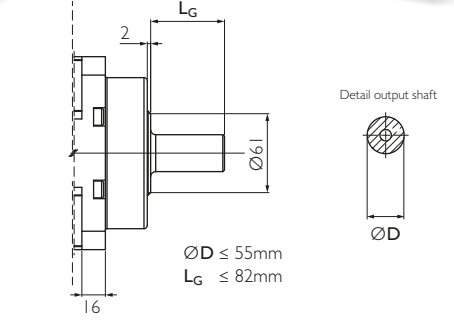
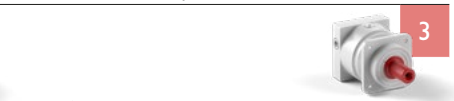
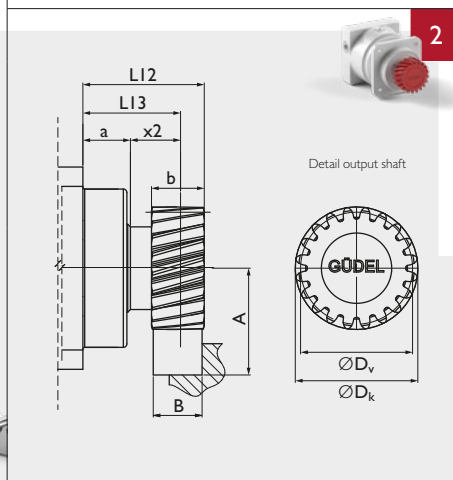
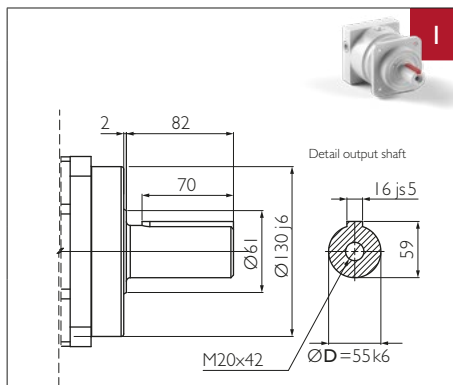

Option 3 on request. Adjustments can reduce capacity.

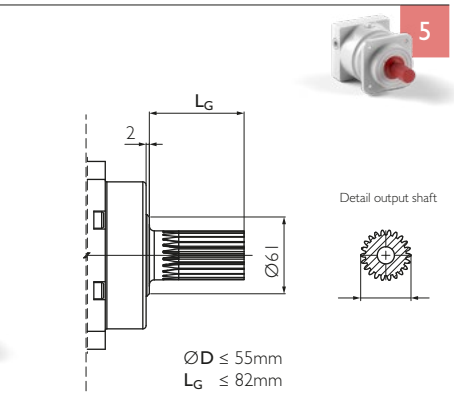
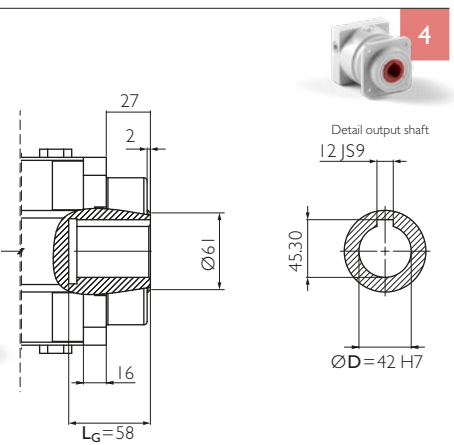

Option 5 on request. Adjustments can reduce capacity.

Material 16MnCr5 DIN 1.7131
 Teeth pressure angle $\alpha = 20^\circ$, helical teeth left, 19°31'42" hardened (58⁺⁴HRC), ground, crowned
 Quality 6f24 DIN 3962 / 63 / 67

Your ideal drive train

Function Package with gearbox, rack and pinion from Güdel

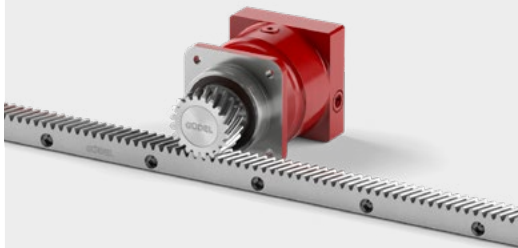

Pinion

	m_n	P_t	z	A	b	D_k	D_0	D_v	L12	L13	x2	a	M	
Pinion 1	[-]	3	10.00	22	61.014	30	76.03	70.028	70.028	69.5	54.5	27.5	27	0.8
Pinion 2	[-]	4	13.33	20	77.441	40	92.88	84.883	84.883	79.0	59.0	32.0	27	1.6

m_n : Normal module, P_t : Transverse pitch [mm], z : Number of teeth, D_0 : Pitch circle diameter for calculation, D_v : Pitch circle diameter for design, M: Weight [kg]

Available ratios *	i		3-stage										
			60	80	100	112	120	140	160	200	280	400	
Nominal torque S5 ^{a)}	T _{2N}	[Nm]	500	500	500	500	500	500	500	500	500	500	500
Acceleration torque S5 ^{b)}	T _{2B}	[Nm]	750	750	750	750	750	750	750	750	750	750	750
Nominal input speed S5 ^{c)}	n _{1N}	[rpm]	3 500	3 500	3 500	3 500	3 500	3 500	3 500	3 500	3 500	3 500	3 500
Maximum input speed S5	n _{1max}	[rpm]	4 000	4 000	4 000	4 000	4 000	4 000	4 000	4 000	4 000	4 000	4 000
Emergency stop torque ^{d)}	T _{2not}	[Nm]	1 300	1 300	1 300	1 300	1 300	1 300	1 300	1 300	1 300	1 300	1 300
Efficiency	η	[%]	90										
Lifetime	L _h	[h]	> 20 000										
Weight	M	[kg]	22										
Angular backlash	j _t	[arcmin]	Precision P I ≤ I / P 3 ≤ 3 / P 5 ≤ 5 / P 12 ≤ 12										
Torsionnal rigidity ^{e)}	C _{t2}	[Nm/arcmin]	92	92	84	86	86	92	86	92	86	86	86
Noise ⁱ⁾	L _{pA}	[dB(A)]	≤ 71										
Max. permitted housing temperature ^{g)}	T	[°C]	90										
Protection class			IP 65										
Direction of rotation			Same way input / output										
Max. radial force on output shaft ^{f)}	F _{rmax}	[N]	Center of output shaft: 9 950 / End of output shaft: 6 700										
Max. axial force on output shaft ^{f)}	F _{amax}	[N]	10 300										
Color			Red, RAL 3003										
Inertia in kg·cm ² ^{h)}	Ø14	J ₁	[kgcm ²]	5.28	5.27	3.44	4.14	3.47	4.11	3.47	3.46	3.45	3.44
	Ø19			5.28	5.27	3.44	4.14	3.47	4.11	3.47	3.46	3.45	3.44
	Ø24			6.29	6.28	4.45	5.15	4.48	5.12	4.48	4.47	4.46	4.45
	Ø32			8.49	8.48	6.65	7.35	6.68	7.32	6.68	6.67	6.66	6.65
	Ø35			11.32	11.31	9.48	10.18	9.51	10.15	9.51	9.50	9.49	9.48
	Ø38			16.51	16.50	14.67	15.37	14.70	15.34	14.70	14.69	14.68	14.67
	Ø42			16.11	16.10	14.27	14.97	14.30	14.94	14.30	14.29	14.28	14.27

* Other ratios available. 36, 64, 84, 180, 196, 300, 360, 500, 600, 700, 1 000 on request.

a) Nominal output torque when operating at n_{1N}.

b) Maximal 1 000 Zyklen pro Stunde

c) Valid for an ambient temperature of 20°C and T_{2N}.

At higher ambient temperatures, please reduce speed.

d) Valid 1000 times the gearbox life.

e) Valid for an input Ø of 38 mm in 1-stage and 24 mm in 2- and 3-stage.

f) Values for 300 rpm.

g) For other temperatures, please contact us. Nominal output torque when operating at n_{1N}.

h) Depending on the motor output shaft Ø.

i) With n_{1N}=2500 rpm no load.

Rack



			Pinion 1			Pinion 2		
			Q6	Q7	Q9	Q6	Q7	Q9
Max acceleration force	F _{2B}	[N]	16 230	8 715	12 919	28 585	14 084	24 045
Max acceleration torque	T _{2B}	[Nm]	568	305	452	1 213	598	1 021
Precision			PI		P12	PI		P12
Feed force			High	Medium	Elevated	High	Medium	Elevated

Above values for rack and pinion take into consideration a number of load cycles: 1x10⁶ for the rack; 1x10⁷ for the pinion. Both in pulsating operation.

For proper sizing follow flowchart
calculate your ideal drive train
on pages 136 et seq.

More on the technical datasheets
your ideal drive train on pages
120 et seq.

Input

A	for motor shaft	$L \leq 60$	$19 \leq \varnothing d \leq 32$	result in LA
B	for motor shaft	$60 < L \leq 85$	$32 < \varnothing d \leq 48$	result in LB
C	for motor shaft	$85 < L \leq 111$	$32 < \varnothing d \leq 48$	result in LC

		1-stage	2-stage	3-stage
LA	[mm]	168	220	273
LB	[mm]	193	246	298
LC	[mm]	219	272	

Output

0	Standard	3	Optional
----------	----------	----------	----------

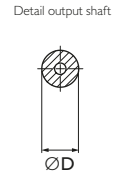
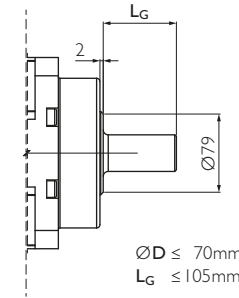

Option 3 on request. Adjustments can reduce capacity.

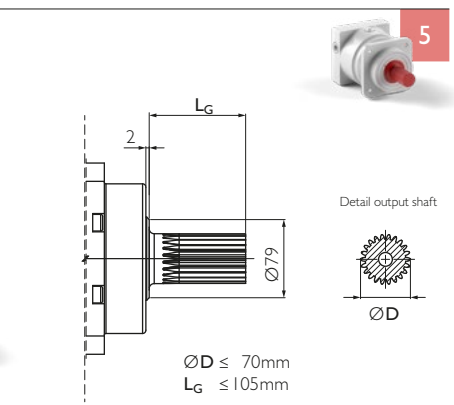
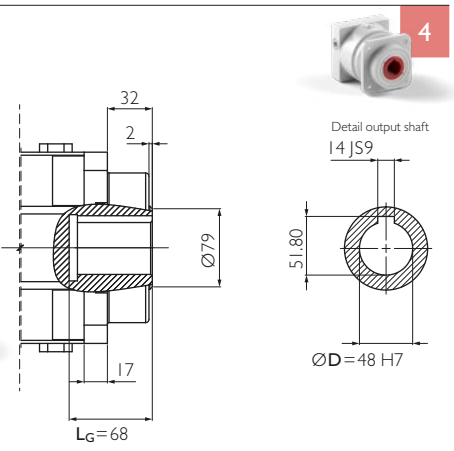

Option 5 on request. Adjustments can reduce capacity.

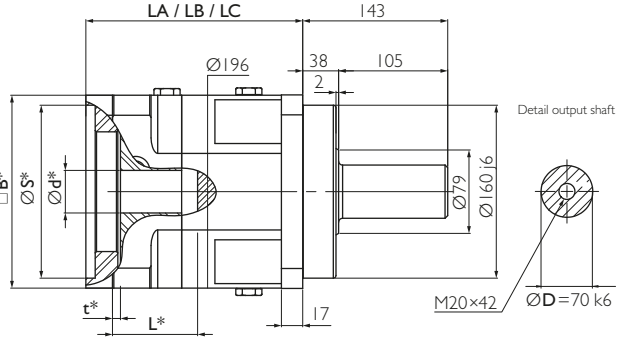
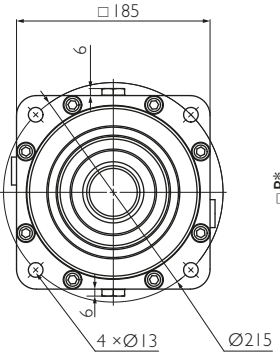

* depending on the motor. See pages 130 et seq.

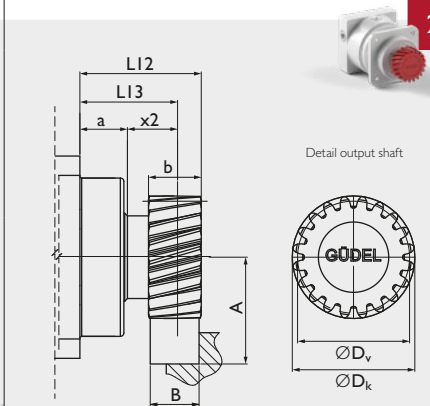
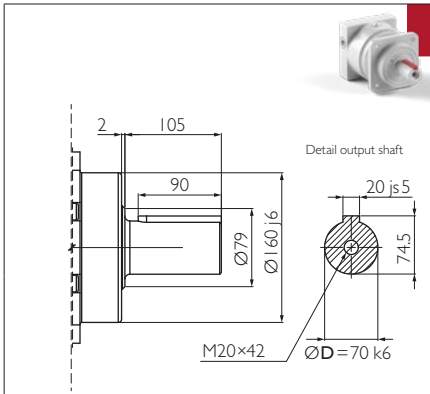

Example SR 180 A2, 1-stage

Your ideal drive train

Function Package with gearbox, rack and pinion from Güdel

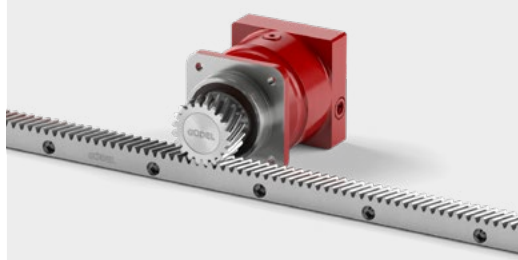

Pinion



	m_n	P_t	z	A	b	D_k	D_0	D_v	L12	L13	x2	a	M	
Pinion 1	[-]	4	13.33	20	77.441	40	92.88	84.883	84.883	89.5	69.5	31.5	38	1.5
Pinion 2	[-]	5	16.66	20	87.052	50	116.10	106.103	106.103	95.5	70.5	32.5	38	3.0

m_n : Normal module, P_t : Transverse pitch [mm], z : Number of teeth, D_0 : Pitch circle diameter for calculation, D_v : Pitch circle diameter for design, M: Weight [kg]

Available ratios	i		1-stage		2-stage				
			4	12	16	20	28	40	
Nominal torque S5 ^{a)}	T _{2N}	[Nm]	1 100	1 100	1 100	1 100	1 100	1 100	
Acceleration torque S5 ^{b)}	T _{2B}	[Nm]	1 500	1 500	1 500	1 500	1 500	1 500	
Nominal input speed S5 ^{c)}	n _{1N}	[rpm]	1 300	2 200	2 400	2 400	2 400	2 400	
Maximum input speed S5	n _{1max}	[rpm]	3 100	3 600	3 600	3 600	3 600	3 600	
Emergency stop torque ^{d)}	T _{2not}	[Nm]	2 780	2 780	2 780	2 780	2 780	2 780	
Efficiency	η	[%]	96	93					
Lifetime	L _h	[h]	> 20 000						
Weight	M	[kg]	32	39					
Angular backlash	j _t	[arcmin]	Precision P I ≤ 1 / P 3 ≤ 3 / P 5 ≤ 5 / P 12 ≤ 12						
Torsionnal rigidity ^{e)}	C _{t2}	[Nm/arcmin]	191.8	147.5	172.5	182.7	172.5	172.5	
Noise ⁱ⁾	L _{pA}	[dB(A)]	≤ 72						
Max. permitted housing temperature ^{g)}	T	[°C]	90						
Protection class			IP 65						
Direction of rotation			Same way input / output						
Max. radial force on output shaft ^{f)}	F _{rmax}	[N]	Center of output shaft: 18 000 / End of output shaft: 13 000						
Max. axial force on output shaft ^{f)}	F _{amax}	[N]	15 000						
Color			Red, RAL 3003						
Inertia in kg·cm ² ^{h)}	Ø19	J ₁	[kg·cm ²]	23.35	23.57	22.65	16.76	11.90	9.07
	Ø24			24.40	24.62	23.70	17.81	12.95	10.12
	Ø32			26.61	26.83	25.91	20.02	15.16	12.33
	Ø35			29.53	29.75	28.83	22.94	18.08	15.25
	Ø38			35.13	35.35	34.43	28.54	23.68	20.85
	Ø42			34.63	34.85	33.93	28.04	23.18	20.35
	Ø48			35.03	35.25	34.33	28.44	23.58	20.75

- a) Nominal output torque when operating at n_{1N}.
b) 1000 cycles per hour max.
c) Valid for an ambient temperature of 20°C and T_{2N}.
At higher ambient temperatures, please reduce speed.
d) Valid 1000 times the gearbox life.

- e) Valid for an input Ø of 48 mm in 1-stage and 38 mm in 2- and 3-stage.
f) Values for 300 rpm.
g) For other temperatures, please contact us. Nominal output torque when operating at n_{1N}.
h) Depending on the motor output shaft Ø.
i) With n_{1N}=2500 rpm no load.

Rack



			Pinion 1			Pinion 2		
			Q6	Q7	Q9	Q6	Q7	Q9
Max acceleration force	F _{2B}	[N]	28 585	14 084	24 045	44 505	23 785	40 048
Max acceleration torque	T _{2B}	[Nm]	1 213	598	1 021	2 361	1 262	2 125
Precision			PI		PI2	PI		PI2
Feed force			High	Medium	Elevated	High	Medium	Elevated

Above values for rack and pinion take into consideration a number of load cycles:
1x10⁶ for the rack; 1x10⁷ for the pinion. Both in pulsating operation.

For proper sizing follow flowchart
calculate your ideal drive train
on pages 136 et seq.

More on the technical datasheets
your ideal drive train on pages
120 et seq.

Input

A	for motor shaft	$L \leq 60$	$19 \leq \varnothing d \leq 32$	result in LA
B	for motor shaft	$60 < L \leq 85$	$32 < \varnothing d \leq 48$	result in LB
C	for motor shaft	$85 < L \leq 111$	$32 < \varnothing d \leq 48$	result in LC

Output

Standard Optional

		1-stage	2-stage	3-stage
LA	[mm]	168	220	273
LB	[mm]	193	246	298
LC	[mm]	219	272	

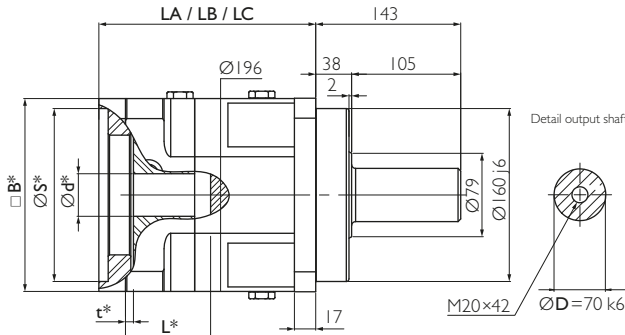
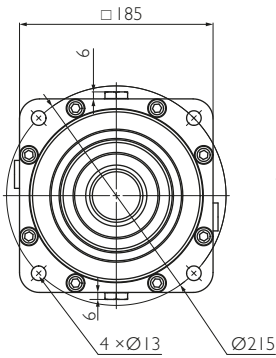

* depending on the motor. See pages 130 et seq.



Example SR 180 A5, 1-stage

Your ideal drive train

Function Package with gearbox, rack and pinion from Güdel

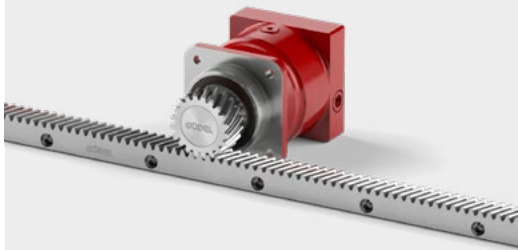

Pinion



	m_n	P_t	z	A	b	D_k	D_0	D_v	L12	L13	x2	a	M	
Pinion 1	[-]	4	13.33	20	77.441	40	92.88	84.883	84.883	89.5	69.5	31.5	38	1.5
Pinion 2	[-]	5	16.66	20	87.052	50	116.10	106.103	106.103	95.5	70.5	32.5	38	3.0

m_n : Normal module, P_t : Transverse pitch [mm], z : Number of teeth, D_0 : Pitch circle diameter for calculation, D_v : Pitch circle diameter for design, M: Weight [kg]

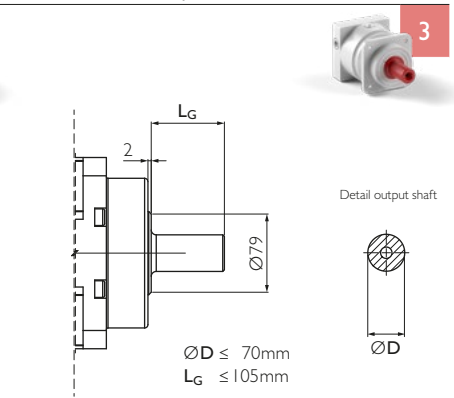

Option 3 on request. Adjustments can reduce capacity.

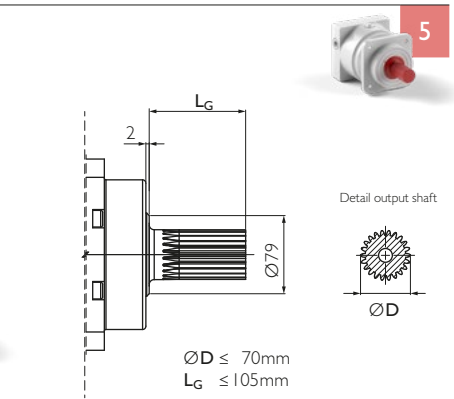
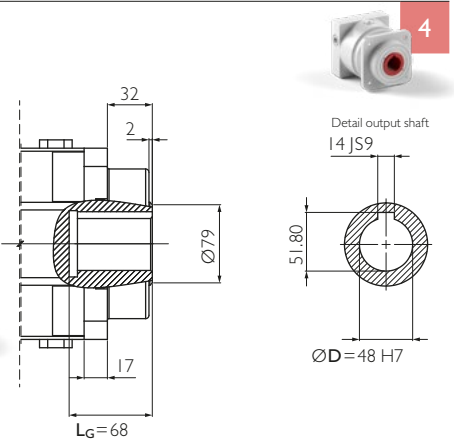

Option 5 on request. Adjustments can reduce capacity.

Material 16MnCr5 DIN 1.7131
 Teeth pressure angle $\alpha = 20^\circ$, helical teeth left, 19°31'42" hardened (58⁺⁴HRC), ground, crowned
 Quality 6f24 DIN 3962 / 63 / 67

Available ratios *	i		3-stage										
			60	80	100	112	120	140	160	200	280	400	
Nominal torque S5 ^{a)}	T _{2N}	[Nm]	1 100	1 100	1 100	1 100	1 100	1 100	1 100	1 100	1 100	1 100	
Acceleration torque S5 ^{b)}	T _{2B}	[Nm]	1 500	1 500	1 500	1 500	1 500	1 500	1 500	1 500	1 500	1 500	
Nominal input speed S5 ^{c)}	n _{1N}	[rpm]	3 000	3 000	3 000	3 000	3 000	3 000	3 000	3 000	3 000	3 000	
Maximum input speed S5	n _{1max}	[rpm]	3 600	3 600	3 600	3 600	3 600	3 600	3 600	3 600	3 600	3 600	
Emergency stop torque ^{d)}	T _{2not}	[Nm]	2 780	2 780	2 780	2 780	2 780	2 780	2 780	2 780	2 780	2 780	
Efficiency	η	[%]	90										
Lifetime	L _h	[h]	> 20 000										
Weight	M	[kg]	46										
Angular backlash	j _t	[arcmin]	Precision P 1 ≤ 1 / P 3 ≤ 3 / P 5 ≤ 5 / P 12 ≤ 12										
Torsionnal rigidity ^{e)}	C _{t2}	[Nm/arcmin]	173.4	173.4	173.1	164.1	164.1	173.4	164.1	140.0	164.1	164.1	
Noise ⁱ⁾	L _{pA}	[dB(A)]	≤ 72										
Max. permitted housing temperature ^{g)}	T	[°C]	90										
Protection class			IP 65										
Direction of rotation			Same way input / output										
Max. radial force on output shaft ^{f)}	F _{rmax}	[N]	Center of output shaft: 18 000 / End of output shaft: 13 000										
Max. axial force on output shaft ^{f)}	F _{amax}	[N]	15 000										
Color			Red, RAL 3003										
Inertia in kg·cm ² ^{h)}	Ø19	J ₁	[kg·cm ²]	16.77	16.73	8.93	11.88	9.07	11.76	9.06	9.00	8.96	8.93
	Ø24			17.82	17.78	9.98	12.93	10.12	12.81	10.11	10.05	10.01	9.98
	Ø32			20.03	19.99	12.19	15.14	12.33	15.02	12.32	12.26	12.22	12.19
	Ø35			22.95	22.91	15.11	18.06	15.25	17.94	15.24	15.18	15.14	15.11
	Ø38			28.55	28.51	20.71	23.66	20.85	23.54	20.84	20.78	20.74	20.71
	Ø42			28.05	28.01	20.21	23.16	20.35	23.04	20.34	20.28	20.24	20.21
	Ø48			28.45	28.41	20.61	23.56	20.75	23.44	20.74	20.68	20.64	20.61

* Other ratios available. 36, 64, 84, 180, 196, 300, 360, 500, 600, 700, 1000 on request.

a) Nominal output torque when operating at n_{1N}.

b) 1000 cycles per hour max.

c) Valid for an ambient temperature of 20°C and T_{2N}.

At higher ambient temperatures, please reduce speed.

d) Valid 1000 times the gearbox life.

e) Valid for an input Ø of 48 mm in 1-stage and 38 mm in 2- and 3-stage.

f) Values for 300 rpm.

g) For other temperatures, please contact us. Nominal output torque when operating at n_{1N}.

h) Depending on the motor output shaft Ø.

i) With n_{1N}=2500 rpm no load.

Rack



			Pinion 1			Pinion 2		
			Q6	Q7	Q9	Q6	Q7	Q9
Max acceleration force	F _{2B}	[N]	28 585	14 084	24 045	44 505	23 785	40 048
Max acceleration torque	T _{2B}	[Nm]	1 213	598	1 021	2 361	1 262	2 125
Precision			PI		P12	PI		P12
Feed force			High	Medium	Elevated	High	Medium	Elevated

Above values for rack and pinion take into consideration a number of load cycles: 1x10⁶ for the rack; 1x10⁷ for the pinion. Both in pulsating operation.

For proper sizing follow flowchart **calculate your ideal drive train** on pages 136 et seq.

More on the technical datasheets **your ideal drive train** on pages 120 et seq.

Input

A	for motor shaft	$L \leq 85$	$24 \leq \varnothing d \leq 48$	result in LA
B	for motor shaft	$85 < L \leq 115$	$48 < \varnothing d \leq 55$	result in LB

Output

0	Standard	3	Optional
----------	----------	----------	----------

		1-stage	2-stage	3-stage
LA	[mm]	229	300	371
LB	[mm]	259	330	

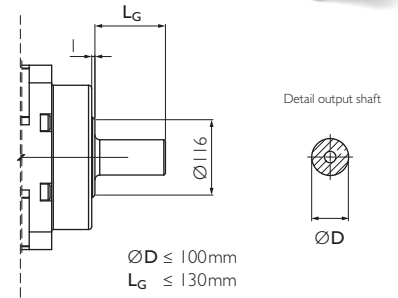

Option 3 on request. Adjustments can reduce capacity.

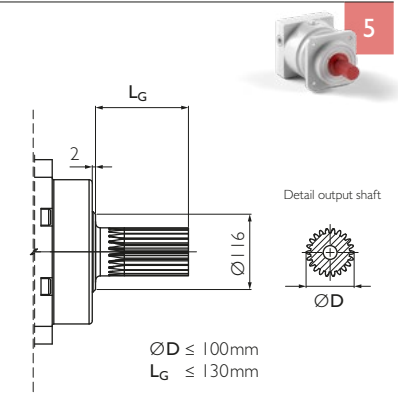
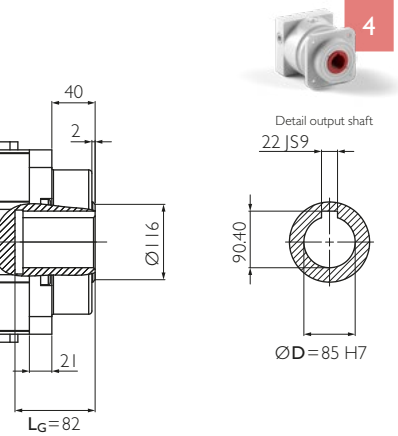

Option 5 on request. Adjustments can reduce capacity.

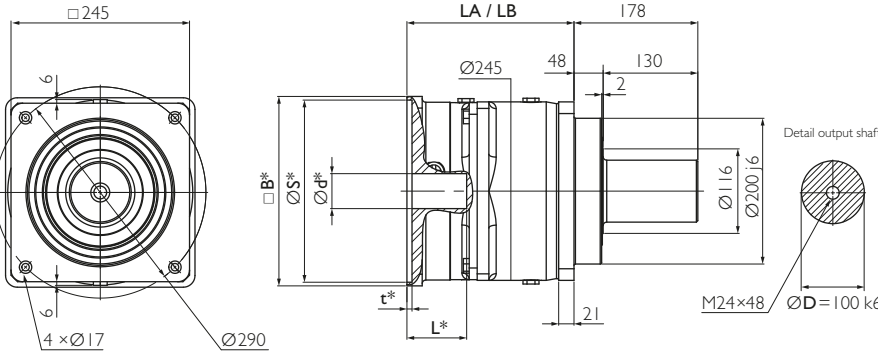

* depending on the motor. See pages 130 et seq.

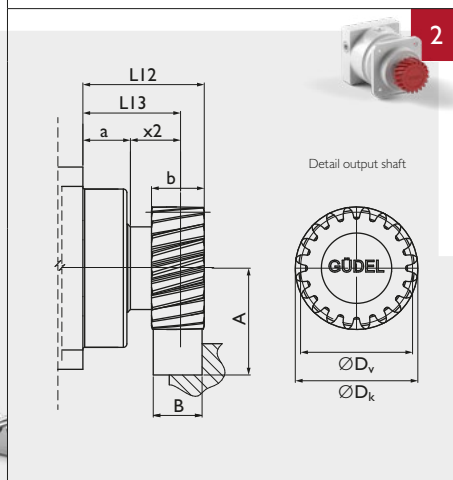
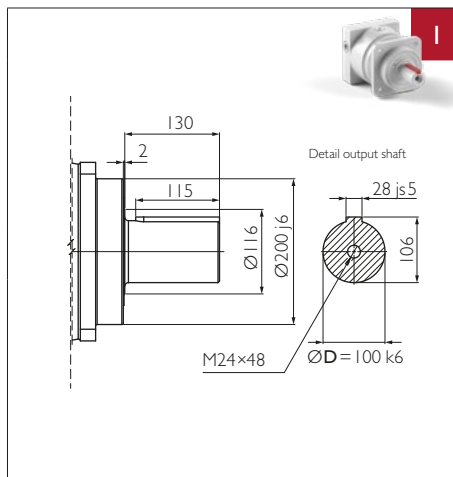

Example SR 240 B4, 1-stage

Your ideal drive train

Function Package with gearbox, rack and pinion from Güdel

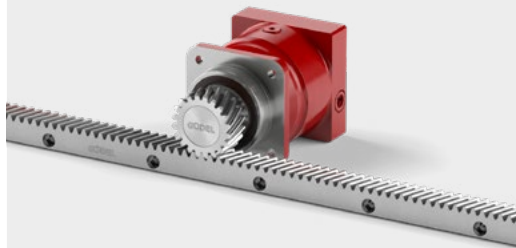

Pinion

	m_n	P_t	z	A	b	D_k	D_0	D_v	$L12$	$L13$	$\times 2$	a	M
Pinion 1	[-]	5	16.66	24	97.662	50	137.32	127.324	127.324	120.5	95.5	47.5	5.4
Pinion 2	[-]	6	20.00	20	106.662	60	139.32	127.324	127.324	119.0	89.0	41.0	5.6

m_n : Normal module, P_t : Transverse pitch [mm], z : Number of teeth, D_0 : Pitch circle diameter for calculation, D_v : Pitch circle diameter for design, M : Weight [kg]

Available ratios	i		1-stage		2-stage				
			4	12	16	20	28	40	
Nominal torque S5 ^{a)}	T _{2N}	[Nm]	3 600	3 600	3 600	3 600	3 600	3 600	
Acceleration torque S5 ^{b)}	T _{2B}	[Nm]	4 800	4 800	4 800	4 800	4 800	4 800	
Nominal input speed S5 ^{c)}	n _{1N}	[rpm]	900	1 500	1 700	1 700	1 700	1 700	
Maximum input speed S5	n _{1max}	[rpm]	2 000	3 100	3 100	3 100	3 100	3 100	
Emergency stop torque ^{d)}	T _{2not}	[Nm]	8 500	8 500	8 500	8 500	8 500	8 500	
Efficiency	η	[%]	96	93					
Lifetime	L _h	[h]	> 20 000						
Weight	M	[kg]	70	90					
Angular backlash	j _t	[arcmin]	Precision P I ≤ 1 / P 3 ≤ 3 / P 5 ≤ 5 / P 12 ≤ 12						
Torsionnal rigidity ^{e)}	C _{t2}	[Nm/arcmin]	718.8	593.5	611.0	628.5	611.0	611.0	
Noise ⁱ⁾	L _{pA}	[dB(A)]	≤ 73						
Max. permitted housing temperature ^{g)}	T	[°C]	90						
Protection class			IP 65						
Direction of rotation			Same way input / output						
Max. radial force on output shaft ^{f)}	F _{rmax}	[N]	Center of output shaft: 37 500 / End of output shaft: 25 000						
Max. axial force on output shaft ^{f)}	F _{amax}	[N]	34 000						
Color			Red, RAL 3003						
Inertia in kg·cm ² ^{h)}	Ø24	J ₁	[kg·cm ²]	83.3	79.1	74.9	73.3	34.0	22.9
	Ø32			85.5	81.3	77.1	75.5	36.2	25.1
	Ø35			90.8	86.6	82.4	80.8	41.5	30.4
	Ø38			94.2	90.0	85.8	84.2	44.9	33.8
	Ø42			93.7	89.5	85.3	83.7	44.4	33.3
	Ø48			93.9	89.7	85.5	83.9	44.6	33.5
	Ø55			116.5	112.3	108.1	106.5	67.2	56.1

- a) Nominal output torque when operating at n_{1N}.
b) 1000 cycles per hour max.
c) Valid for an ambient temperature of 20°C and T_{2N}.
At higher ambient temperatures, please reduce speed.
d) Valid 1000 times the gearbox life.

- e) Valid for an input Ø of 55 mm in 1-stage and 48 mm in 2- and 3-stage.
f) Values for 300 rpm.
g) For other temperatures, please contact us. Nominal output torque when operating at n_{1N}.
h) Depending on the motor output shaft Ø.
i) With n_{1N}=1800 rpm no load.

Rack



			Pinion 1			Pinion 2		
			Q6	Q7	Q9	Q6	Q7	Q9
Max acceleration force	F _{2B}	[N]	44 786	29 748	39 992	63 300	-	59 005
Max acceleration torque	T _{2B}	[Nm]	2 851	1 894	2 546	4 030	-	3 756
Precision			PI		PI2	PI		PI2
Feed force			High	Medium	Elevated	High	Medium	Elevated

Above values for rack and pinion take into consideration a number of load cycles:
1x10⁶ for the rack; 1x10⁷ for the pinion. Both in pulsating operation.

For proper sizing follow flowchart
calculate your ideal drive train
on pages 136 et seq.

More on the technical datasheets
your ideal drive train on pages
120 et seq.

Input

A	for motor shaft	$L \leq 85$	$24 \leq \varnothing d \leq 48$	result in LA
B	for motor shaft	$85 < L \leq 115$	$48 < \varnothing d \leq 55$	result in LB

Output

0	Standard	3	Optional
----------	----------	----------	----------

		1-stage	2-stage	3-stage
LA	[mm]	229	300	371
LB	[mm]	259	330	

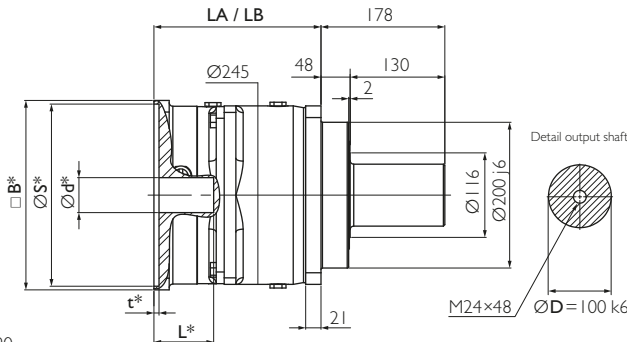
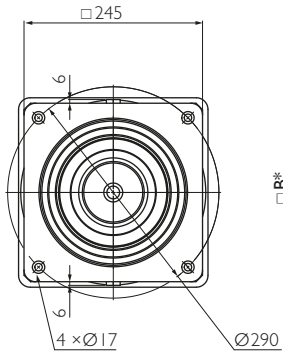

* depending on the motor. See pages 130 et seq.

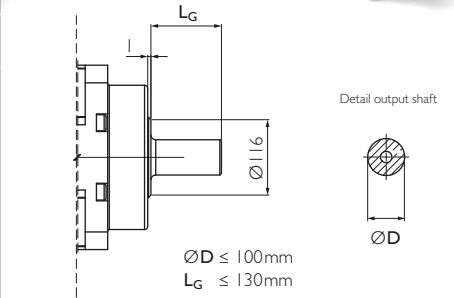

Option 3 on request. Adjustments can reduce capacity.

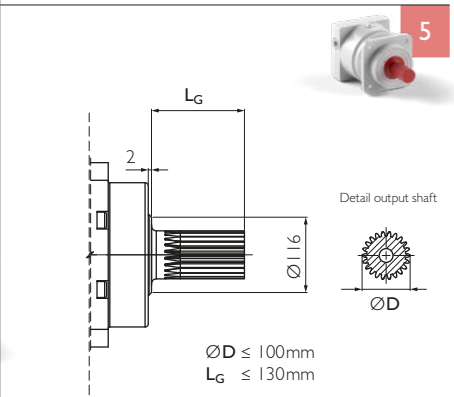
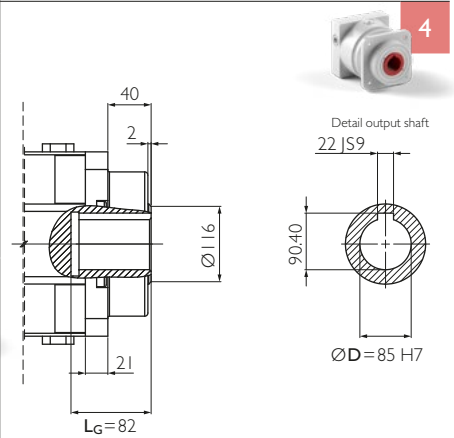

Option 5 on request. Adjustments can reduce capacity.

Material 16MnCr5 DIN 1.7131
 Teeth pressure angle $\alpha = 20^\circ$, helical teeth left, $19^\circ 31' 42''$ hardened (58⁺⁴ HRC), ground, crowned
 Quality 6f24 DIN 3962 / 63 / 67



Example SR 240 B2, 1-stage

Your ideal drive train

Function Package with gearbox, rack and pinion from Güdel

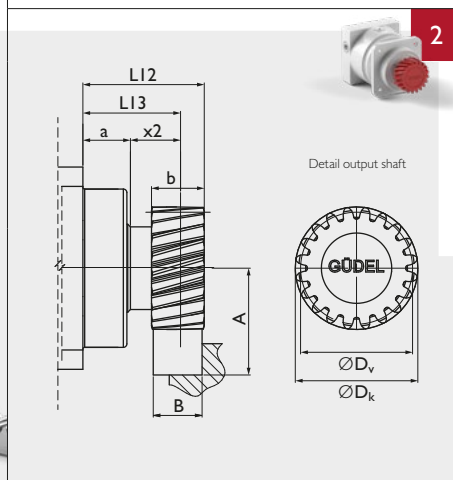
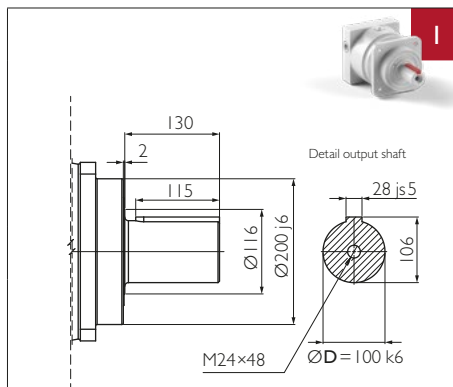
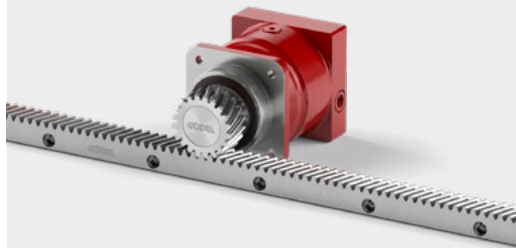

Pinion

	m_n	P_t	z	A	b	D_k	D_0	D_v	L12	L13	x2	a	M	
Pinion 1	[-]	5	16.66	24	97.662	50	137.32	127.324	127.324	120.5	95.5	47.5	48	5.4
Pinion 2	[-]	6	20.00	20	106.662	60	139.32	127.324	127.324	119.0	89.0	41.0	48	5.6

m_n : Normal module, P_t : Transverse pitch [mm], z : Number of teeth, D_0 : Pitch circle diameter for calculation, D_v : Pitch circle diameter for design, M: Weight [kg]

Available ratios *	i		3-stage										
			60	80	100	112	120	140	160	200	280	400	
Nominal torque S5 ^{a)}	T _{2N}	[Nm]	3 600	3 600	3 600	3 600	3 600	3 600	3 600	3 600	3 600	3 600	
Acceleration torque S5 ^{b)}	T _{2B}	[Nm]	4 800	4 800	4 800	4 800	4 800	4 800	4 800	4 800	4 800	4 800	
Nominal input speed S5 ^{c)}	n _{1N}	[rpm]	2 100	2 100	2 100	2 100	2 100	2 100	2 100	2 100	2 100	2 100	
Maximum input speed S5	n _{1max}	[rpm]	3 100	3 100	3 100	3 100	3 100	3 100	3 100	3 100	3 100	3 100	
Emergency stop torque ^{d)}	T _{2not}	[Nm]	8 500	8 500	8 500	8 500	8 500	8 500	8 500	8 500	8 500	8 500	
Efficiency	η	[%]	90										
Lifetime	L _h	[h]	> 20 000										
Weight	M	[kg]	110										
Angular backlash	j _t	[arcmin]	Precision P 1 ≤ 1 / P 3 ≤ 3 / P 5 ≤ 5 / P 12 ≤ 12										
Torsionnal rigidity ^{e)}	C _{t2}	[Nm/arcmin]	532.4	532.4	593.5	550.0	550.0	564.5	550.0	564.5	550.0	561.5	
Noise ⁱ⁾	L _{pA}	[dB(A)]	≤ 73										
Max. permitted housing temperature ^{g)}	T	[°C]	90										
Protection class			IP 65										
Direction of rotation			Same way input / output										
Max. radial force on output shaft ^{f)}	F _{rmax}	[N]	Center of output shaft: 37 500 / End of output shaft: 25 000										
Max. axial force on output shaft ^{f)}	F _{amax}	[N]	34 000										
Color			Red, RAL 3003										
Inertia in kg.cm ² ^{h)}	Ø24	J ₁	[kgcm ²]	78.0	74.2	22.3	33.9	23.4	33.9	22.8	22.8	22.4	22.3
	Ø32			80.2	76.4	24.5	36.1	25.6	36.1	25.0	25.0	24.6	24.5
	Ø35			85.5	81.7	29.8	41.4	30.9	41.4	30.3	30.3	29.9	29.8
	Ø38			88.9	85.1	33.2	44.8	34.3	44.8	33.7	33.7	33.3	33.2
	Ø42			88.4	84.6	32.7	44.3	33.8	44.3	33.2	33.2	32.8	32.7
	Ø48			88.6	84.8	32.9	44.5	34.0	44.5	33.4	33.4	33.0	32.9
	Ø55			111.2	107.4	55.5	67.1	56.6	67.1	56.0	56.0	55.6	55.5

* Other ratios available. 36, 64, 84, 180, 196, 300, 360, 500, 600, 700, 1 000 on request.

a) Nominal output torque when operating at n_{1N}.

b) 1 000 cycles per hour max.

c) Valid for an ambient temperature of 20°C and T_{2N}.

At higher ambient temperatures, please reduce speed.

d) Valid 1000 times the gearbox life.

e) Valid for an input Ø of 55 mm in 1-stage and 48 mm in 2- and 3-stage.

f) Values for 300 rpm.

g) For other temperatures, please contact us. Nominal output torque when operating at n_{1N}.

h) Depending on the motor output shaft Ø.

i) With n_{1N}=1800 rpm no load.

Rack



			Pinion 1			Pinion 2		
			Q6	Q7	Q9	Q6	Q7	Q9
Max acceleration force	F _{2B}	[N]	44 786	29 748	39 992	63 300	-	59 005
Max acceleration torque	T _{2B}	[Nm]	2 851	1 894	2 546	4 030	-	3 756
Precision			PI		P12	PI		P12
Feed force			High	Medium	Elevated	High	Medium	Elevated

Above values for rack and pinion take into consideration a number of load cycles: 1x10⁶ for the rack; 1x10⁷ for the pinion. Both in pulsating operation.

For proper sizing follow flowchart **calculate your ideal drive train** on pages 136 et seq.

More on the technical datasheets **your ideal drive train** on pages 120 et seq.

Input

A	for motor shaft	$L \leq 45$	$6 \leq \varnothing d \leq 19$	result in LA
B	for motor shaft	$45 < L \leq 55$	$19 < \varnothing d \leq 24$	result in LB

		1-stage	2-stage	3-stage
LA	[mm]	106.5	128.5	150.5
LB	[mm]	116	138	160

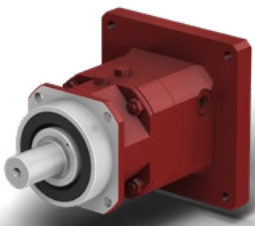
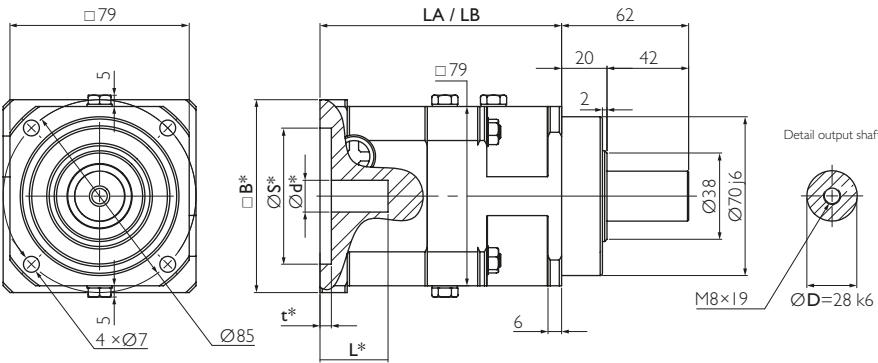

Example PR 080 B0, 1-stage

* depending on the motor. See pages 130 et seq.

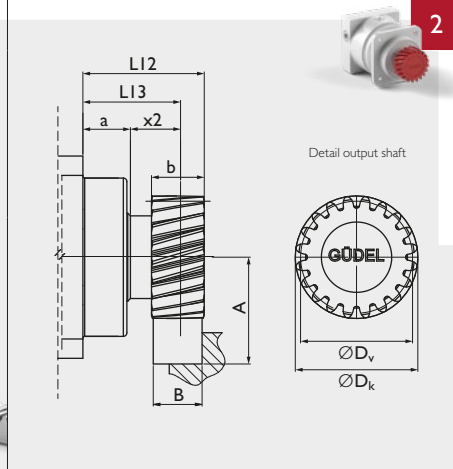
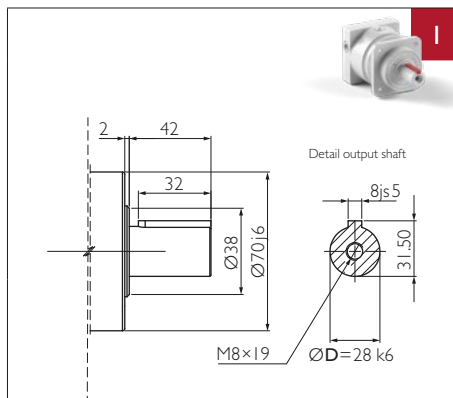

Output

0	
3	
4	
5	

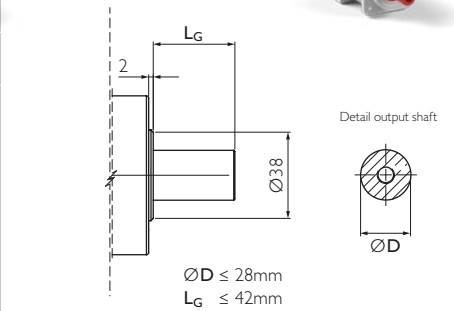

Option 3 on request. Adjustments can reduce capacity.

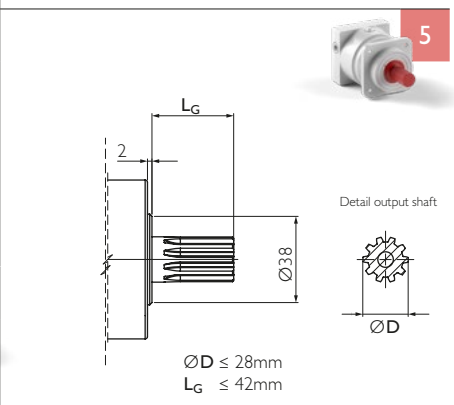
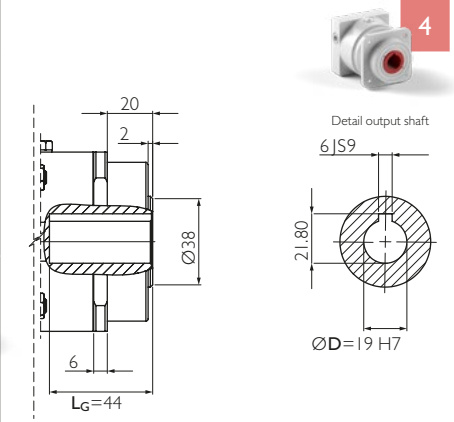

Option 5 on request. Adjustments can reduce capacity.

Material 16MnCr5 DIN 1.7131
 Teeth pressure angle $\alpha = 20^\circ$, helical teeth left, $19^\circ 31' 42''$ hardened (58^{+4} HRC), ground, crowned
 Quality 6f24 DIN 3962 / 63 / 67

Your ideal drive train

Function Package with gearbox, rack and pinion from Güdel

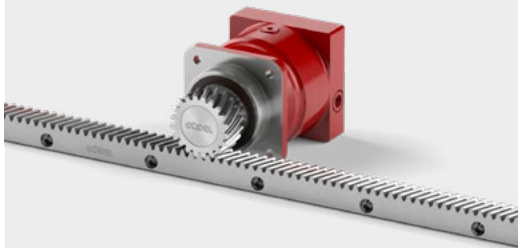

Pinion

Pinion for PR on request



Available ratios	i		1-stage		2-stage				
			3	9	12	15	21	30	
Nominal torque S5 ^{a)}	T _{2N}	[Nm]	120	120	120	120	120	120	
Acceleration torque S5 ^{b)}	T _{2B}	[Nm]	160	160	160	160	160	160	
Nominal input speed S5 ^{c)}	n _{1N}	[rpm]	2 300	2 300	2 600	2 800	2 800	2 800	
Maximum input speed S5	n _{1max}	[rpm]	4 000	4 000	4 800	4 800	4 800	4 800	
Emergency stop torque ^{d)}	T _{2not}	[Nm]	210	200	200	200	200	200	
Efficiency	η	[%]	94	91					
Lifetime	L _h	[h]	> 20 000						
Weight	M	[kg]	4	5					
Angular backlash	j _t	[arcmin]	Precision P I ≤ 1 / P 3 ≤ 3 / P 5 ≤ 5 / P 12 ≤ 12						
Torsionnal rigidity ^{e)}	C _{t2}	[Nm/arcmin]	12.2	11.6	12.2	11.6	11.6	11.6	
Noise ⁱ⁾	L _{pA}	[dB(A)]	≤ 70						
Max. permitted housing temperature ^{g)}	T	[°C]	90						
Protection class			IP 65						
Direction of rotation			Same way input / output						
Max. radial force on output shaft ^{f)}	F _{rmax}	[N]	Center of output shaft: 4 200 / End of output shaft: 3 285						
Max. axial force on output shaft ^{f)}	F _{amax}	[N]	3 600						
Color			Red, RAL 3003						
Inertia in kg·cm ² ^{h)}	Ø11	J _I	[kgcm ²]	0.62	0.62	0.46	0.40	0.34	0.31
	Ø14			1.18	1.17	1.01	0.95	0.90	0.86
	Ø19			1.19	1.19	1.03	0.96	0.91	0.88
	Ø24			2.01	2.00	1.84	1.78	1.73	1.69

- a) Nominal output torque when operating at n_{1N}.
b) 1000 cycles per hour max.
c) Valid for an ambient temperature of 20°C and T_{2N}.
At higher ambient temperatures, please reduce speed.
d) Valid 1000 times the gearbox life.

- e) Valid for an input Ø of 19mm in 1-stage and 14mm in 2- and 3-stage.
f) Values for 300 rpm.
g) For other temperatures, please contact us. Nominal output torque when operating at n_{1N}.
h) Depending on the motor output shaft Ø.
i) With n_{1N}=2500 rpm no load.

Rack

Rack for PR on request

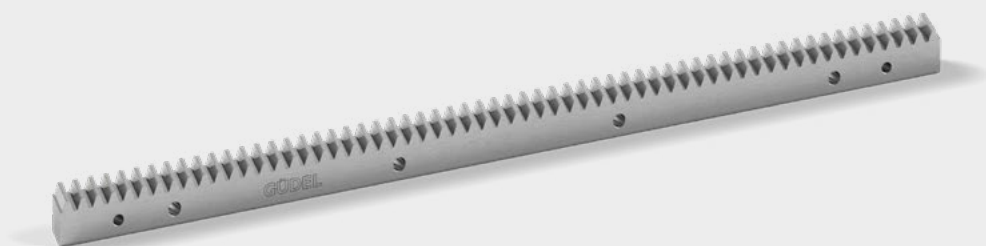

Input

A	for motor shaft	$L \leq 45$	$6 \leq \varnothing d \leq 19$	result in LA
B	for motor shaft	$45 < L \leq 55$	$19 < \varnothing d \leq 24$	result in LB

Output

Standard

Optional

		1-stage	2-stage	3-stage
LA	[mm]	106.5	128.5	150.5
LB	[mm]	116	138	160

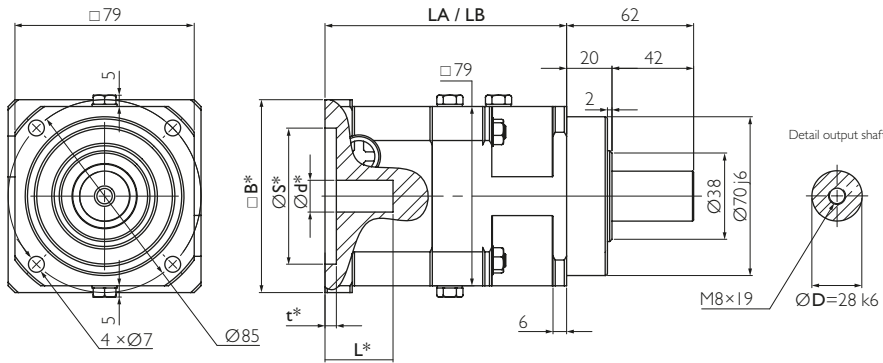

* depending on the motor. See pages 130 et seq.



Example PR 080 A0, 3-stage

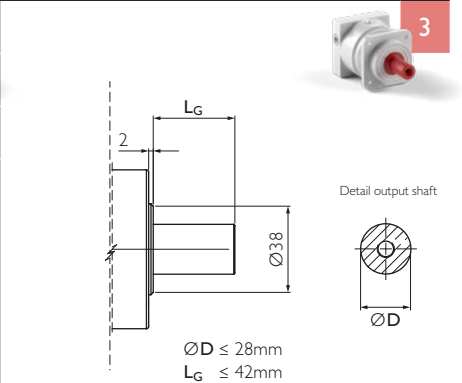

Option 3 on request. Adjustments can reduce capacity.

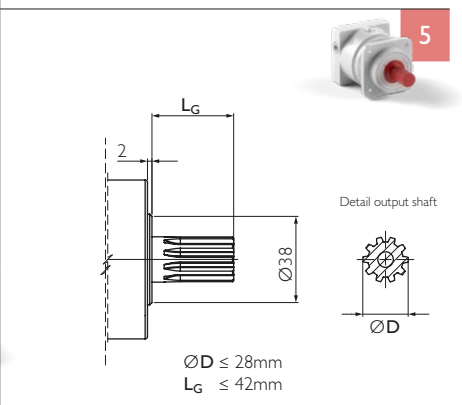
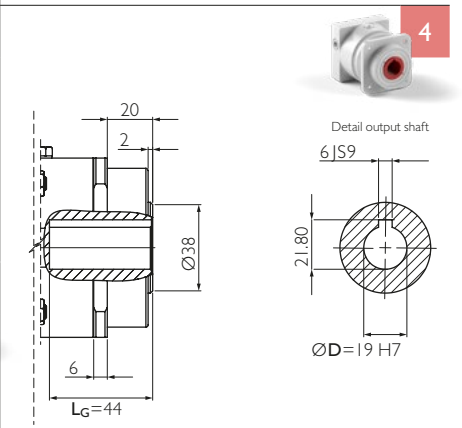

Option 5 on request. Adjustments can reduce capacity.

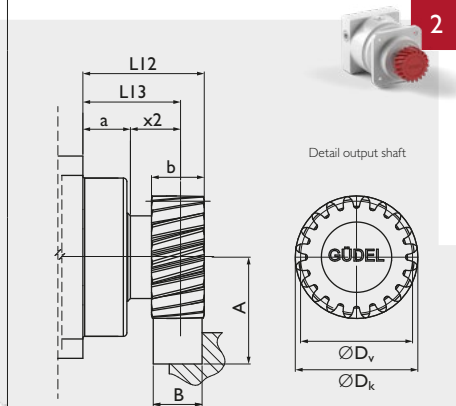
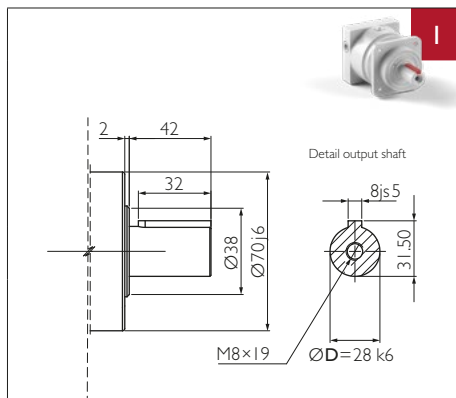

Your ideal drive train

Function Package with gearbox, rack and pinion from Güdel

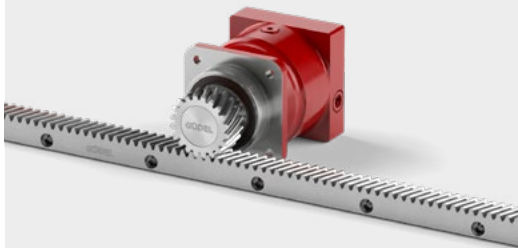

Pinion

Pinion for PR on request



Material 16MnCr5 DIN 1.7131
 Teeth pressure angle $\alpha = 20^\circ$, helical teeth left, 19°31'42"
 hardened (58⁺⁴HRC), ground, crowned
 Quality 6f24 DIN 3962 / 63 / 67

Available ratios *	i		3-stage										
			36	45	60	75	90	105	120	150	210	300	
Nominal torque S5 ^{a)}	T _{2N}	[Nm]	120	120	120	120	120	120	120	120	120	120	120
Acceleration torque S5 ^{b)}	T _{2B}	[Nm]	160	160	160	160	160	160	160	160	160	160	160
Nominal input speed S5 ^{c)}	n _{1N}	[rpm]	3 000	3 600	3 600	3 600	3 600	3 600	3 600	3 600	3 600	3 600	3 600
Maximum input speed S5	n _{1max}	[rpm]	4 800	4 800	4 800	4 800	4 800	4 800	4 800	4 800	4 800	4 800	4 800
Emergency stop torque ^{d)}	T _{2not}	[Nm]	200	200	200	200	200	200	200	200	200	200	200
Efficiency	η	[%]	88										
Lifetime	L _h	[h]	> 20 000										
Weight	M	[kg]	6										
Angular backlash	j _t	[arcmin]	Precision P 1 ≤ 1 / P 3 ≤ 3 / P 5 ≤ 5 / P 12 ≤ 12										
Torsionnal rigidity ^{e)}	C _{t2}	[Nm/arcmin]	11.6	11.6	11.8	11.8	11.1	11.8	11.6	11.8	11.9	11.1	
Noise ⁱ⁾	L _{pA}	[dB(A)]	≤ 71										
Max. permitted housing temperature ^{g)}	T	[°C]	90										
Protection class			IP 65										
Direction of rotation			Same way input / output										
Max. radial force on output shaft ^{f)}	F _{rmax}	[N]	Center of output shaft: 4 200 / End of output shaft: 3 285										
Max. axial force on output shaft ^{f)}	F _{amax}	[N]	3 600										
Color			Red, RAL 3003										
Inertia in kg·cm ² h)	Ø11	J ₁	[kgcm ²]	0.46	0.40	0.46	0.40	0.31	0.34	0.31	0.31	0.31	0.31
	Ø14			1.01	0.95	1.01	0.95	0.86	0.90	0.86	0.86	0.86	0.86
	Ø19			1.03	0.96	1.03	0.96	0.88	0.91	0.88	0.88	0.88	0.88
	Ø24			1.84	1.78	1.84	1.78	1.69	1.73	1.69	1.69	1.69	1.69

* Other ratios available. 27, 48, 63, 84, 147 on request.

- a) Nominal output torque when operating at n_{1N}.
 b) 1 000 cycles per hour max.
 c) Valid for an ambient temperature of 20°C and T_{2N}.
 At higher ambient temperatures, please reduce speed.

d) Valid 1 000 times the gearbox life.

e) Valid for an input Ø of 19 mm in 1-stage and 14 mm in 2- and 3-stage.

f) Values for 300 rpm.

g) For other temperatures, please contact us. Nominal output torque when operating at n_{1N}.

h) Depending on the motor output shaft Ø.

i) With n_{1N}=2500 rpm no load.

Rack

Rack for PR on request

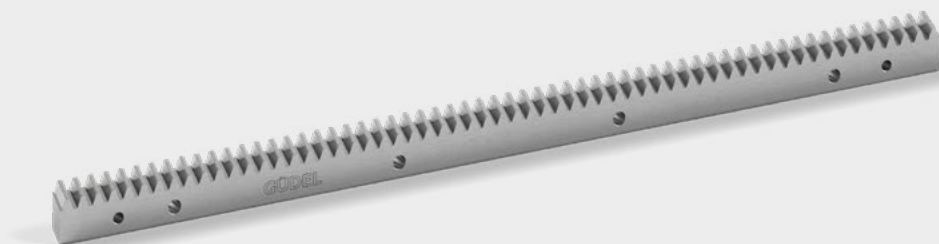

Input

A	for motor shaft	$L \leq 50$	$9 \leq \varnothing d \leq 24$	result in LA
B	for motor shaft	$51 < L \leq 64$	$24 < \varnothing d \leq 35$	result in LB

		1-stage	2-stage	3-stage
LA	[mm]	126	164	202
LB	[mm]	140	178	216

Output

0	Optional	3
----------	----------	----------

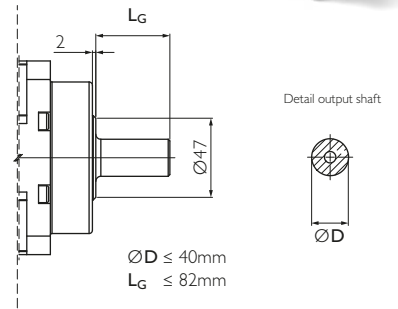

Option 3 on request. Adjustments can reduce capacity.

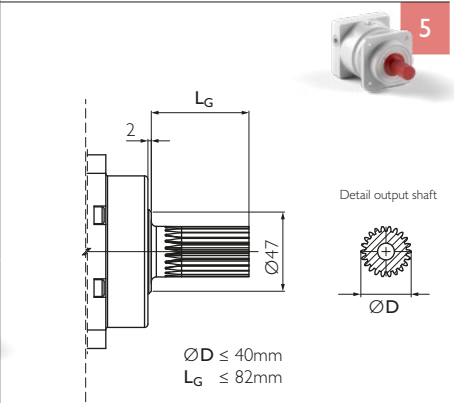
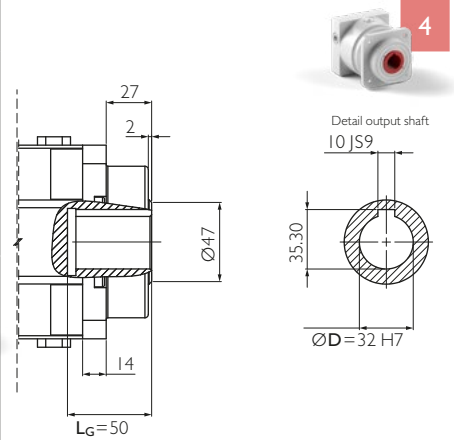

Option 5 on request. Adjustments can reduce capacity.

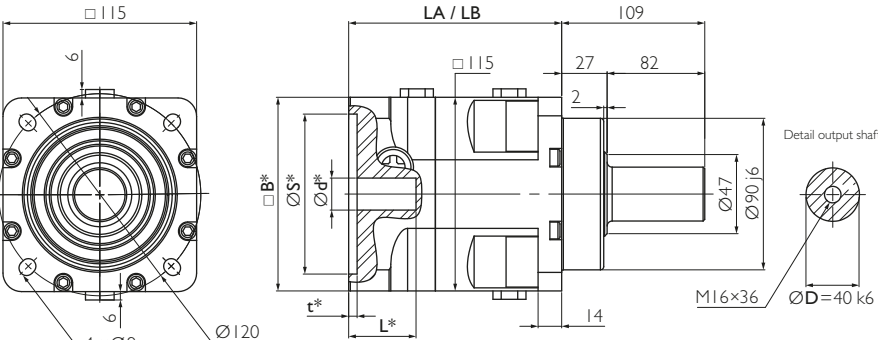

* depending on the motor. See pages 130 et seq.

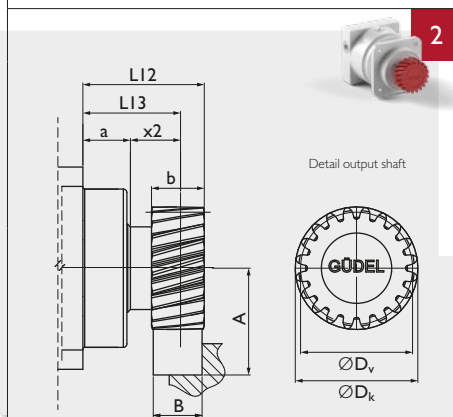
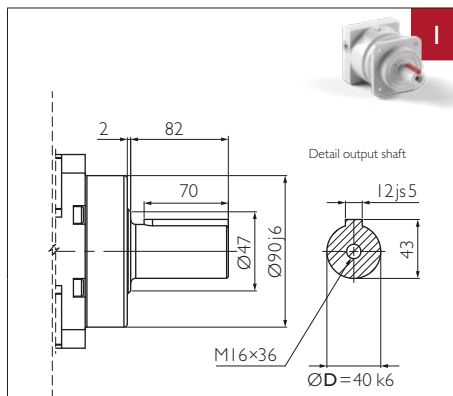

Example PR 100 A5, 1-stage

Your ideal drive train

Function Package with gearbox, rack and pinion from Güdel

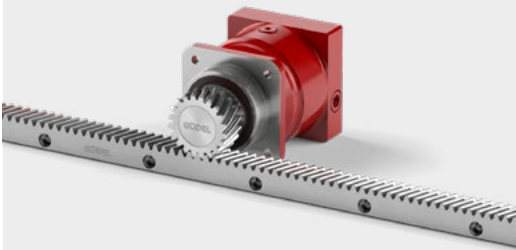

Pinion

Pinion for PR on request



Material 16MnCr5 DIN 1.7131
 Teeth pressure angle $\alpha = 20^\circ$, helical teeth left, $19^\circ 31' 42''$ hardened (58⁺⁴HRC), ground, crowned
 Quality 6f24 DIN 3962 / 63 / 67

Available ratios	i		1-stage		2-stage				
			3	9	12	15	21	30	
Nominal torque S5 ^{a)}	T _{2N}	[Nm]	348	350	350	350	350	350	
Acceleration torque S5 ^{b)}	T _{2B}	[Nm]	556	500	500	500	500	500	
Nominal input speed S5 ^{c)}	n _{1N}	[rpm]	2 000	2 000	2 300	2 500	2 500	2 500	
Maximum input speed S5	n _{1max}	[rpm]	3 200	3 200	3 600	3 600	3 600	3 600	
Emergency stop torque ^{d)}	T _{2not}	[Nm]	870	785	785	785	785	785	
Efficiency	η	[%]	94	91					
Lifetime	L _h	[h]	> 20 000						
Weight	M	[kg]	8	10					
Angular backlash	j _t	[arcmin]	Precision P I ≤ 1 / P 3 ≤ 3 / P 5 ≤ 5 / P 12 ≤ 12						
Torsionnal rigidity ^{e)}	C _{t2}	[Nm/arcmin]	37,0	35,2	35,2	35,2	35,2	35,2	
Noise ⁱ⁾	L _{pA}	[dB(A)]	≤ 71						
Max. permitted housing temperature ^{g)}	T	[°C]	90						
Protection class			IP 65						
Direction of rotation			Same way input / output						
Max. radial force on output shaft ^{f)}	F _{rmax}	[N]	Center of output shaft: 6 600 / End of output shaft: 4 300						
Max. axial force on output shaft ^{f)}	F _{amax}	[N]	6 000						
Color			Red, RAL 3003						
Inertia in kg.cm ² h)	Ø14	J ₁	[kgcm ²]	4.08	3.97	2.76	2.33	1.86	1.61
	Ø19			4.08	3.97	2.76	2.33	1.86	1.61
	Ø24			4.09	3.98	2.77	2.34	1.87	1.62
	Ø32			7.29	7.18	5.97	5.54	5.07	4.82
	Ø35			9.9	9.81	8.60	8.17	7.70	7.45

a) Nominal output torque when operating at n_{1N}.

b) 1000 cycles per hour max.

c) Valid for an ambient temperature of 20°C and T_{2N}.
At higher ambient temperatures, please reduce speed.

d) Valid 1000 times the gearbox life.

e) Valid for an input Ø of 24 mm in 1-stage and 19 mm in 2- and 3-stage.

f) Values for 300 rpm.

g) For other temperatures, please contact us. Nominal output torque when operating at n_{1N}.

h) Depending on the motor output shaft Ø.

i) With n_{1N}=2500 rpm no load.

Rack

Rack for PR on request

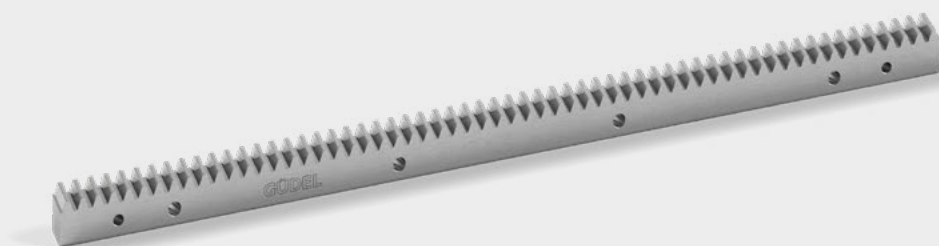

Input

A	for motor shaft	$L \leq 50$	$9 \leq \varnothing d \leq 24$	result in LA
B	for motor shaft	$51 < L \leq 64$	$24 < \varnothing d \leq 35$	result in LB

		1-stage	2-stage	3-stage
LA	[mm]	126	164	202
LB	[mm]	140	178	216

Output

0	Optional	3
----------	----------	----------

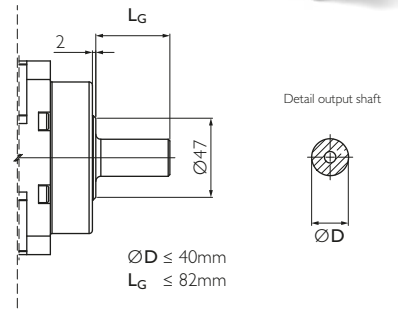

Option 3 on request. Adjustments can reduce capacity.

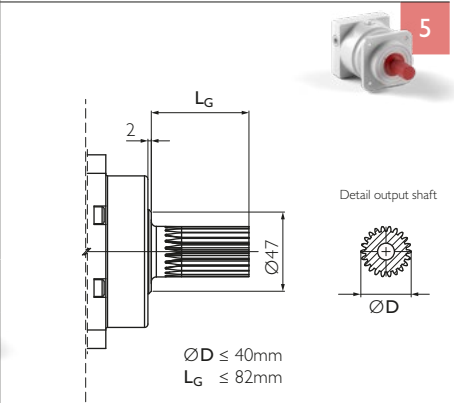
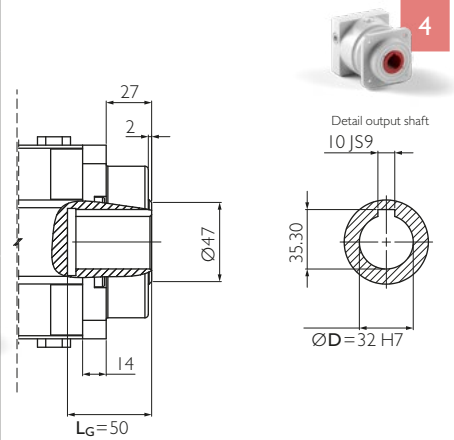

Option 5 on request. Adjustments can reduce capacity.

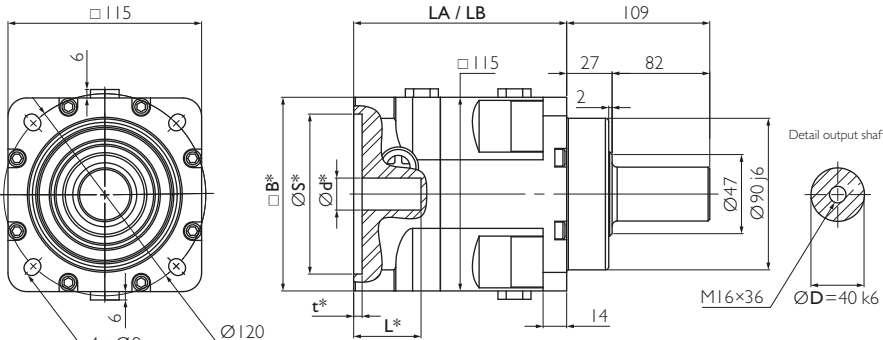

* depending on the motor. See pages 130 et seq.

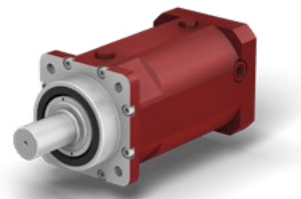
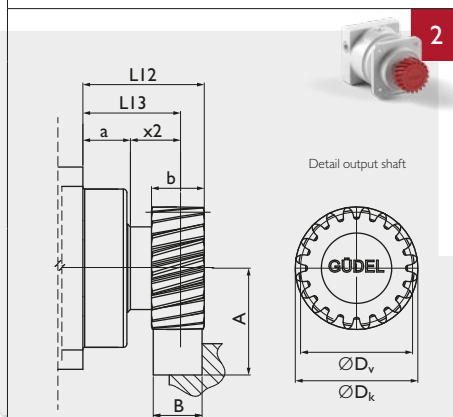
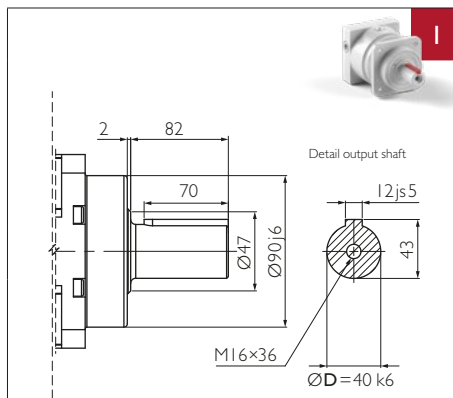

Example PR 100 A0, 3-stage

Your ideal drive train

Function Package with gearbox, rack and pinion from Güdel

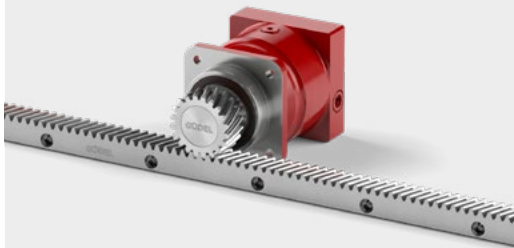

Pinion

Pinion for PR on request



Material 16MnCr5 DIN 1.7131
Teeth pressure angle $\alpha = 20^\circ$, helical teeth left, $19^\circ 31' 42''$ hardened (58⁺⁴ HRC), ground, crowned
Quality 6f24 DIN 3962 / 63 / 67

Available ratios *	i		3-stage										
			36	45	60	75	90	105	120	150	210	300	
Nominal torque S5 ^{a)}	T _{2N}	[Nm]	350	350	350	350	350	350	350	350	350	350	350
Acceleration torque S5 ^{b)}	T _{2B}	[Nm]	500	500	500	500	500	500	500	500	500	500	500
Nominal input speed S5 ^{c)}	n _{1N}	[rpm]	2 700	3 300	3 300	3 300	3 300	3 300	3 300	3 300	3 300	3 300	3 300
Maximum input speed S5	n _{1max}	[rpm]	4 000	4 000	4 000	4 000	4 000	4 000	4 000	4 000	4 000	4 000	4 000
Emergency stop torque ^{d)}	T _{2not}	[Nm]	785	785	785	785	785	785	785	785	785	785	785
Efficiency	η	[%]	88										
Lifetime	L _h	[h]	> 20 000										
Weight	M	[kg]	12										
Angular backlash	j _t	[arcmin]	Precision P 1 ≤ 1 / P 3 ≤ 3 / P 5 ≤ 5 / P 12 ≤ 12										
Torsionnal rigidity ^{e)}	C _{t2}	[Nm/arcmin]	33.5	33.5	42.2	42.2	33.5	42.2	40.4	42.2	43.1	40.4	40.4
Noise ⁱ⁾	L _{pA}	[dB(A)]	≤ 71										
Max. permitted housing temperature ^{g)}	T	[°C]	90										
Protection class			IP 65										
Direction of rotation			Same way input / output										
Max. radial force on output shaft ^{f)}	F _{rmax}	[N]	Center of output shaft: 6 600 / End of output shaft: 4 300										
Max. axial force on output shaft ^{f)}	F _{amax}	[N]	6 000										
Color			Red, RAL 3003										
Inertia in kg·cm ² h)	Ø14	J ₁	[kgcm ²]	2.76	2.28	2.23	2.21	1.61	1.82	1.60	1.59	1.59	1.59
	Ø19			2.76	2.28	2.23	2.21	1.61	1.82	1.60	1.59	1.59	1.59
	Ø24			2.77	2.29	2.24	2.22	1.62	1.83	1.61	1.60	1.60	1.60
	Ø32			5.97	5.49	5.44	5.42	4.82	5.03	4.81	4.80	4.80	4.80
	Ø35			8.60	8.12	8.07	8.05	7.45	7.66	7.44	7.43	7.43	7.43

* Other ratios available. 27, 48, 63, 84, 147 on request.

- a) Nominal output torque when operating at n_{1N}.
b) 1 000 cycles per hour max.
c) Valid for an ambient temperature of 20°C and T_{2N}.
At higher ambient temperatures, please reduce speed.

- d) Valid 1 000 times the gearbox life.
e) Valid for an input Ø of 24 mm in 1-stage and 19 mm in 2- and 3-stage.
f) Values for 300 rpm.
g) For other temperatures, please contact us. Nominal output torque when operating at n_{1N}.
h) Depending on the motor output shaft Ø.
i) With n_{1N}=2500 rpm no load.

Rack

Rack for PR on request

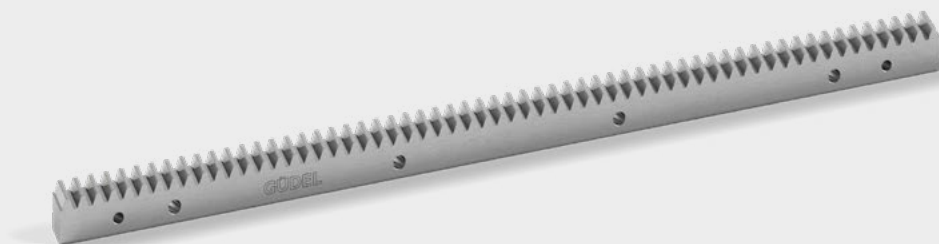

Input

A	for motor shaft	$L \leq 51$	$14 \leq \varnothing d \leq 24$	result in LA
B	for motor shaft	$51 < L \leq 63$	$24 < \varnothing d \leq 35$	result in LB
C	for motor shaft	$63 < L \leq 83$	$24 < \varnothing d \leq 42$	result in LC

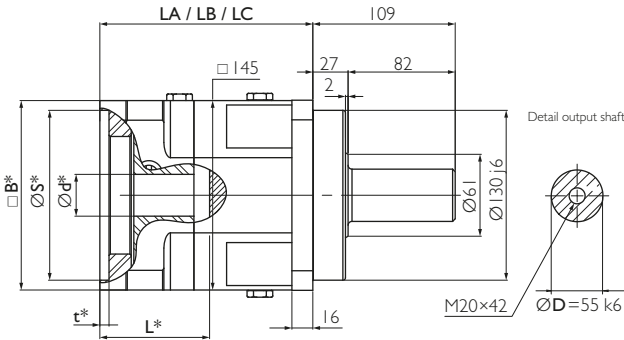
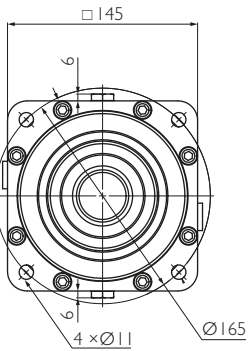

* depending on the motor. See pages 130 et seq.

Output

Standard

Optional

		1-stage	2-stage	3-stage
LA	[mm]	143	185	227
LB	[mm]	155	197	239
LC	[mm]	175	217	

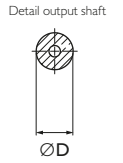
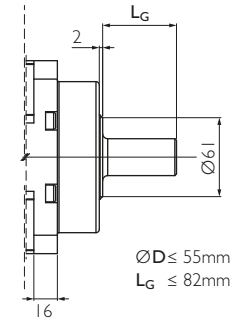

$\varnothing D \leq 55\text{mm}$
 $L_G \leq 82\text{mm}$

Option 3 on request. Adjustments can reduce capacity.

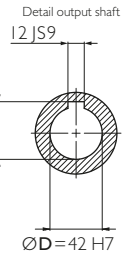
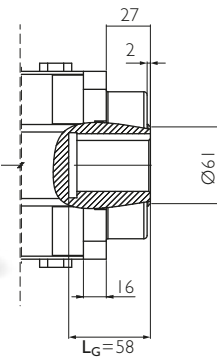

$\varnothing D = 42\text{ H7}$

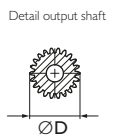
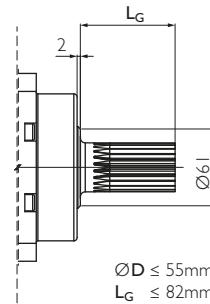
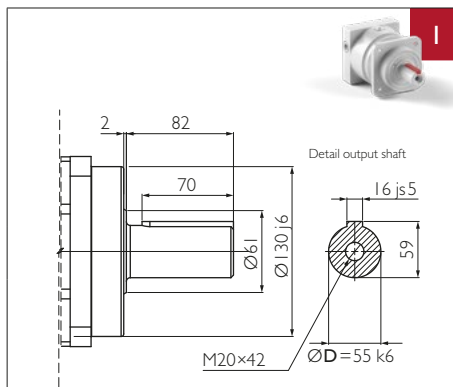

$\varnothing D \leq 55\text{mm}$
 $L_G \leq 82\text{mm}$

Option 5 on request. Adjustments can reduce capacity.

Material 16MnCr5 DIN 1.7131
Teeth pressure angle $\alpha = 20^\circ$, helical teeth left, $19^\circ 31' 42''$ hardened (58⁺⁴ HRC), ground, crowned
Quality 6f24 DIN 3962 / 63 / 67



Example PR 140 AI, 1-stage

Your ideal drive train

Function Package with gearbox, rack and pinion from Güdel

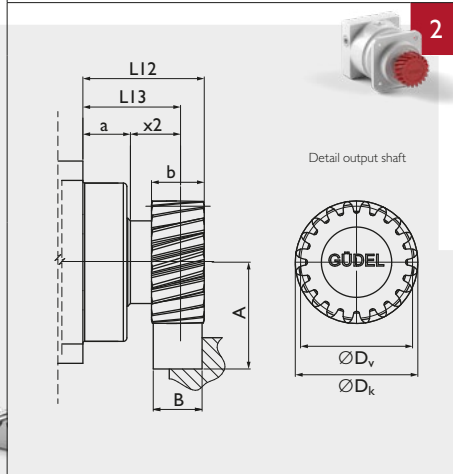
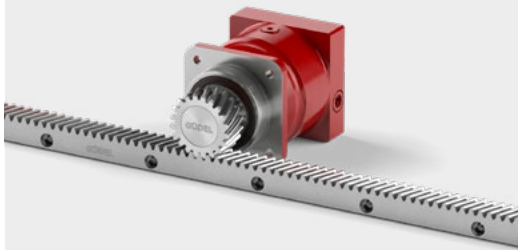

Pinion

Pinion for PR on request



Available ratios	i		1-stage		2-stage				
			3	9	12	15	21	30	
Nominal torque SS ^{a)}	T _{2N}	[Nm]	700	700	700	700	700	700	
Acceleration torque SS ^{b)}	T _{2B}	[Nm]	900	900	900	900	900	900	
Nominal input speed SS ^{c)}	n _{1N}	[rpm]	1 500	1 600	2 500	2 500	2 500	2 500	
Maximum input speed SS	n _{1max}	[rpm]	2 500	2 600	3 200	3 200	3 200	3 200	
Emergency stop torque ^{d)}	T _{2not}	[Nm]	1 250	1 250	1 250	1 250	1 250	1 250	
Efficiency	η	[%]	94	91					
Lifetime	L _h	[h]	> 20 000						
Weight	M	[kg]	14	18					
Angular backlash	j _t	[arcmin]	Precision P I ≤ 1 / P 3 ≤ 3 / P 5 ≤ 5 / P 12 ≤ 12						
Torsionnal rigidity ^{e)}	C _{t2}	[Nm/arcmin]	103.3	93.1	93.1	93.1	93.1	93.1	
Noise ⁱ⁾	L _{pA}	[dB(A)]	≤ 71						
Max. permitted housing temperature ^{g)}	T	[°C]	90						
Protection class			IP 65						
Direction of rotation			Same way input / output						
Max. radial force on output shaft ^{f)}	F _{rmax}	[N]	Center of output shaft: 9 950 / End of output shaft: 6 700						
Max. axial force on output shaft ^{f)}	F _{amax}	[N]	10 300						
Color			Red, RAL 3003						
Inertia in kg.cm ² ^{h)}	Ø14	J ₁	[kgcm ²]	10.98	10.53	6.86	5.44	4.23	3.52
	Ø19			10.98	10.53	6.86	5.44	4.23	3.52
	Ø24			11.99	11.54	7.87	6.45	5.24	4.53
	Ø32			14.19	13.74	10.07	8.65	7.44	6.73
	Ø35			17.02	16.57	12.90	11.48	10.27	9.56
	Ø38			22.21	21.76	18.09	16.67	15.46	14.75
	Ø42			21.81	21.36	17.69	16.27	15.06	14.35

- a) Nominal output torque when operating at n_{1N}.
b) 1 000 cycles per hour max.
c) Valid for an ambient temperature of 20°C and T_{2N}.
At higher ambient temperatures, please reduce speed.
d) Valid 1 000 times the gearbox life.

- e) Valid for an input Ø of 38 mm in 1-stage and 24 mm in 2- and 3-stage.
f) Values for 300 rpm.
g) For other temperatures, please contact us. Nominal output torque when operating at n_{1N}.
h) Depending on the motor output shaft Ø.
i) With n_{1N}=2500 rpm no load.

Rack

Rack for PR on request

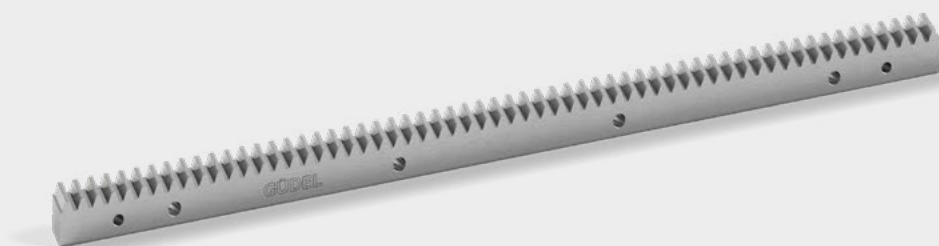

Input

A	for motor shaft	$L \leq 51$	$14 \leq \varnothing d \leq 24$	result in LA
B	for motor shaft	$51 < L \leq 63$	$24 < \varnothing d \leq 35$	result in LB
C	for motor shaft	$63 < L \leq 83$	$24 < \varnothing d \leq 42$	result in LC

		1-stage	2-stage	3-stage
LA	[mm]	143	185	227
LB	[mm]	155	197	239
LC	[mm]	175	217	

Output

Standard Optional

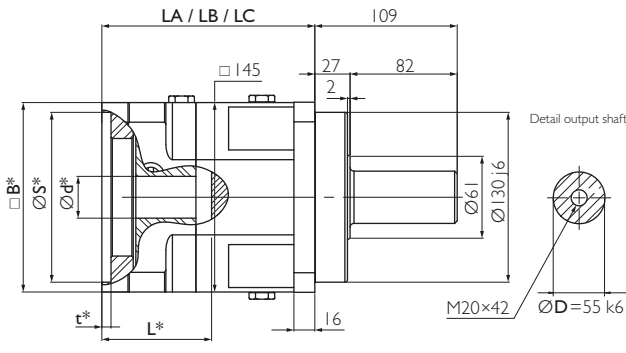
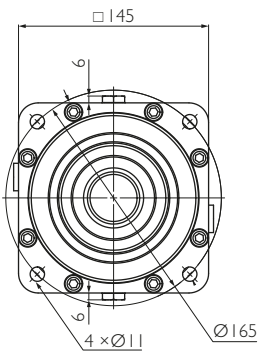

* depending on the motor. See pages 130 et seq.

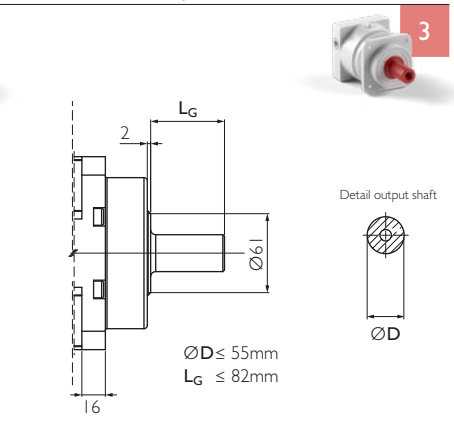

Option 3 on request. Adjustments can reduce capacity.

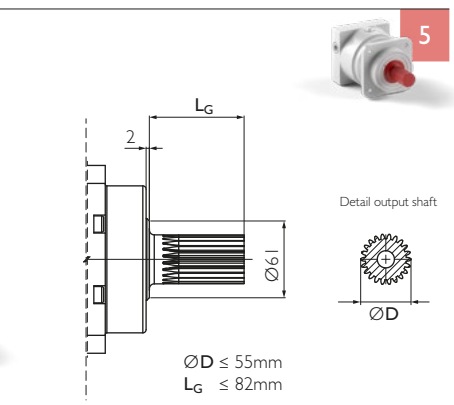
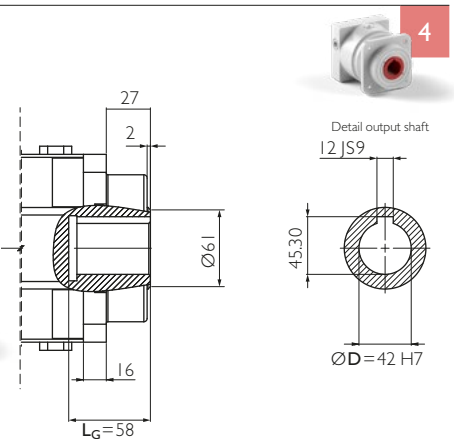

Option 5 on request. Adjustments can reduce capacity.

Material 16MnCr5 DIN 1.7131
 Teeth pressure angle $\alpha = 20^\circ$, helical teeth left, $19^\circ 31' 42''$ hardened (58⁺⁴ HRC), ground, crowned
 Quality 6f24 DIN 3962 / 63 / 67



Example PR 140 A5, 1-stage

Your ideal drive train

Function Package with gearbox, rack and pinion from Güdel

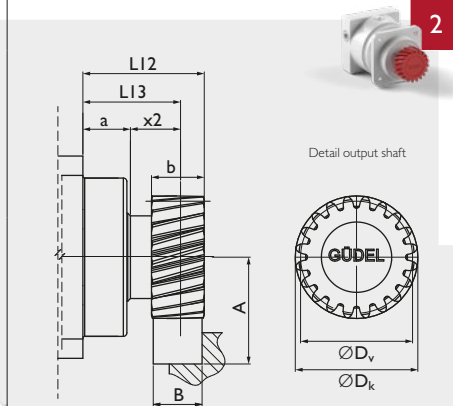
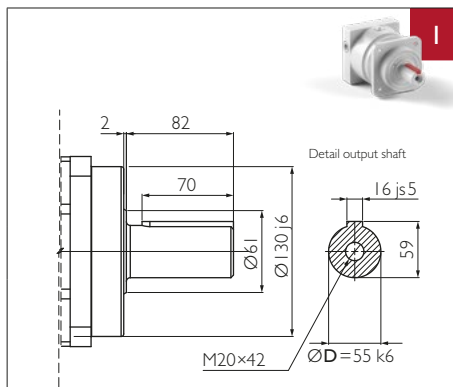
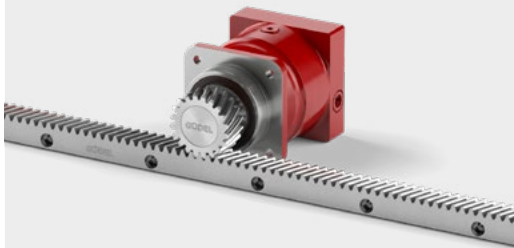

Pinion

Pinion for PR on request



Available ratios *	i		3-stage										
			36	45	60	75	90	105	120	150	210	300	
Nominal torque S5 ^{a)}	T _{2N}	[Nm]	700	700	700	700	700	700	700	700	700	700	700
Acceleration torque S5 ^{b)}	T _{2B}	[Nm]	900	900	900	900	900	900	900	900	900	900	900
Nominal input speed S5 ^{c)}	n _{1N}	[rpm]	2 200	2 900	2 900	3 500	3 500	3 500	3 500	3 500	3 500	3 500	3 500
Maximum input speed S5	n _{1max}	[rpm]	4 000	4 000	4 000	4 000	4 200	4 200	4 200	4 200	4 200	4 200	4 200
Emergency stop torque ^{d)}	T _{2not}	[Nm]	1 250	1 250	1 250	1 250	1 250	1 250	1 250	1 250	1 250	1 250	1 250
Efficiency	η	[%]	88										
Lifetime	L _h	[h]	> 20 000										
Weight	M	[kg]	22										
Angular backlash	j _t	[arcmin]	Precision P I ≤ 1 / P 3 ≤ 3 / P 5 ≤ 5 / P 12 ≤ 12										
Torsionnal rigidity ^{e)}	C _{t2}	[Nm/arcmin]	83.8	83.8	100.4	100.4	83.8	100.4	94.3	100.4	98.6	83.8	83.8
Noise ⁱ⁾	L _{pA}	[dB(A)]	≤ 71										
Max. permitted housing temperature ^{g)}	T	[°C]	90										
Protection class			IP 65										
Direction of rotation			Same way input / output										
Max. radial force on output shaft ^{f)}	F _{rmax}	[N]	Center of output shaft: 9 950 / End of output shaft: 6 700										
Max. axial force on output shaft ^{f)}	F _{amax}	[N]	10 300										
Color			Red, RAL 3003										
Inertia in kg·cm ² ^{h)}	Ø14	J ₁	[kg·cm ²]	6.83	5.42	5.28	5.22	3.51	4.11	3.47	3.46	3.46	3.44
	Ø19			6.83	5.42	5.28	5.22	3.51	4.11	3.47	3.46	3.46	3.44
	Ø24			7.84	6.43	6.29	6.23	4.52	5.12	4.48	4.47	4.47	4.45
	Ø32			10.04	8.63	8.49	8.43	6.72	7.32	6.68	6.67	6.67	6.65
	Ø35			12.87	11.46	11.32	11.26	9.55	10.15	9.51	9.50	9.50	9.48
	Ø38			18.06	16.65	16.51	16.45	14.74	15.34	14.70	14.69	14.69	14.67
	Ø42			17.66	16.25	16.11	16.05	14.34	14.94	14.30	14.29	14.29	14.27

* Other ratios available. 27, 48, 63, 84, 147 on request.

- a) Nominal output torque when operating at n_{1N}.
b) 1000 cycles per hour max.
c) Valid for an ambient temperature of 20°C and T_{2N}.
At higher ambient temperatures, please reduce speed.
d) Valid 1000 times the gearbox life.

e) Valid for an input Ø of 38 mm in 1-stage and 24 mm in 2- and 3-stage.

f) Values for 300 rpm.

g) For other temperatures, please contact us. Nominal output torque when operating at n_{1N}.

h) Depending on the motor output shaft Ø.

i) With n_{1N}=2500 rpm no load.

Rack

Rack for PR on request

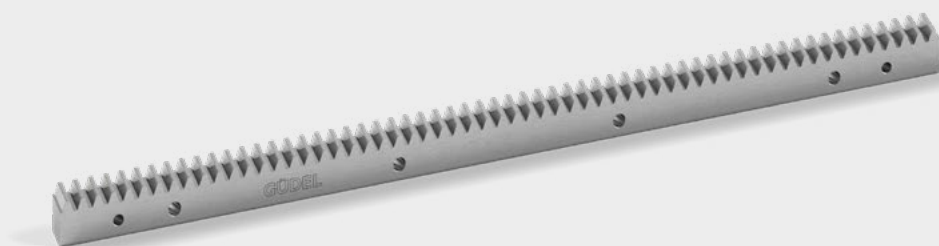

Input

A	for motor shaft	$L \leq 60$	$19 \leq \varnothing d \leq 32$	result in LA
B	for motor shaft	$60 < L \leq 85$	$32 < \varnothing d \leq 48$	result in LB
C	for motor shaft	$85 < L \leq 111$	$32 < \varnothing d \leq 48$	result in LC

		1-stage	2-stage	3-stage
LA	[mm]	168	220	273
LB	[mm]	193	246	298
LC	[mm]	219	272	

Output

Standard

Optional

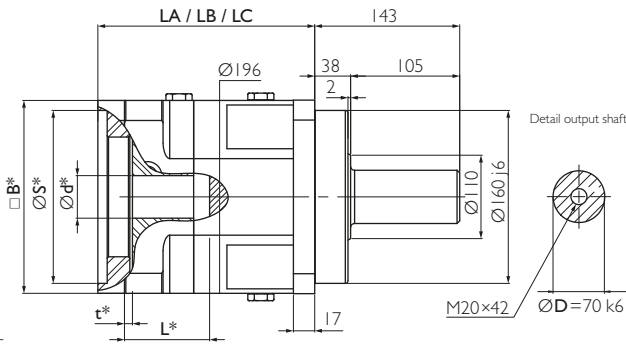
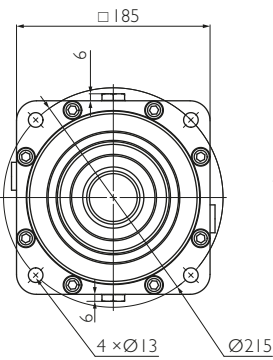

* depending on the motor. See pages 130 et seq.



Example PR 180 A1, 1-stage

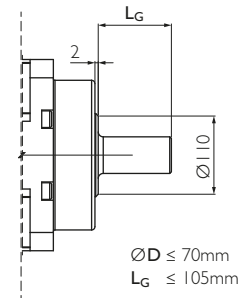

Detail output shaft

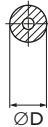

$\varnothing D \leq 70\text{mm}$
 $L_G \leq 105\text{mm}$

Option 3 on request. Adjustments can reduce capacity.

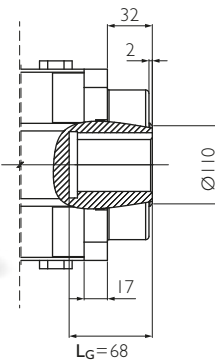

Detail output shaft

14 JS9

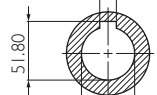

$\varnothing D = 48\text{ k6}$

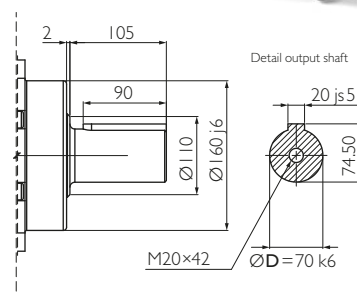

Detail output shaft

20 js5

74.50

$\varnothing D = 70\text{ k6}$

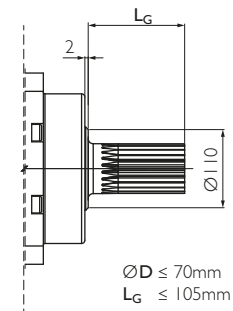

Detail output shaft



$\varnothing D \leq 70\text{mm}$
 $L_G \leq 105\text{mm}$

Option 5 on request. Adjustments can reduce capacity.

Your ideal drive train

Function Package with gearbox, rack and pinion from Güdel

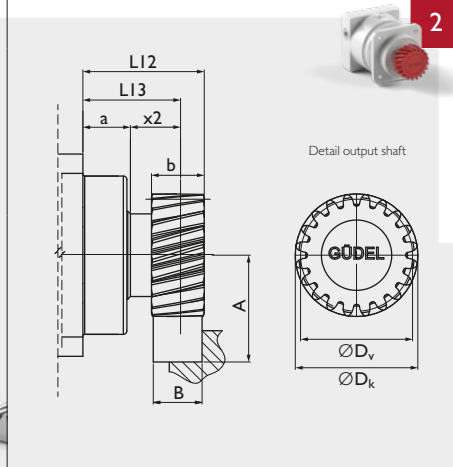
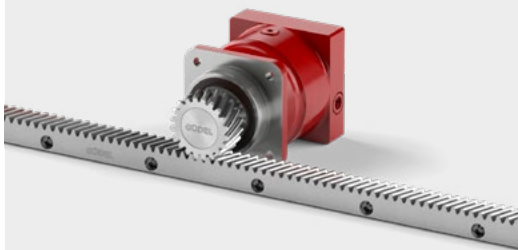

Detail output shaft

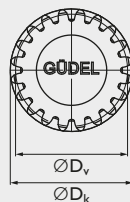

Pinion

Pinion for PR on request



Material 16MnCr5 DIN 1.7131
Teeth pressure angle $\alpha = 20^\circ$, helical teeth left, $19^\circ 31' 42''$ hardened (58⁺⁴ HRC), ground, crowned
Quality 6f24 DIN 3962 / 63 / 67

Available ratios	i		1-stage		2-stage				
			3	9	12	15	21	30	
Nominal torque S5 ^{a)}	T _{2N}	[Nm]	1 600	1 600	1 600	1 600	1 600	1 600	
Acceleration torque S5 ^{b)}	T _{2B}	[Nm]	1 925	1 900	1 900	1 900	1 900	1 900	
Nominal input speed S5 ^{c)}	n _{1N}	[rpm]	1 200	2 000	2 000	2 100	2 100	2 100	
Maximum input speed S5	n _{1max}	[rpm]	2 400	2 400	3 200	3 200	3 200	3 200	
Emergency stop torque ^{d)}	T _{2not}	[Nm]	3 000	3 000	3 000	3 000	3 000	3 000	
Efficiency	η	[%]	94	91					
Lifetime	L _h	[h]	> 20 000						
Weight	M	[kg]	32	39					
Angular backlash	j _t	[arcmin]	Precision P I ≤ 1 / P 3 ≤ 3 / P 5 ≤ 5 / P 12 ≤ 12						
Torsionnal rigidity ^{e)}	C _{t2}	[Nm/arcmin]	366.6	349.1	333.4	300.3	281.1	274.1	
Noise ⁱ⁾	L _{pA}	[dB(A)]	≤ 72						
Max. permitted housing temperature ^{g)}	T	[°C]	90						
Protection class			IP 65						
Direction of rotation			Same way input / output						
Max. radial force on output shaft ^{f)}	F _{rmax}	[N]	Center of output shaft: 18 000 / End of output shaft: 13 000						
Max. axial force on output shaft ^{f)}	F _{amax}	[N]	20 000						
Color			Red, RAL 3003						
Inertia in kg·cm ² ^{h)}	Ø19	J ₁	[kg·cm ²]	38.19	38.58	16.57	17.35	12.20	9.22
	Ø24			39.24	39.63	17.62	18.40	13.25	10.27
	Ø32			41.45	41.84	19.83	20.61	15.46	12.48
	Ø35			44.37	44.76	22.75	23.53	18.38	15.40
	Ø38			49.97	50.36	28.35	29.13	23.98	21.00
	Ø42			49.47	49.86	27.85	28.63	23.48	20.50
	Ø48			49.87	50.26	28.25	29.03	23.88	20.90

- a) Nominal output torque when operating at n_{1N}.
b) 1 000 cycles per hour max.
c) Valid for an ambient temperature of 20°C and T_{2N}.
At higher ambient temperatures, please reduce speed.
d) Valid 1 000 times the gearbox life.

- e) Valid for an input Ø of 48 mm in 1-stage and 38 mm in 2- and 3-stage.
f) Values for 300 rpm.
g) For other temperatures, please contact us. Nominal output torque when operating at n_{1N}.
h) Depending on the motor output shaft Ø.
i) With n_{1N}=2500 rpm no load.

Rack

Rack for PR on request

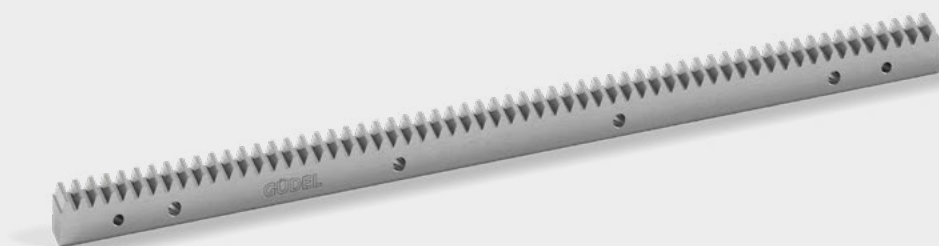

Input

A	for motor shaft	$L \leq 60$	$19 \leq \varnothing d \leq 32$	result in LA
B	for motor shaft	$60 < L \leq 85$	$32 < \varnothing d \leq 48$	result in LB
C	for motor shaft	$85 < L \leq 111$	$32 < \varnothing d \leq 48$	result in LC

		1-stage	2-stage	3-stage
LA	[mm]	168	220	273
LB	[mm]	193	246	298
LC	[mm]	219	272	

Output

Standard Optional

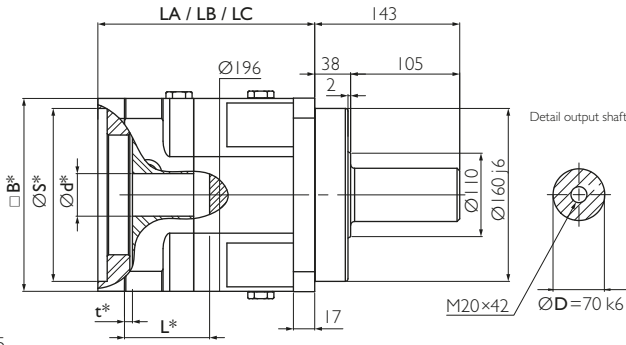
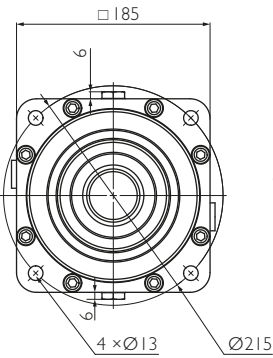

* depending on the motor. See pages 130 et seq.



Example PR 180 A4, 1-stage

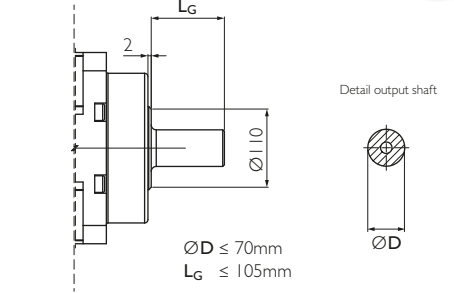

Option 3 on request. Adjustments can reduce capacity.

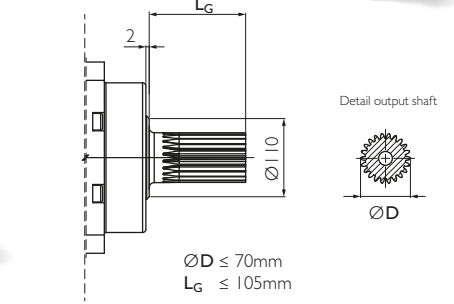
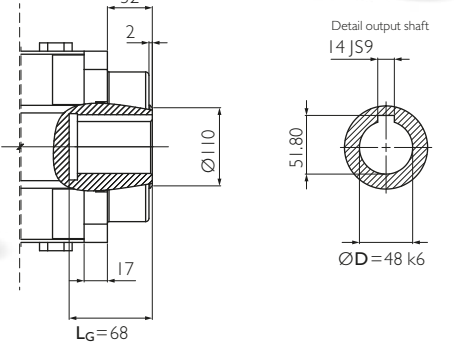

Option 5 on request. Adjustments can reduce capacity.

Your ideal drive train

Function Package with gearbox, rack and pinion from Güdel

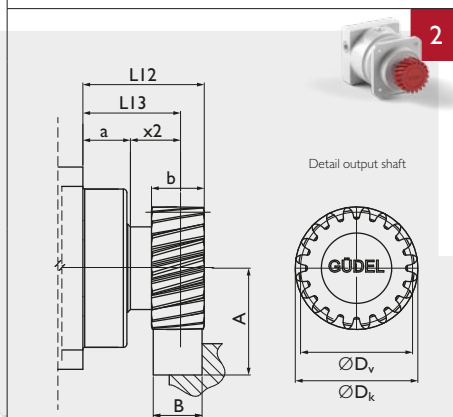
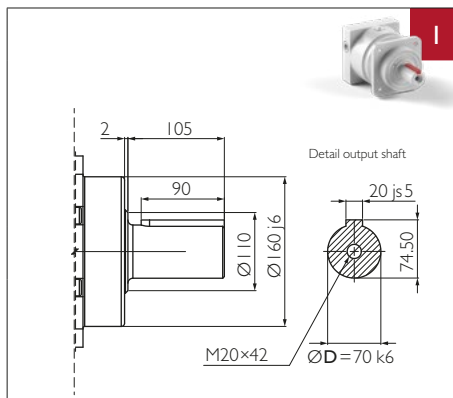
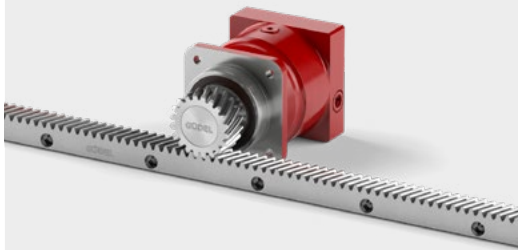

Material 16MnCr5 DIN 1.7131
 Teeth pressure angle $\alpha = 20^\circ$, helical teeth left, $19^\circ 31' 42''$ hardened (58⁺⁴HRC), ground, crowned
 Quality 6f24 DIN 3962 / 63 / 67

Pinion

Pinion for PR on request



Available ratios *	i		3-stage										
			36	45	60	75	90	105	120	150	210	300	
Nominal torque S5 a)	T _{2N}	[Nm]	1 600	1 600	1 600	1 600	1 600	1 600	1 600	1 600	1 600	1 600	1 600
Acceleration torque S5 b)	T _{2B}	[Nm]	1 900	1 900	1 900	1 900	1 900	1 900	1 900	1 900	1 900	1 900	1 900
Nominal input speed S5 c)	n _{1N}	[rpm]	2 200	2 700	2 700	2 700	2 700	2 700	2 700	2 700	2 700	2 700	2 700
Maximum input speed S5	n _{1max}	[rpm]	3 200	3 200	3 200	3 200	3 200	3 200	3 200	3 200	3 200	3 200	3 200
Emergency stop torque d)	T _{2not}	[Nm]	3 000	3 000	3 000	3 000	3 000	3 000	3 000	3 000	3 000	3 000	3 000
Efficiency	η	[%]	88										
Lifetime	L _h	[h]	> 20 000										
Weight	M	[kg]	46										
Angular backlash	j _t	[arcmin]	Precision P 1 ≤ 1 / P 3 ≤ 3 / P 5 ≤ 5 / P 12 ≤ 12										
Torsionnal rigidity e)	C _{t2}	[Nm/arcmin]	300.0	270.3	270.3	270.3	246.8	270.3	300.0	270.3	253.1	220.5	
Noise i)	L _{pA}	[dB(A)]	≤ 72										
Max. permitted housing temperature e)	T	[°C]	90										
Protection class			IP 65										
Direction of rotation			Same way input / output										
Max. radial force on output shaft f)	F _{rmax}	[N]	Center of output shaft: 18 000 / End of output shaft: 13 000										
Max. axial force on output shaft f)	F _{amax}	[N]	20 000										
Color			Red, RAL 3003										
Inertia in kg·cm ² h)	Ø19	J ₁	[kg·cm ²]	23.60	17.37	16.77	16.52	9.22	11.77	9.07	9.01	8.96	8.93
	Ø24			24.65	18.42	17.82	17.57	10.27	12.82	10.12	10.06	10.01	9.98
	Ø32			26.86	20.63	20.03	19.78	12.48	15.03	12.33	12.27	12.22	12.19
	Ø35			29.78	23.55	22.95	22.70	15.40	17.95	15.25	15.19	15.14	15.11
	Ø38			35.38	29.15	28.55	28.30	21.00	23.55	20.85	20.79	20.74	20.71
	Ø42			34.88	28.65	28.05	27.80	20.50	23.05	20.35	20.29	20.24	20.21
	Ø48			35.28	29.05	28.45	28.20	20.90	23.45	20.75	20.69	20.64	20.61

* Other ratios available. 27, 48, 63, 84, 147 on request.

- a) Nominal output torque when operating at n_{1N}.
b) 1 000 cycles per hour max.
c) Valid for an ambient temperature of 20°C and T_{2N}.
At higher ambient temperatures, please reduce speed.

- d) Valid 1000 times the gearbox life.
e) Valid for an input Ø of 48 mm in 1-stage and 38 mm in 2- and 3-stage.
f) Values for 300 rpm.
g) For other temperatures, please contact us. Nominal output torque when operating at n_{1N}.
h) Depending on the motor output shaft Ø.
i) With n_{1N}=2500 rpm no load.

Rack

Rack for PR on request

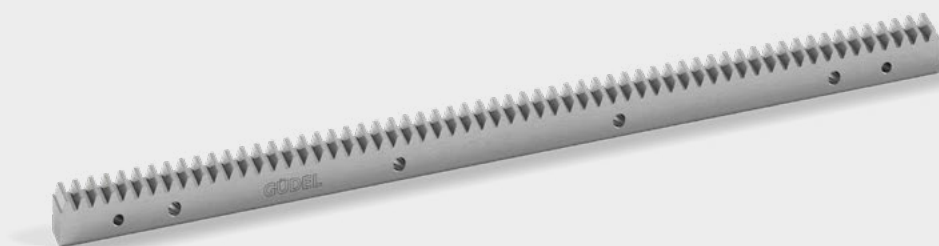

Input

A	for motor shaft	$L \leq 85$	$24 \leq \varnothing d \leq 48$	result in LA
B	for motor shaft	$85 < L \leq 115$	$48 < \varnothing d \leq 55$	result in LB

		1-stage	2-stage	3-stage
LA	[mm]	229	300	371
LB	[mm]	259	330	

Output

0	Optional	3
----------	----------	----------

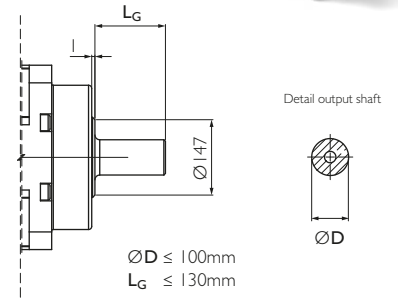

Option 3 on request. Adjustments can reduce capacity.

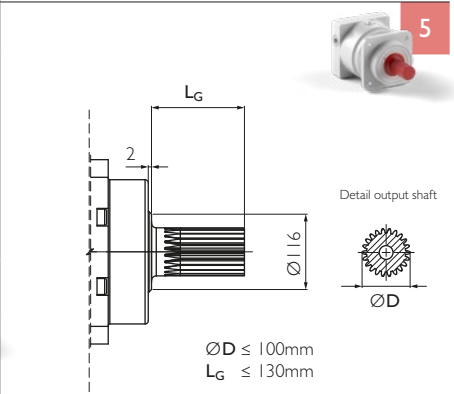
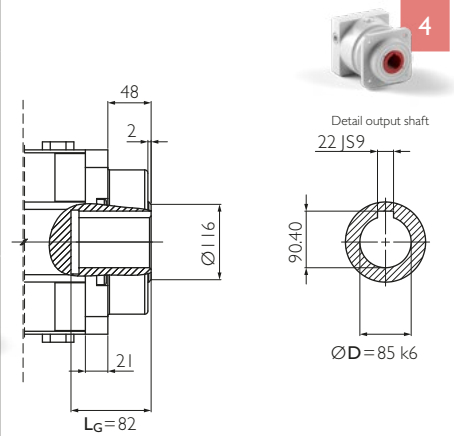

Option 5 on request. Adjustments can reduce capacity.

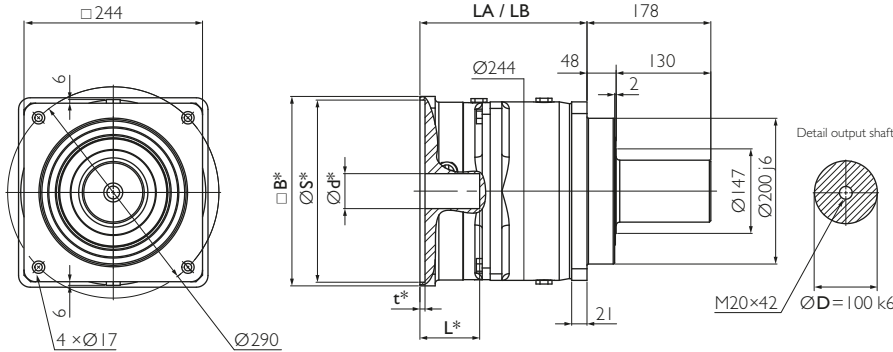

* depending on the motor. See pages 130 et seq.

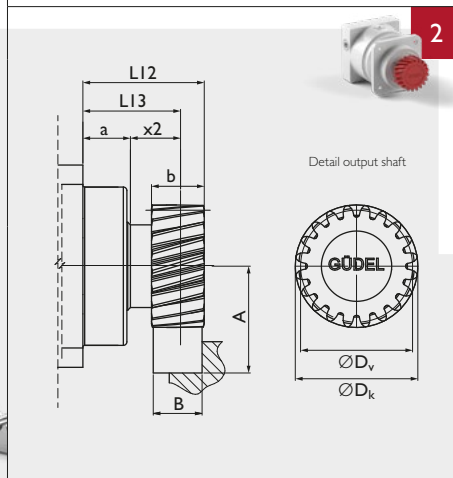
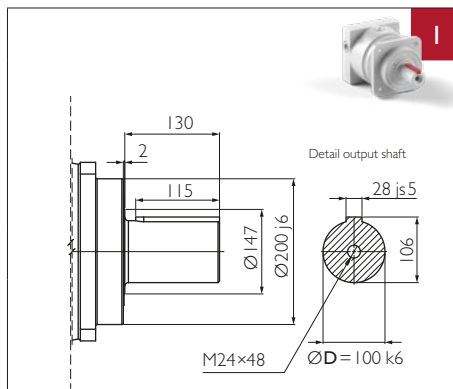

Example PR 240 A5, 1-stage

Your ideal drive train

Function Package with gearbox, rack and pinion from Güdel

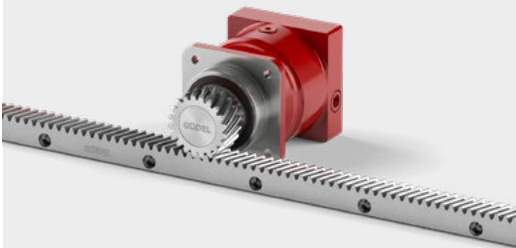

Pinion

Pinion for PR on request



Material 16MnCr5 DIN 1.7131
 Teeth pressure angle $\alpha = 20^\circ$, helical teeth left, $19^\circ 31' 42''$ hardened (58⁺⁴ HRC), ground, crowned
 Quality 6f24 DIN 3962 / 63 / 67

Available ratios	i		1-stage		2-stage				
			3	9	12	15	21	30	
Nominal torque S5 ^{a)}	T _{2N}	[Nm]	4 400	4 400	4 400	4 400	4 400	4 400	
Acceleration torque S5 ^{b)}	T _{2B}	[Nm]	5 600	5 600	5 600	5 600	5 600	5 600	
Nominal input speed S5 ^{c)}	n _{1N}	[rpm]	800	800	1 400	1 500	1 500	1 500	
Maximum input speed S5	n _{1max}	[rpm]	1 600	1 600	2 800	2 800	2 800	2 800	
Emergency stop torque ^{d)}	T _{2not}	[Nm]	8 500	8 500	8 500	8 500	8 500	8 500	
Efficiency	η	[%]	94	91					
Lifetime	L _h	[h]	> 20 000						
Weight	M	[kg]	70	90					
Angular backlash	j _t	[arcmin]	Precision P I ≤ 1 / P 3 ≤ 3 / P 5 ≤ 5 / P 12 ≤ 12						
Torsionnal rigidity ^{e)}	C _{t2}	[Nm/arcmin]	814.7	730.3	756.6	779.8	805.9	736.1	
Noise ⁱ⁾	L _{pA}	[dB(A)]	≤ 74						
Max. permitted housing temperature ^{g)}	T	[°C]	90						
Protection class			IP 65						
Direction of rotation			Same way input / output						
Max. radial force on output shaft ^{f)}	F _{rmax}	[N]	Center of output shaft: 37 500 / End of output shaft: 25 000						
Max. axial force on output shaft ^{f)}	F _{amax}	[N]	34 000						
Color			Red, RAL 3003						
Inertia in kg.cm ² h)	Ø24	J ₁	[kgcm ²]	161.0	146.0	79.1	55.0	35.4	23.6
	Ø32			163.2	148.2	81.3	57.2	37.6	25.8
	Ø35			168.5	153.5	86.6	62.5	42.9	31.1
	Ø38			171.9	156.9	90.0	65.9	46.3	34.5
	Ø42			171.4	156.4	89.5	65.4	45.8	34.0
	Ø48			171.6	156.6	89.7	65.6	46.0	34.2
	Ø55			194.2	179.2	112.3	88.2	68.6	56.8

- a) Nominal output torque when operating at n_{1N}.
b) 1 000 cycles per hour max.
c) Valid for an ambient temperature of 20°C and T_{2N}.
At higher ambient temperatures, please reduce speed.
d) Valid 1 000 times the gearbox life.

- e) Valid for an input Ø of 55 mm in 1-stage and 48 mm in 2- and 3-stage.
f) Values for 300 rpm.
g) For other temperatures, please contact us. Nominal output torque when operating at n_{1N}.
h) Depending on the motor output shaft Ø.
i) With n_{1N}=1 800 rpm no load.

Rack

Rack for PR on request

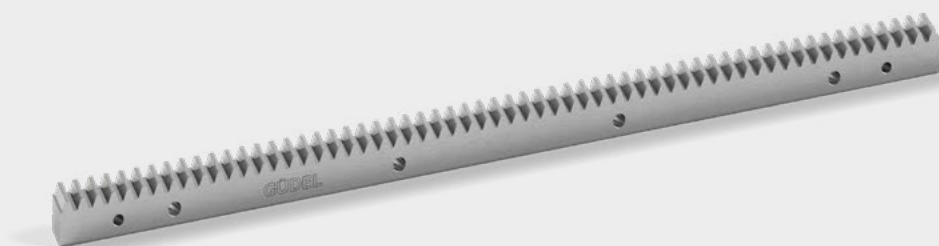

Input

A	for motor shaft	$L \leq 85$	$24 \leq \varnothing d \leq 48$	result in LA
B	for motor shaft	$85 < L \leq 115$	$48 < \varnothing d \leq 55$	result in LB

Output

Standard

Optional

		1-stage	2-stage	3-stage
LA	[mm]	229	300	371
LB	[mm]	259	330	

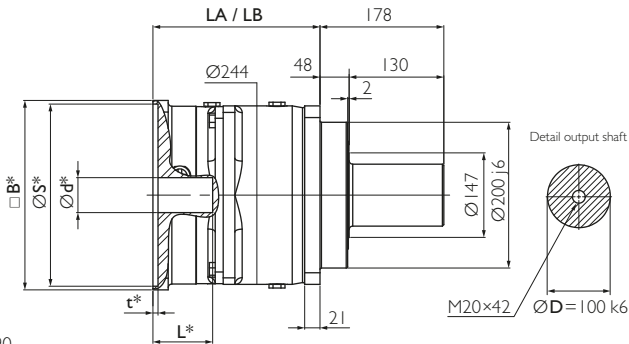
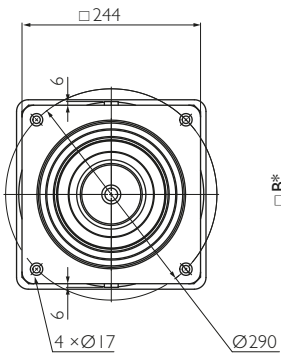

* depending on the motor. See pages 130 et seq.

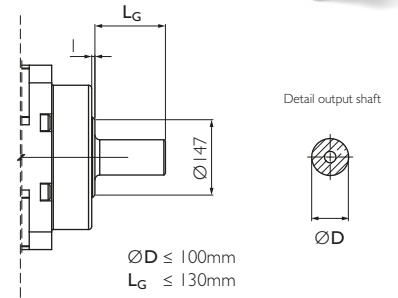

Option 3 on request. Adjustments can reduce capacity.

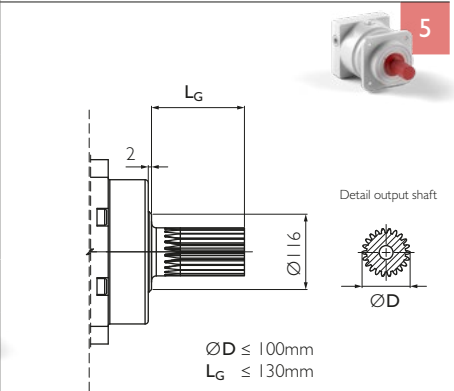
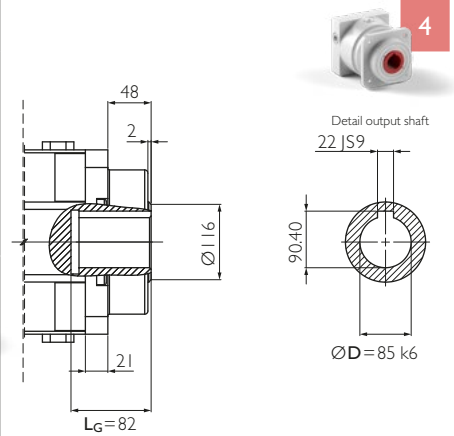

Option 5 on request. Adjustments can reduce capacity.

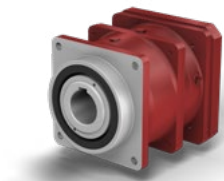

Example PR 240 B4, 1-stage

Your ideal drive train

Function Package with gearbox, rack and pinion from Güdel

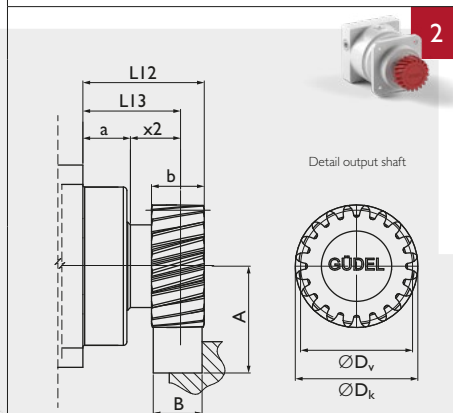
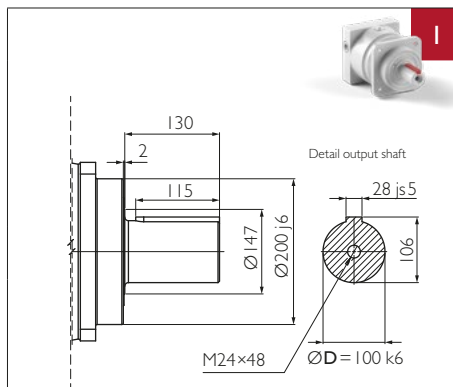
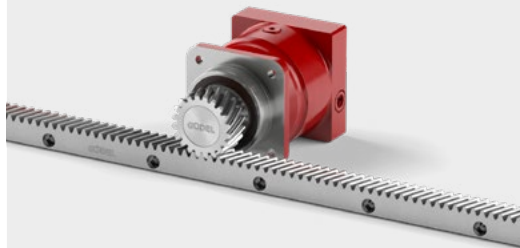

Material 16MnCr5 DIN 1.7131
 Teeth pressure angle $\alpha = 20^\circ$, helical teeth left, $19^\circ 31' 42''$ hardened (58⁺⁴HRC), ground, crowned
 Quality 6f24 DIN 3962 / 63 / 67

Pinion

Pinion for PR on request



Available ratios *	i		3-stage										
			36	45	60	75	90	105	120	150	210	300	
Nominal torque S5 ^{a)}	T _{2N}	[Nm]	4 400	4 400	4 400	4 400	4 400	4 400	4 400	4 400	4 400	4 400	4 400
Acceleration torque S5 ^{b)}	T _{2B}	[Nm]	5 600	5 600	5 600	5 600	5 600	5 600	5 600	5 600	5 600	5 600	5 600
Nominal input speed S5 ^{c)}	n _{1N}	[rpm]	1 600	1 900	1 900	1 900	1 900	1 900	1 900	1 900	1 900	1 900	1 900
Maximum input speed S5	n _{1max}	[rpm]	2 800	2 800	2 800	2 800	2 800	2 800	2 800	2 800	2 800	2 800	2 800
Emergency stop torque ^{d)}	T _{2not}	[Nm]	8 500	8 500	8 500	8 500	8 500	8 500	8 500	8 500	8 500	8 500	8 500
Efficiency	η	[%]	88										
Lifetime	L _h	[h]	> 20 000										
Weight	M	[kg]	110										
Angular backlash	j _t	[arcmin]	Precision P I ≤ 1 / P 3 ≤ 3 / P 5 ≤ 5 / P 12 ≤ 12										
Torsionnal rigidity ^{e)}	C _{t2}	[Nm/arcmin]	680.9	701.3	660.6	701.3	660.6	701.3	680.9	692.6	718.8	660.6	
Noise ⁱ⁾	L _{pA}	[dB(A)]	≤ 74										
Max. permitted housing temperature ^{g)}	T	[°C]	90										
Protection class			IP 65										
Direction of rotation			Same way input / output										
Max. radial force on output shaft ^{f)}	F _{rmax}	[N]	Center of output shaft: 37 500 / End of output shaft: 25 000										
Max. axial force on output shaft ^{f)}	F _{amax}	[N]	34 000										
Color			Red, RAL 3003										
Inertia in kg·cm ² ^{h)}	Ø24	J ₁	[kg·cm ²]	78.6	55.0	78.2	54.6	23.5	35.1	23.4	23.4	23.4	22.3
	Ø32			80.8	57.2	80.4	56.8	25.7	37.3	25.6	25.6	25.6	24.5
	Ø35			86.1	62.5	85.7	62.1	31.0	42.6	30.9	30.9	30.9	29.8
	Ø38			89.5	65.9	89.1	65.5	34.4	46.0	34.3	34.3	34.3	33.2
	Ø42			89.0	65.4	88.6	65.0	33.9	45.5	33.8	33.8	33.8	32.7
	Ø48			89.2	65.6	88.8	65.2	34.1	45.7	34.0	34.0	34.0	32.9
	Ø55			111.8	88.2	111.4	87.8	56.7	68.3	56.6	56.6	56.6	55.5

* Other ratios available. 27, 48, 63, 84, 147 on request.

- a) Nominal output torque when operating at n_{1N}.
b) 1000 cycles per hour max.
c) Valid for an ambient temperature of 20°C and T_{2N}.
At higher ambient temperatures, please reduce speed.

d) Valid 1000 times the gearbox life.

e) Valid for an input Ø of 55 mm in 1-stage and 48 mm in 2- and 3-stage.

f) Values for 300 rpm.

g) For other temperatures, please contact us. Nominal output torque when operating at n_{1N}.

h) Depending on the motor output shaft Ø.

i) With n_{1N}=1800 rpm no load.

Rack

Rack for PR on request

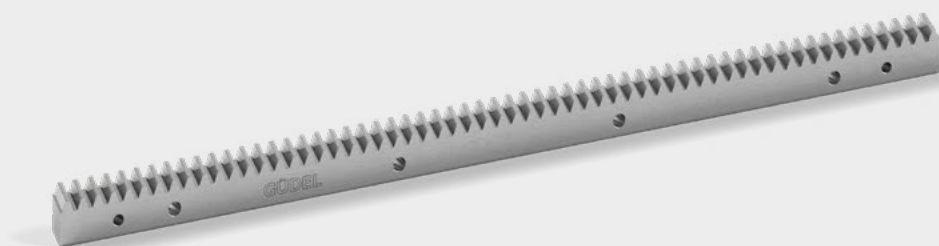

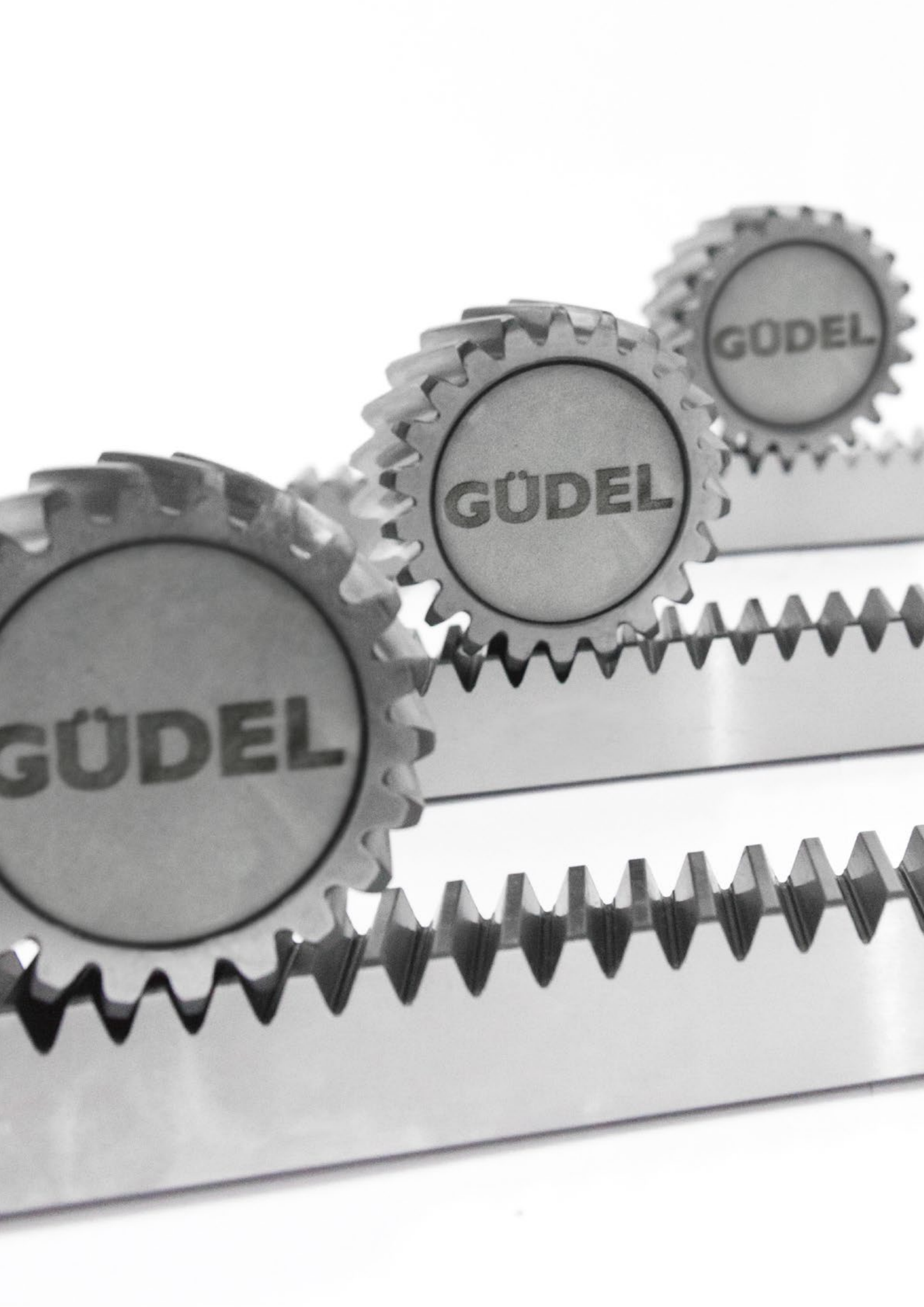
A black and white photograph of three interlocking gears. The gears are arranged in a diagonal line from the bottom left to the top right. Each gear has the word "GÜDEL" printed in a bold, sans-serif font on its central circular face. The gears are meshed together, and the teeth are clearly visible. The background is a plain, light color.

GÜDEL

GÜDEL

GÜDEL

Your ideal drive train

GÜDEL

Rack & pinion programm

Our function package for your ideal drive train with gearbox, rack and pinion from Güdel.



Pinion

<p>Helical tooth, modular pitch</p>	<p>Hardened and ground</p> <p>Material 16MnCr5 DIN 1.7131</p> <p>Teeth pressure angle $\alpha = 20^\circ$ helical teeth left, $19^\circ 31' 42''$ hardened (58^{+1}_0HRC) ground, crowned</p> <p>Quality 6f24 DIN 3962/63/67</p> <p>* Tolerances AG Size 080 AG ± 0.05 Size 100 AG ± 0.06 Size 140 AG ± 0.08</p>
--	--

Geometrical data

	Size	m_n	P_t	z	A	A_G	b	D_k	D_0	D_v	L12	L13	x2	a	M
NRH/ SR	080	2	6.66	20	43.221	–	25	46.44	42.441	42.441	52.5	40.0	20.0	20	0.3
		2.5	8.33	16	43.471	–	25	48.94	42.441	43.941	52.5	40.0	20.0	20	0.3
	100	2	6.66	25	48.526	–	25	57.05	53.052	53.052	63.3	51.0	24.0	27	0.4
		3	10.00	20	57.831	–	30	69.66	63.662	63.662	69.0	54.0	27.0	27	0.7
	140	3	10.00	22	61.014	–	30	76.03	70.028	70.028	69.5	54.5	27.5	27	0.8
4		13.33	20	77.441	–	40	92.88	84.883	84.883	79.0	59.0	32.0	27	1.6	
NRHP	080	2	6.66	16	39.577	–	26	39.15	33.953	35.153	75.0	62.0	32.0	30	0.6
		2	6.66	16	39.577	–	26	39.15	33.953	35.153	77.0	64.0	35.0	29	1.0
	100	2	6.66	21	44.282	–	26	48.56	44.563	44.563	77.0	64.0	35.0	29	1.0
		2.5	8.33	16	43.471	–	26	48.94	42.441	43.941	77.0	64.0	35.0	29	1.0
		3	10.00	14	49.182	–	32	52.36	44.563	46.363	83.0	67.0	38.0	29	1.2
	140	2.5	8.33	21	49.352	–	26	60.70	55.704	55.704	89.0	76.0	38.0	38	1.9
		3	10.00	18	54.648	–	32	63.30	57.296	57.296	95.0	79.0	41.0	38	2.0
NGHP	080	2	6.66	20	43.221	45.721	25	46.44	42.441	42.441	57.0	44.5	14.5	30	0.3
		2.5	8.33	16	43.471	45.971	25	48.94	42.441	43.941	57.0	44.5	14.5	30	0.3
	100	2	6.66	25	48.526	51.526	25	57.05	53.052	53.052	57.0	44.5	15.5	29	0.4
		3	10.00	20	57.831	60.831	30	69.66	63.662	63.662	62.0	47.0	18.0	29	0.7
	140	3	10.00	22	61.014	65.014	30	76.03	70.028	70.028	72.0	57.0	19.0	38	0.8
		4	13.33	20	77.441	81.441	40	92.88	84.883	84.883	82.0	62.0	24.0	38	1.6
NR	180	4	13.33	20	77.441	–	40	92.88	84.883	84.883	83.5	63.5	31.5	32	1.5
		5	16.66	20	87.052	–	50	116.10	106.103	106.103	89.5	64.5	32.5	32	3.0
	240	5	16.66	24	97.662	–	50	137.32	127.324	127.324	112.5	87.5	47.5	40	5.4
		6	20.00	20	106.662	–	60	139.32	127.324	127.324	111.0	81.0	41.0	40	5.6
SR	180	4	13.33	20	77.441	–	40	92.88	84.883	84.883	89.5	69.5	31.5	38	1.5
		5	16.66	20	87.052	–	50	116.10	106.103	106.103	95.5	70.5	32.5	38	3.0
	240	5	16.66	24	97.662	–	50	137.32	127.324	127.324	120.5	95.5	47.5	48	5.4
		6	20.00	20	106.662	–	60	139.32	127.324	127.324	119.0	89.0	41.0	48	5.6

m_n : Normal module, P_t : Transverse pitch [mm], z : Number of teeth, A_G : Gearbox position, D_0 : Pitch circle diameter for calculation, D_v : Pitch circle diameter for design, M : Weight [kg]

Rack

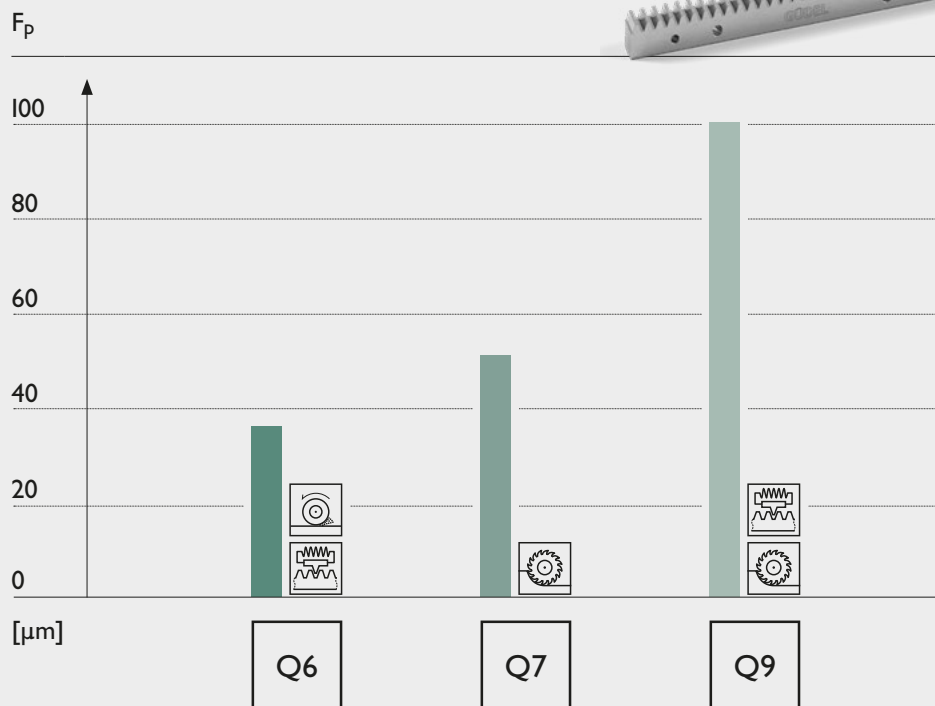
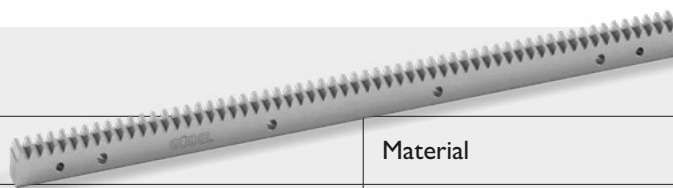

Material



Steel

Processes



Hardened



Milled



Ground



Helical

Example of the cumulative pitch deviation F_p for module 4 based on length 1000mm. Quality DIN 3962.

Geometrical data

Size	m_n	P_t	L	z	b	h
080 100	2	6.66	500.00	75	24	24
			1000.00	150		
			2000.00	300		
080 100 140	2.5	8.33	500.00	60	24	24
			1000.00	120		
			2000.00	240		
100 140	3	10.00	500.00	50	29	29
			1000.00	100		
			2000.00	200		
140 180	4	13.33	506.67	38	39	39
			1000.00	75		
			2000.00	150		
180 240	5	16.66	500.00	30	49	39
			1000.00	60		
			2000.00	120		
240	6	20.00	500.00	25	59	49
			1000.00	50		
			2000.00	100		

Q6
Part No.
246022
246023
246024
246032
246033
246034
246042
246043
246044
246055
246056
246057
246062
246063
246064
246072
246073
246074

Page | 22

Q6+*
Part No.
246122
246123
246124
246132
246133
246134
246142
246143
246144
246152
246153
246154
246162
246163
246164
246172
246173
246174

Page | 23

Q7
Part No.
155022
155023
155024
155032
155033
155034
155042
155043
155044
155052
155053
155054
155062
155063
155064
-
-
-

Page | 24

Q9
Part No.
158022
158023
158024
158032
158033
158034
158042
158043
158044
158052
158053
158054
158062
158063
158064
158072
158073
158074

Page | 25

m_n : Normal module, P_t : Transverse pitch [mm], z: Number of teeth
 * Double amount of fixing holes for maximum feed force

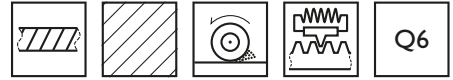

Helical teeth, modular pitch



Hardened and ground

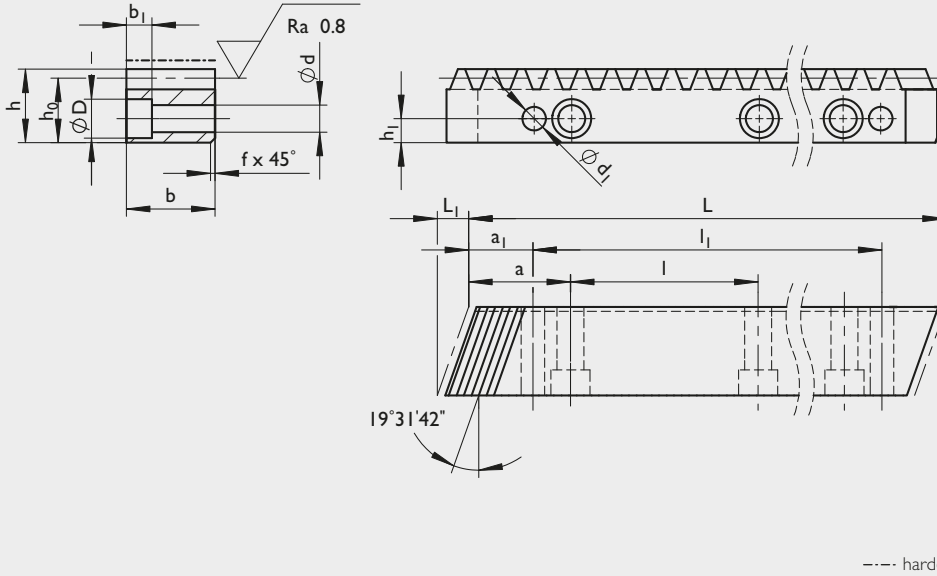

Material
C45E DIN 1.1191

Profile
all faces ground

Teeth
pressure angle $\alpha = 20^\circ$
helical teeth system right
helix angle $\beta = 19^\circ 31' 42''$
hardened (54⁺⁴HRC)
and ground

Quality
6h23 DIN 3962/63/67

p_f [mm]
cut-to-length tolerance for
continuous mounting -0.05/-0.50

F_{pL} [mm]
cumulative pitch deviation
based on length L

--- hardened



Geometrical data

Size	m _n	p _t	L	L ₁	z	b	h	h ₀	f±0,5	a	l	h ₁	d	D	b ₁	a ₁	l ₁	d ₁	F _{pL}	M	Part No.
080 100	2	6.66	500.00	8.5	75	24	24	22.0	2	62.5	125	8	7	11	7	31.7	436.6	5.7	0.025	2.0	246022
			1000.00		150												936.6		0.036	4.0	246023
			2000.00		300												1936.6		0.058	8.0	246024
080 100 140	2.5	8.33	500.00	8.5	60	24	24	21.5	2	62.5	125	9	7	11	7	31.7	436.6	5.7	0.027	1.9	246032
			1000.00		120												936.6		0.036	3.9	246033
			2000.00		240												1936.6		0.053	7.7	246034
100 140	3	10.00	500.00	10.3	50	29	29	26.0	2	62.5	125	9	10	15	9	35.0	430.0	7.7	0.028	2.8	246042
			1000.00		100												930.0		0.037	5.6	246043
			2000.00		200												1930.0		0.054	11.2	246044
140 180	4	13.33	506.67	13.8	38	39	39	35.0	2	62.5	125	12	12	18	11	33.3	433.0	9.7	0.030	5.1	246055
			1000.00		75												933.4		0.036	10.1	246056
			2000.00		150												1933.4		0.050	20.2	246057
180 240	5	16.66	500.00	17.4	30	49	39	34.0	3	62.5	125	12	14	20	13	37.5	425.0	11.7	0.028	6.0	246062
			1000.00		60												925.0		0.034	12.0	246063
			2000.00		120												1925.0		0.045	24.1	246064
240	6	20.00	500.00	20.9	25	59	49	43.0	3	62.5	125	16	18	26	17	37.5	425.0	15.7	0.031	8.9	246072
			1000.00		50												925.0		0.036	18.0	246073
			2000.00		100												1925.0		0.046	36.2	246074

m_n: Normal module, P_t: Transverse pitch [mm], z: Number of teeth, d₁: Predrilled, M: Weight [kg]

Rack – Helical teeth

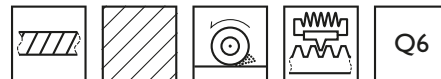

Helical teeth, modular pitch



Hardened and ground

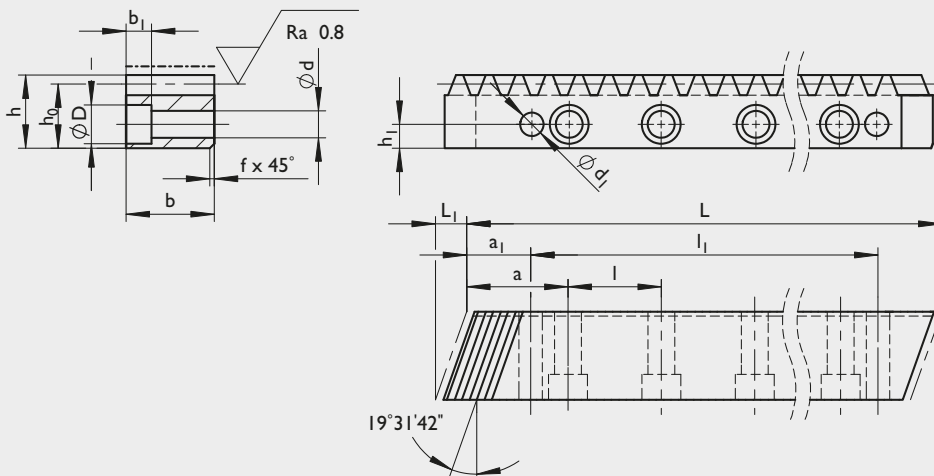

--- hardened

Material
C45E DIN 1.1191

Profile
all faces ground

Teeth
pressure angle $\alpha = 20^\circ$
helical teeth system right
helix angle $\beta = 19^\circ 31' 42''$
hardened (54⁺⁴ HRC)
and ground

Quality
6h23 DIN 3962/63/67

p_f [mm]
cut-to-length tolerance for
continuous mounting -0.05/-0.50

F_{pL} [mm]
cumulative pitch deviation
based on length L



Geometrical data

Size	m _n	p _t	L	L _l	z	b	h	h ₀	f+0,5	a	l	h _l	d	D	b _l	a _l	l _l	d _l	F _{pL}	M	Part No.
080 100	2	6.66	500.00	8.5	75	24	24	22.0	2	62.5	62.5	8	7	11	7	31.7	436.6	5.7	0.025	2.0	246122
			1000.00		150												936.6		0.036	3.9	246123
			2000.00		300												1936.6		0.058	7.8	246124
080 100 140	2.5	8.33	500.00	8.5	60	24	24	21.5	2	62.5	62.5	9	7	11	7	31.7	436.6	5.7	0.027	1.9	246132
			1000.00		120												936.6		0.036	3.8	246133
			2000.00		240												1936.6		0.053	7.6	246134
100 140	3	10.00	500.00	10.3	50	29	29	26.0	2	62.5	62.5	9	10	15	9	35.0	430.0	7.7	0.028	2.7	246142
			1000.00		100												930.0		0.037	5.4	246143
			2000.00		200												1930.0		0.054	10.8	246144
140 180	4	13.33	506.67	13.8	38	39	39	35.0	2	62.5	62.5	12	12	18	11	33.3	433.0	9.7	0.030	4.9	246152
			1000.00		75												933.4		0.036	9.7	246153
			2000.00		150												1933.4		0.050	19.5	246154
180 240	5	16.66	500.00	17.4	30	49	39	34.0	3	62.5	62.5	12	14	20	13	37.5	425.0	11.7	0.028	5.8	246162
			1000.00		60												925.0		0.034	11.5	246163
			2000.00		120												1925.0		0.045	23.0	246164
240	6	20.00	500.00	20.9	25	59	49	43.0	3	62.5	62.5	16	18	26	17	37.5	425.0	15.7	0.031	8.5	246172
			1000.00		50												925.0		0.036	16.9	246173
			2000.00		100												1925.0		0.046	33.9	246174

m_n: Normal module, P_t: Transverse pitch [mm], z: Number of teeth, d_l: Predrilled, M: Weight [kg]



Module

Rack – Helical teeth



Helical teeth, modular pitch



Milled

Material
42CrMo4 DIN 1.7225 I

Profile
all faces milled

Teeth
pressure angle $\alpha = 20^\circ$
helical teeth system right
helix angle $\beta = 19^\circ 31' 42''$
milled

Quality
7h25 DIN 3962/63/67

pr [mm]
cut-to-length tolerance for
continuous mounting -0.05/-0.50

F_{pL} [mm]
cumulative pitch deviation
based on length L

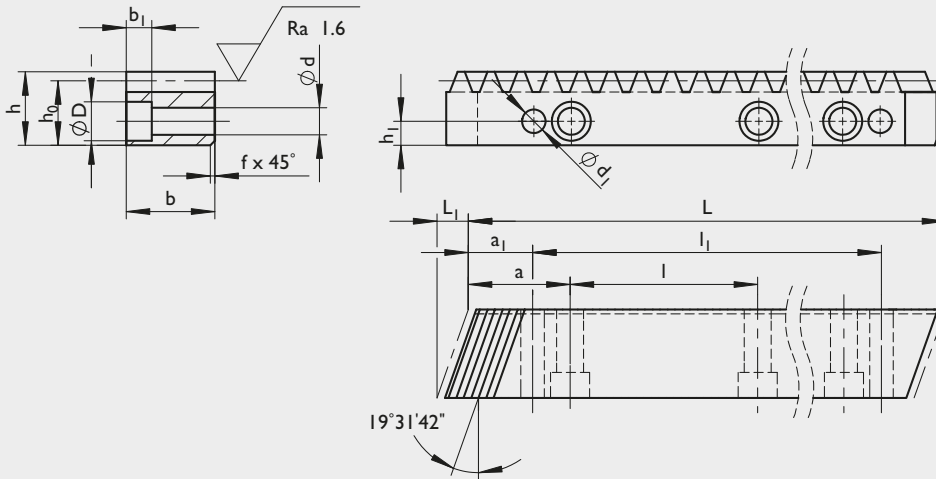

Geometrical data

Size	m _n	P _t	L	L ₁	z	b	h	h ₀	f+0,5	a	l	h ₁	d	D	b ₁	a ₁	l ₁	d ₁	F _{pL}	M	Part No.
080 100	2	6.66	500.00	8.5	75	24	24	22.0	I	62.5	125	8	7	11	7	31.7	436.6	5.7	0.036	2.0	155022
			1000.00		150												936.6		0.050	4.0	155023
			2000.00		300												1936.6		0.077	8.0	155024
080 100 140	2.5	8.33	500.00	8.5	60	24	24	21.5	I	62.5	125	9	7	11	7	31.7	436.6	5.7	0.038	1.9	155032
			1000.00		120												936.6		0.050	3.9	155033
			2000.00		240												1936.6		0.075	7.7	155034
100 140	3	10.00	500.00	10.3	50	29	29	26.0	I	62.5	125	9	10	15	9	35.0	430.0	7.7	0.040	2.8	155042
			1000.00		100												930.0		0.051	5.6	155043
			2000.00		200												1930.0		0.073	11.2	155044
140 180	4	13.33	506.67	13.8	38	39	39	35.0	I	62.5	125	12	12	18	11	33.3	433.0	9.7	0.042	5.1	155052
			1000.00		75												933.4		0.051	10.1	155053
			2000.00		150												1933.4		0.070	20.2	155054
180 240	5	16.66	500.00	17.4	30	49	39	34.0	I	62.5	125	12	14	20	13	37.5	425.0	11.7	0.040	6.0	155062
			1000.00		60												925.0		0.048	12.0	155063
			2000.00		120												1925.0		0.062	24.1	155064

m_n: Normal module, P_t: Transverse pitch [mm], z: Number of teeth, d₁: Predrilled, M: Weight [kg]

Rack – Helical teeth

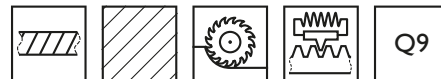
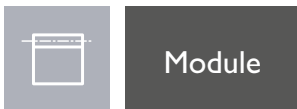

Helical teeth, modular pitch



Milled and hardened

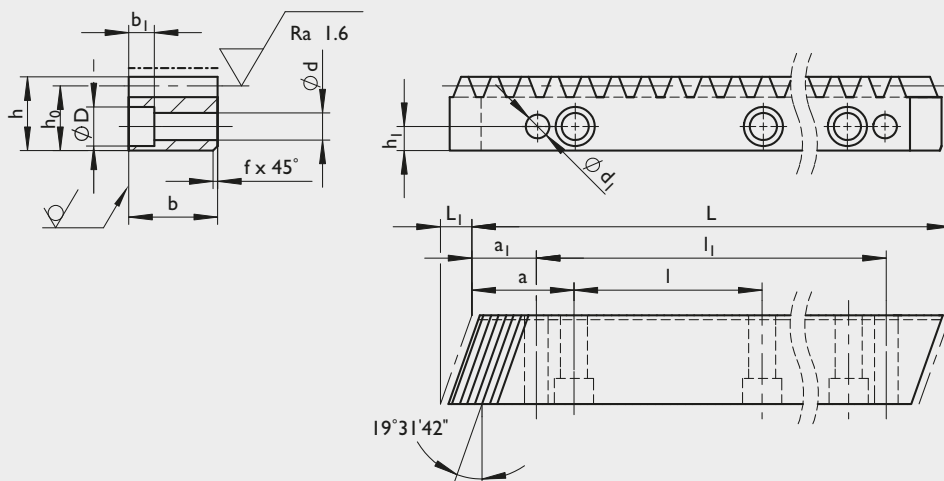

--- hardened

Material
C45E DIN 1.1191

Profile
all faces milled

Teeth
pressure angle $\alpha = 20^\circ$
helical teeth system right
helix angle $\beta = 19^\circ 31' 42''$
hardened (54⁺⁴HRC)
milled

Quality
9h27 DIN 3962/63/67

p_f [mm]
cut-to-length tolerance for
continuous mounting -0.05/-0.50

F_{pL} [mm]
cumulative pitch deviation
based on length L



Geometrical data

Size	m _n	p _t	L	L ₁	z	b	h	h ₀	f+0,5	a	l	h ₁	d	D	b ₁	a ₁	l ₁	d ₁	F _{pL}	M	Part No.
080 100	2	6.66	500.00	8.5	75	24	24	22.0	2	62.5	125	8	7	11	7	31.7	436.6	5.7	0.073	2.0	158022
			1000.00		150												936.6		0.100	4.0	158023
			2000.00		300												1936.6		0.155	8.0	158024
080 100 140	2.5	8.33	500.00	8.5	60	24	24	21.5	2	62.5	125	9	7	11	7	31.7	436.6	5.7	0.076	1.9	158032
			1000.00		120												936.6		0.101	3.9	158033
			2000.00		240												1936.6		0.150	7.7	158034
100 140	3	10.00	500.00	10.3	50	29	29	26.0	2	62.5	125	9	10	15	9	35.0	430.0	7.7	0.080	2.8	158042
			1000.00		100												930.0		0.103	5.6	158043
			2000.00		200												1930.0		0.147	11.2	158044
140 180	4	13.33	506.67	13.8	38	39	39	35.0	2	62.5	125	12	12	18	11	33.3	433.0	9.7	0.083	5.1	158052
			1000.00		75												933.4		0.101	10.1	158053
			2000.00		150												1933.4		0.136	20.2	158054
180 240	5	16.66	500.00	17.4	30	49	39	34.0	3	62.5	125	12	14	20	13	37.5	425.0	11.7	0.080	6.0	158062
			1000.00		60												925.0		0.094	12.0	158063
			2000.00		120												1925.0		0.122	24.1	158064
240	6	20.00	500.00	20.9	25	59	49	43.0	3	62.5	125	16	18	26	17	37.5	425.0	15.7	0.087	8.9	158072
			1000.00		50												925.0		0.101	18.0	158073
			2000.00		100												1925.0		0.128	36.2	158074

m_n: Normal module, P_t: Transverse pitch [mm], z: Number of teeth, d₁: Predrilled, M: Weight [kg]



Technical information

GÜDEL

Generate the code of your planetary gearbox

Type **NRH** Size **100** - Ratio **4** - Configuration **A 0**

- NRH
- NRHP
- NGHP
- NR
- SR
- PR

- 080
- 100
- 140
- 180
- 240

- A Small
- B Medium
- C Long

- 0 Smooth
- 1 Keyway
- 3 Custom
- 4 Hollow
- 5 Spline

2 Pinion

Add x for special gearbox. Not defined in the standard reference. A unique study number will be assigned.

NRH 100

Output shafts (excl. output pinion)

D32 - **L58**

D Diameter [mm] L Shaft length [mm]

The screenshot shows the GÜDEL software interface for configuring a planetary gearbox. It includes a 3D model of the gearbox, a table of technical specifications, and a 'Your ideal drive train' section. The interface is titled 'NRH 100 1-stage Planetary gearboxes'.

Output Pinion

z20 - **m3H**

z Number of teeth m Module

- H Helical teeth
- S Straight teeth

This block contains several technical datasheets for the NRH 100 planetary gearbox. The sheets include:

- General specifications and dimensions.
- Technical drawings of the gearbox housing and internal components.
- Performance curves and tables for torque, speed, and efficiency.
- Material specifications and surface treatments.
- Assembly and maintenance instructions.

 The datasheets are presented in a collage format, with some overlapping to show different views and details.

See technical datasheets on pages 30 et seq.



Example
NRH100-4-A0-D32-L58-TP-P3-AM

Position

TP

- HI Horizontal
- VI Upright
- V2 Downside
- TP All positions*

*Add B for option breather: reduces the pressure in S1.

Precision

P3

P Precision [arcmin]

Input

AM

- AM Motor adaptation
- AC Keyway shaft
- AL Smooth shaft

Motor

Planetary gearboxes

Series	Ratio	Output
NRH100	100	100
NRH100	100	200
NRH100	100	300
NRH100	100	400
NRH100	100	500
NRH100	100	600
NRH100	100	700
NRH100	100	800
NRH100	100	900
NRH100	100	1000
NRH100	100	1200
NRH100	100	1400
NRH100	100	1600
NRH100	100	1800
NRH100	100	2000
NRH100	100	2200
NRH100	100	2400
NRH100	100	2600
NRH100	100	2800
NRH100	100	3000
NRH100	100	3200
NRH100	100	3400
NRH100	100	3600
NRH100	100	3800
NRH100	100	4000
NRH100	100	4200
NRH100	100	4400
NRH100	100	4600
NRH100	100	4800
NRH100	100	5000
NRH100	100	5200
NRH100	100	5400
NRH100	100	5600
NRH100	100	5800
NRH100	100	6000
NRH100	100	6200
NRH100	100	6400
NRH100	100	6600
NRH100	100	6800
NRH100	100	7000
NRH100	100	7200
NRH100	100	7400
NRH100	100	7600
NRH100	100	7800
NRH100	100	8000
NRH100	100	8200
NRH100	100	8400
NRH100	100	8600
NRH100	100	8800
NRH100	100	9000
NRH100	100	9200
NRH100	100	9400
NRH100	100	9600
NRH100	100	9800
NRH100	100	10000



Example
NRH100-4-A2-z20-m3H-TP-P3-AM

Positioning

Reliability – Regardless of the mounting position

Our high-performance planetary gearboxes can be used in any mounting orientation. Whether your application requires a horizontal output (HI), vertical with upright facing output (VI) or vertical with downwards-facing output (V2) – the universal TP configuration covers any orientation.

For specific applications, including continuous operation together with high input speeds, we recommend the use of an additional air-vent plug (breather). This air-vent plug can be installed at any time – even as a retrofit on installed gearboxes.

In order to optimize gearbox performance, we recommend specifying the actual mounting position VI, V2 or HI, especially for ratios requiring a 3-stage gearbox.

Mounting positions

All positions

GÜDEL

Standard inputs

AM – Motor adaptability

Optional inputs

For special applications, in which the motor cannot be directly mounted on the gearbox, it is possible to fit the gearbox with an optional input shaft.

Example AC

Example AL

AL – Smooth primary shaft

AC – Keyway primary shaft

Order reference

Choose your appropriate motor interface

Code example

Motor flange diameter	Motor mounting diameter	Motor output shaft dimensions
R130 / d9	S110 / t3.5	d24 x L50
Flange diameter of plug hole or bracket [mm]	Flange diameter of motor housing [mm] Flange diameter of keyway [mm]	Shaft diameter [mm] Shaft length [mm]

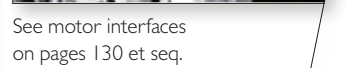

See motor interfaces on pages 130 et seq.

See general introduction about our inputs on pages 16 et seq.

See general introduction about our positioning on pages 20 et seq.

Choose your appropriate motor interface

Code example

Motor fixing diameter		Motor centring diameter		Motor output shaft dimensions						
R130	/	d9	-	S110	/	t3.5	-	d24	x	L50
R Pitch diameter of fixing holes or threads [mm]		Ød Diameter of fixing holes [mm]		S Centering diameter [mm]		t Depth of centering shoulder [mm]		d Diameter [mm]		L Length [mm]
		M Diameter of fixing threads [mm]								

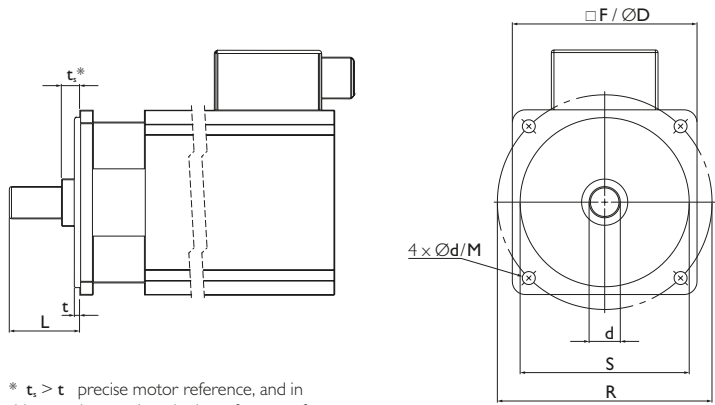

* $t_1 > t$ precise motor reference, and in this case change t by t_1 in the reference of motor flange.

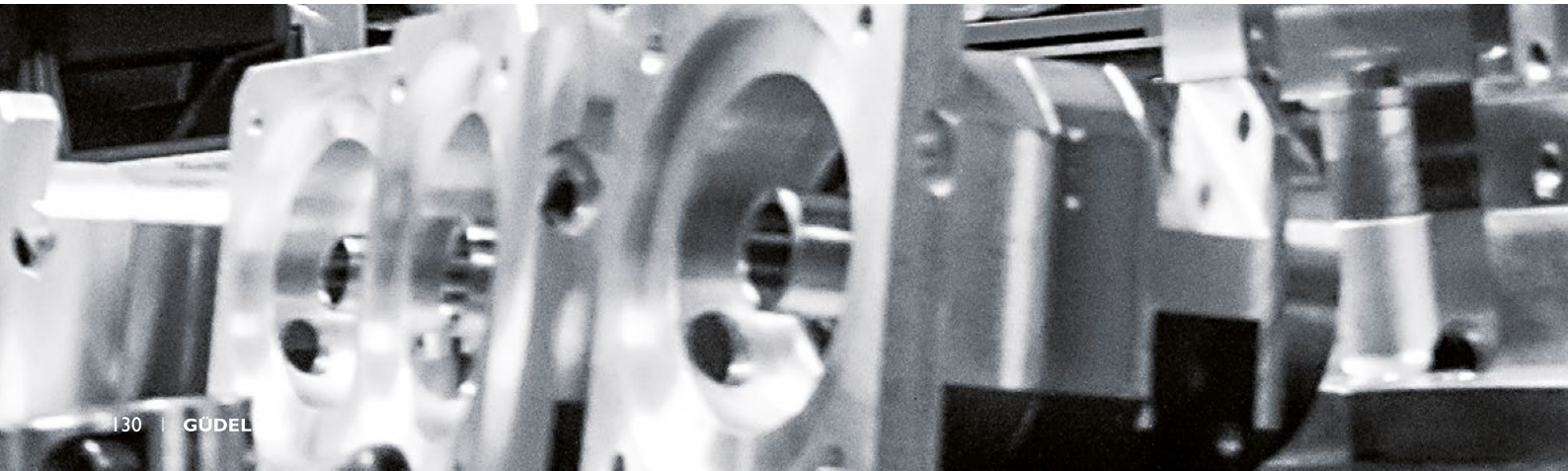

Calculate your planetary gearbox

This outline enables you to select your gearbox quickly. If you know which motor you will be using, you can create a preliminary design for your application.

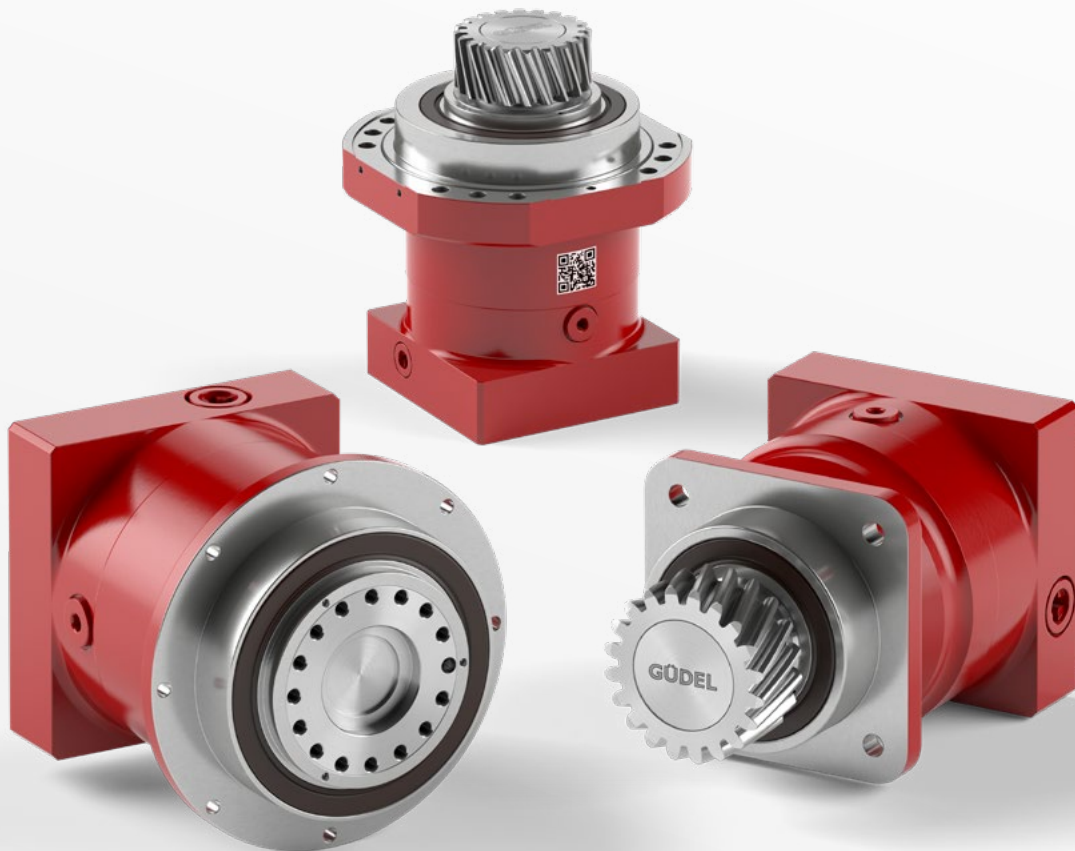

Quick selection

ED Duty cycle
 $T_{max\,mot}$ Max. acceleration motor torque
i Reduction ratio
 $T_{1n\,mot}$ Nominal motor torque

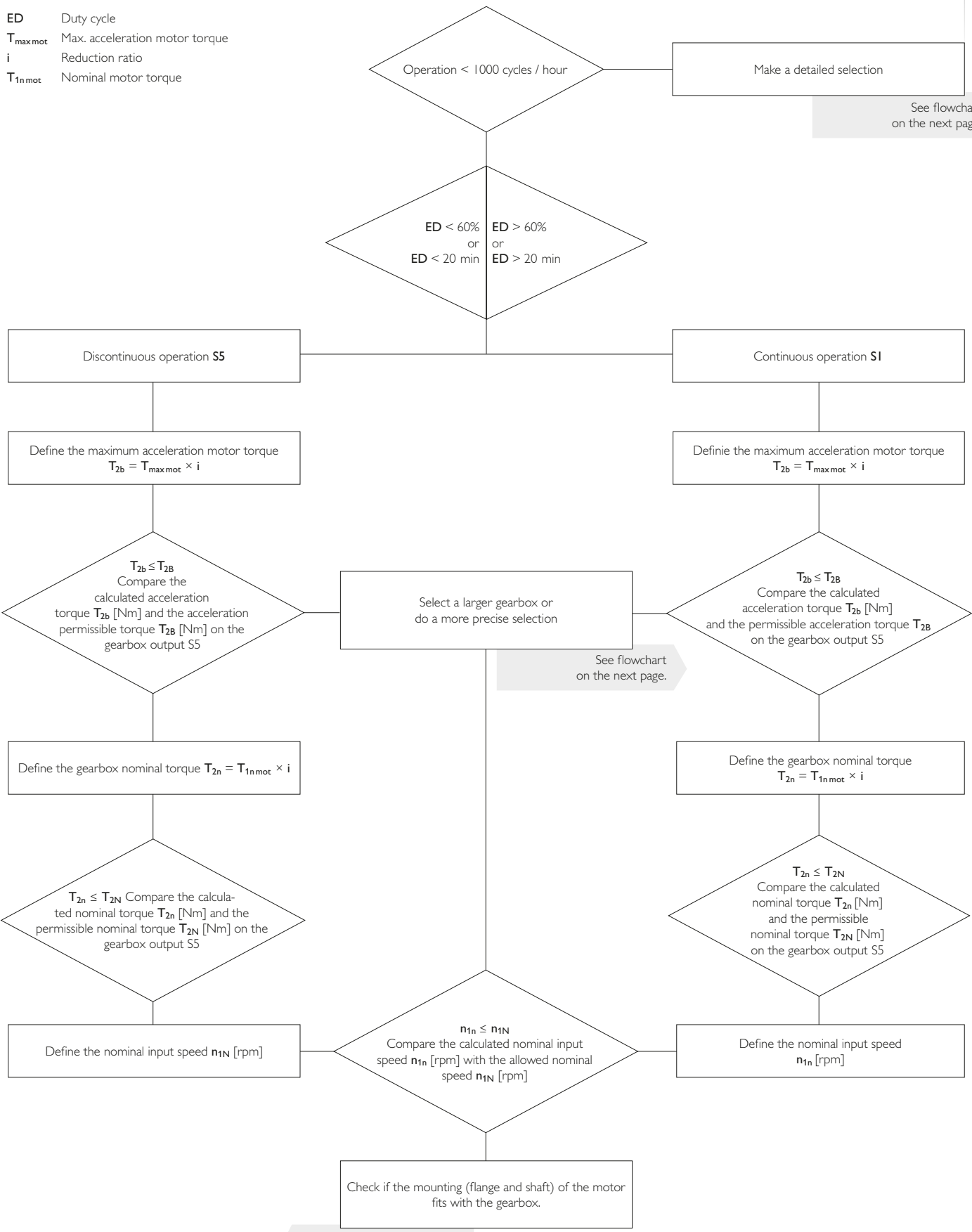

See flowchart on the next page.

See flowchart on the next page.

See motor interfaces on pages 130 et seq.

Detail selection

$$ED = (t_b + t_c + t_d) / (t_b + t_c + t_d + t_e) \times 100 \%$$

$$ED = t_b + t_c + t_d \text{ [min]}$$

$$Z_h = \frac{3600 \text{ [s/h]}}{(t_b + t_c + t_d + t_e)}$$

F depends on Z_h (see Board I)

T_{2b} under application

$$T_{2bfs} = T_{2b} \times f_s$$

n_{2max} under application

i depends on:

- n** Necessary output rotation speed (under application)
- Λ** Depending on inertia ratio, indicative value: $1 \leq \Lambda \leq 10$
 $n_{1max} = n_{2max} \times i$
 $n_{1max} = n_{1maxmot}$
- T** Depending on the output torque and the driving torque
 $T_{1b} = T_{2b} \times (1/i) \times (1/\eta)$
 $T_{1b} < T_{maxmot}$

T_{2not} under application

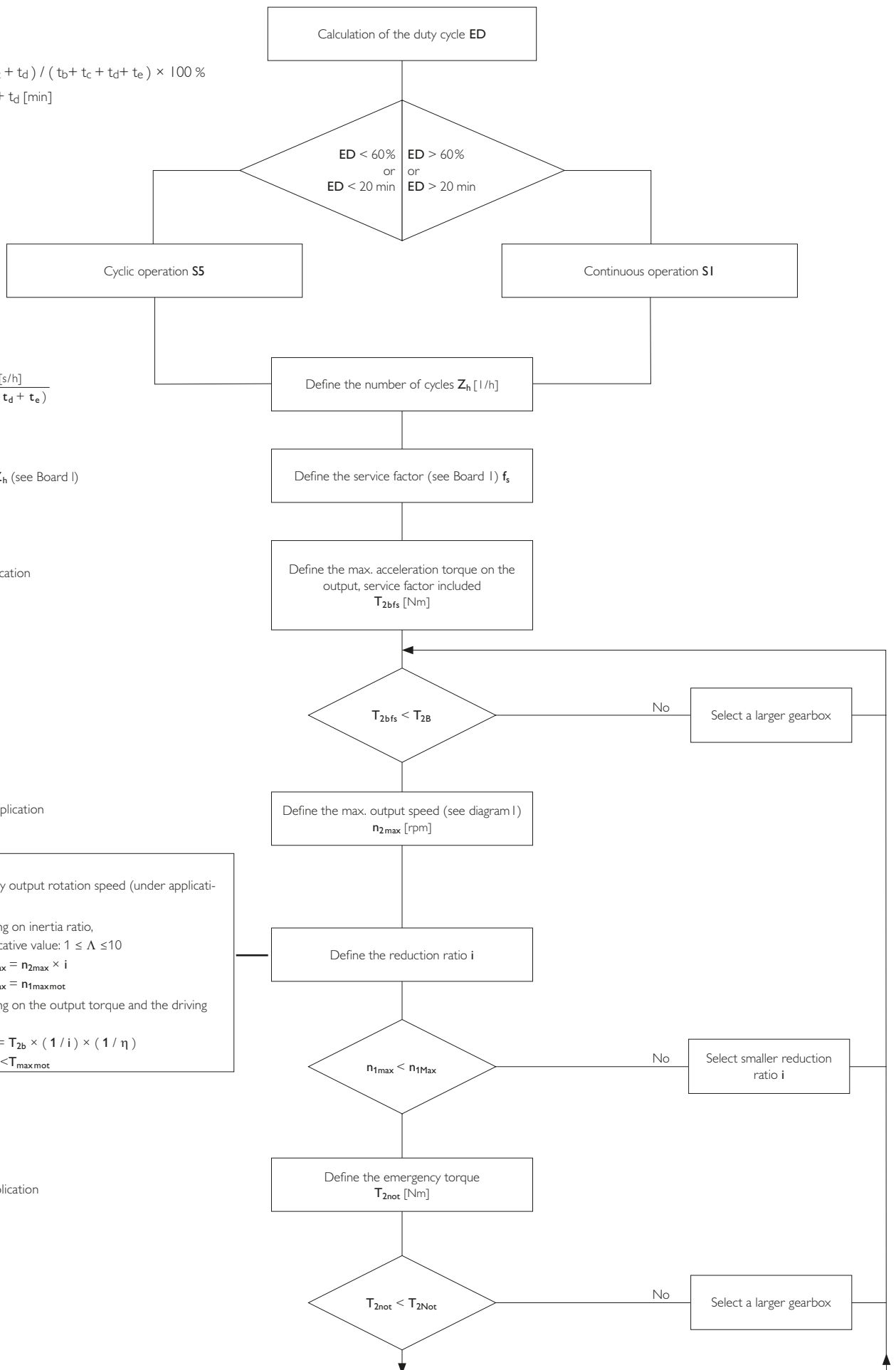

$$T_{2m} = 3 \sqrt{\frac{|n_{2b}| \times t_b \times |T_{2b}|^3 + \dots + |n_{2n}| \times t_n \times |T_{2n}|^3}{|n_{2b}| \times t_b + \dots + |n_{2n}| \times t_n}}$$

$$n_{2m} = \frac{|n_{2b}| \times t_b + \dots + |n_{2n}| \times t_n}{t_b + \dots + t_n}$$

including dwell

$$n_{1m} = n_{2m} \times i$$

$$D_{W.Mot} < D_{tightening\ hub}$$

The motor shaft should be inserted a good distance into the tightening hub.

The motor shaft should be inserted a good distance into the tightening hub without effort.

$$T_{2maxmot} = T_{1maxmot} \times i \times \eta$$

When the engine is under full load, the gear must not be damaged. In the case of damage, limit the motor current.

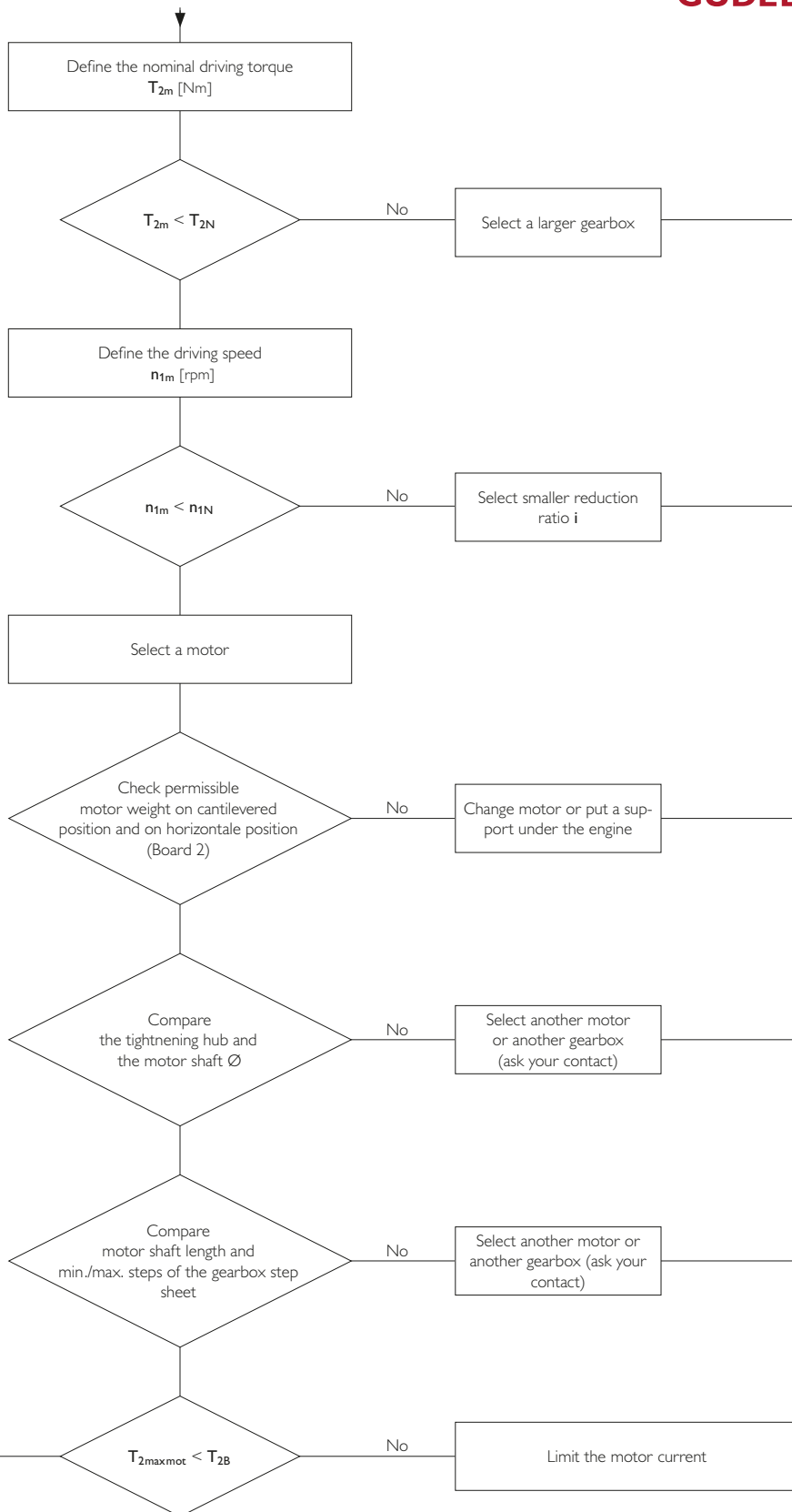
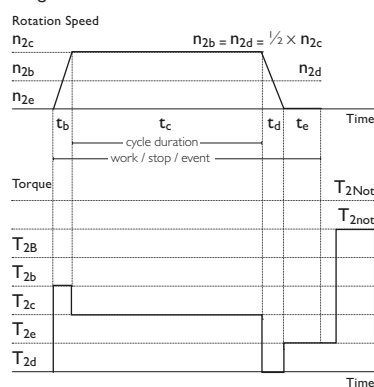

Diagram I



Board 1

Number of cycles p. h.	Z _h	[1/h]	1000	1500	2000	3000	4000	5000	6000	7000	8000	9000	10000
Shock factor	f _s	[-]	1	1.1	1.3	1.6	1.72	1.8	1.9	1.95	2	2.05	2.07

Board 2

Size	080	100	140	180	240
Max. motor weight	9.3	20	37	74	150

Calculate your ideal drive train

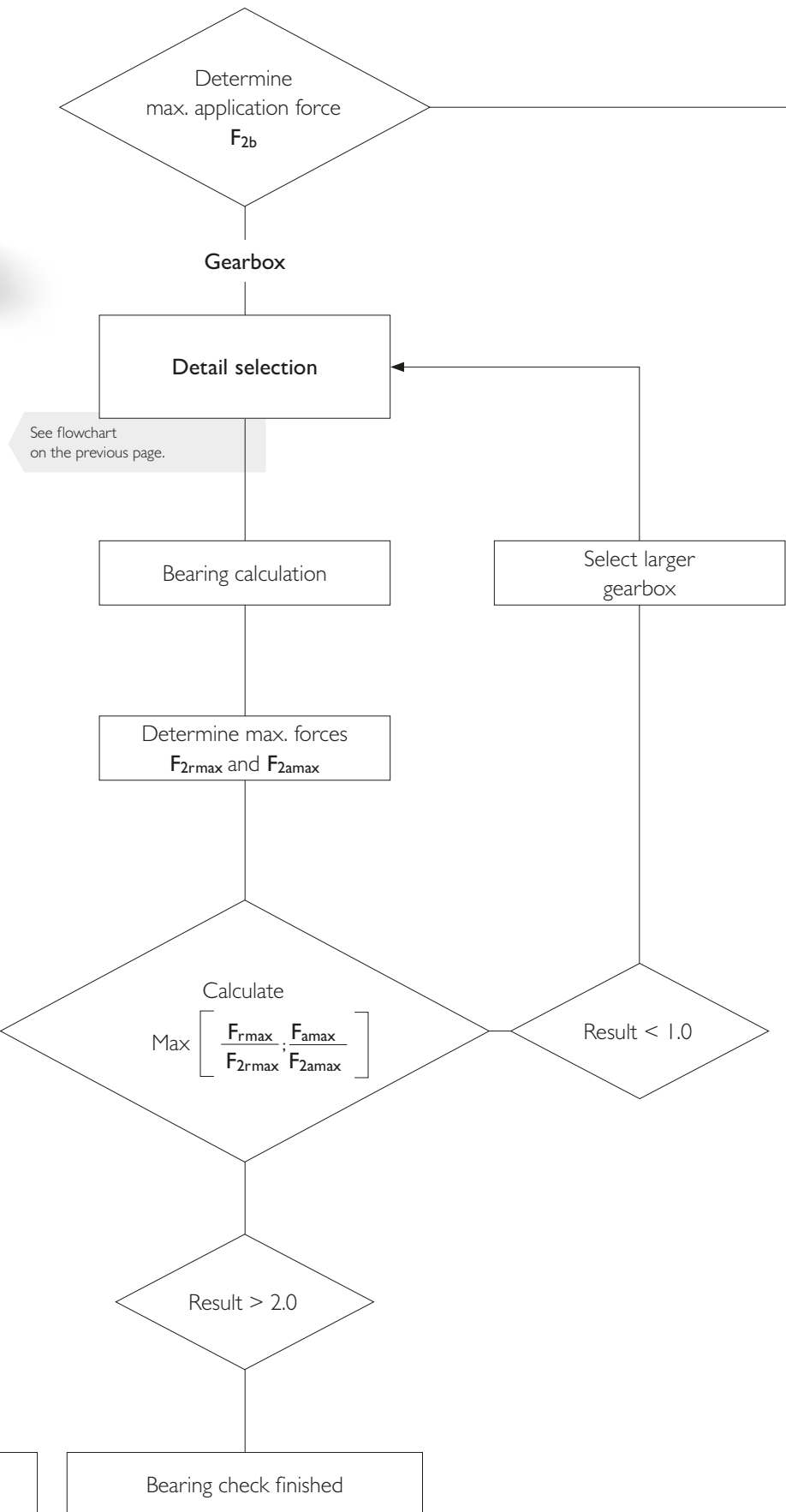

Function package selection

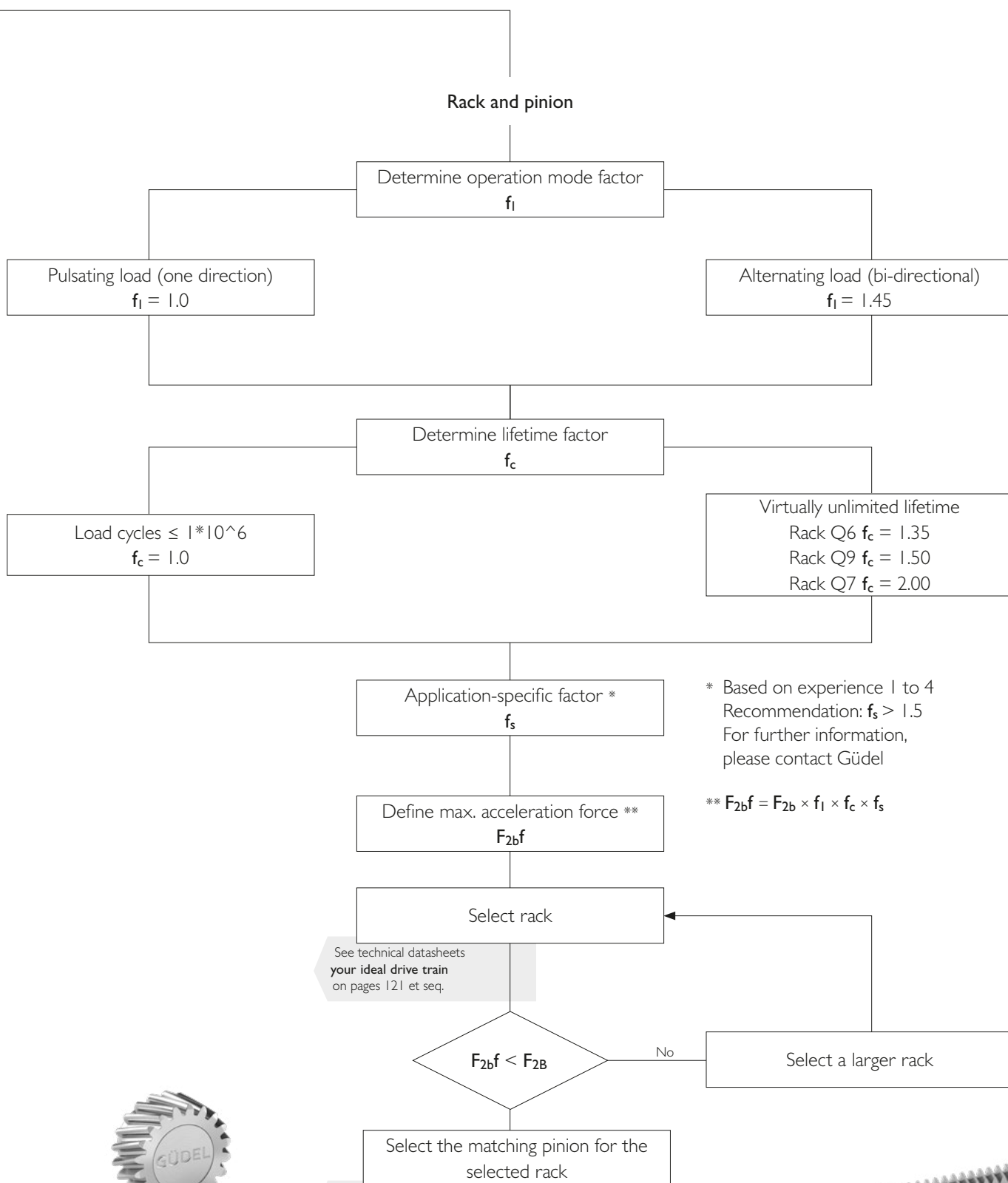

See technical datasheet
your ideal drive train
on page 120.

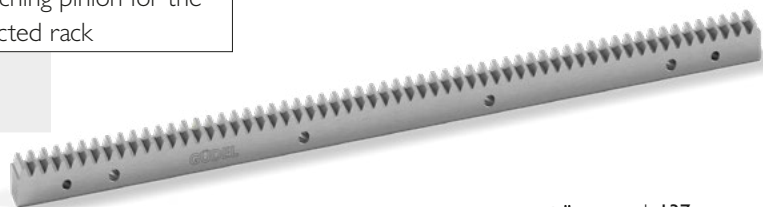



Güdel worldwide

GÜDEL

Contacts

Europe

Switzerland

Güdel Group AG (Headquarters)
Gaswerkstrasse 26
4900 Langenthal
Phone +41 62 916 9191
info@ch.gudel.com

Güdel AG
Gaswerkstrasse 26
4900 Langenthal
Phone +41 62 916 91 91
info@ch.gudel.com

Austria

Güdel GmbH
Schöneringer Strasse 48
4073 Wilhering
Phone +43 7226 206900
info@at.gudel.com

Netherlands

Güdel AG
Eertmansweg 30
7595 PA Weerselo
Phone +31 541 66 22 50
info@nl.gudel.com

Czech Republic

Güdel a.s.
Holandská 4
63900 Brno
Phone +420 519 323 431
info@gudel.cz

France

Güdel SAS
Tour de l'Europe 213
3 Bd de l'Europe
68100 Mulhouse
Phone +33 1 30091545
info@fr.gudel.com

Güdel Sumer SAS
Le Roqual
Zone industrielle
Carsac-Aillac
24200 Sarlat-la-Canéda
Phone +33 5 53 30 30 80
info@gudel-sumer.com

Germany

Güdel Germany GmbH
(German Headquarters)
Industriepark 107
74706 Osterburken
Phone +49 6291 6446 0
info@de.gudel.com

Güdel Germany GmbH (Altenstadt)
Carl-Benz-Strasse 5
63674 Altenstadt
Phone +49 6047 9639 0
info@de.gudel.com

Güdel Germany GmbH (Nördlingen)
Industriestrasse 8
86720 Nördlingen
Phone +49 9081 2974 0
info@de.gudel.com

Güdel Germany GmbH (Ainring)
Gewerbestrasse 4a
83404 Ainring
Phone +49 8654 4888 0
info.gudel-controls@de.gudel.com

Güdel Intralogistics GmbH
Gewerbegebiet Salzhub 11
83737 Irschenberg
Phone +49 8062 7075 0
intralogistics@de.gudel.com

Italy

Güdel S.r.l.
Via per Cernusco, 7
20060 Bussero (Mi)
Phone +39 02 9217021
info@it.gudel.com

Poland

Güdel Sp. z o.o.
ul. Legionów 26/28
43-300 Bielsko - Biala
Phone +48 33 819 01 25
info@pl.gudel.com

Russia

Güdel AG
Yubileynaya 40
Office 1902
445057 Togliatti
Phone +7 8482 775444
info@ru.gudel.com



 **Spain**

Güdel AG
C/Industria 60, Local 7
08025 Barcelona
Phone +34 93 476 03 80
info@es.gudel.com

 **United Kingdom**

Güdel Lineartec (U.K.) Ltd.
Unit 5 Wickmans Drive
Banner Lane
CV4 9XA Coventry, West Midlands
Phone +44 24 7669 5444
info@uk.gudel.com

Americas

 **Brazil**

Güdel Lineartec
Comércio de Automação Ltda.
Rua Américo Brasiliense
n° 2170, cj. 506
Chácara Santo Antonio
São Paulo, CEP 04715 - 005
Phone +41 62 916 9191
info@ch.gudel.com

 **Mexico**

Güdel TSC S.A. de C.V.
Gustavo M. Garcia 308
Col. Buenos Aires
Monterrey, N.L. 64800
Phone +52 81 8374-2500
info@mx.gudel.com

 **USA**

Güdel Inc.
4881 Runway Blvd.
Ann Arbor, MI 48108
Phone +1 734 214 0000
info@us.gudel.com

Asia Pacific

 **China**

Güdel International Trading Co. Ltd.
Block A, 8 Floor, C2 BLDG
No. 1599 New Jin Qiao Road
Pudong
Shanghai 201206
Phone +86 21 5055 0012
info@cn.gudel.com

 **India**

Güdel India Pvt. Ltd.
Gat no. 458-459
Mauje Kasar Amboli
Pirangut, Tal.Mulshi
Pune 412 111
Phone +91 20 67910200
info@in.gudel.com

 **South Korea**

Güdel Lineartec Inc.
11-22 Songdo-dong
Yeonsu-Ku
Post no. 406-840
Incheon City
Phone +82 32 858 0541
info@kr.gudel.com

 **Taiwan**

Güdel Lineartec Co. Ltd.
No. 99, An-Chai 8th St.
Hsin-Chu Industrial Park
30373 Hu-Ko, Hsin-Chu
Phone +88 635 97 8808
info@tw.gudel.com

 **Thailand**

Güdel Lineartec Co. Ltd.
19/28 Private Ville Hua Mak Road
Hua Mak Bang Kapi
Bangkok 10240
Phone +66 2 374 0709
info@th.gudel.com



© Güdel AG

We have taken the greatest care in compiling this catalog with specifications and technical information. Please understand that we accept no liability for misprints, technical changes, or consequential damage in relation to the published information. The catalog is purely for information purposes, so the illustrations and information in no way represent guaranteed properties. The text, photos, drawings, and any other display formats in this catalog are intellectual property of Güdel AG. Please note that any duplication, editing, translation, saving, or any other subsequent use of the catalog or its components in print or electronically may only be carried out with the previous, express consent of Güdel AG. Güdel AG reserves the right to modify the provided information at any time in order to always be able to present you with the most up-to-date version of our catalog and products.



Güdel AG
Gaswerkstrasse 26
4900 Langenthal
Switzerland
Phone +41 62 916 91 91
info@ch.gudel.com
gudel.com